

Final Report

Nathan McGraw

Structural Option

Faculty Advisor: Dr. Richard Behr

April 4th, 2011

Inova Fairfax Hospital | South Patient Tower

Falls Church, VA

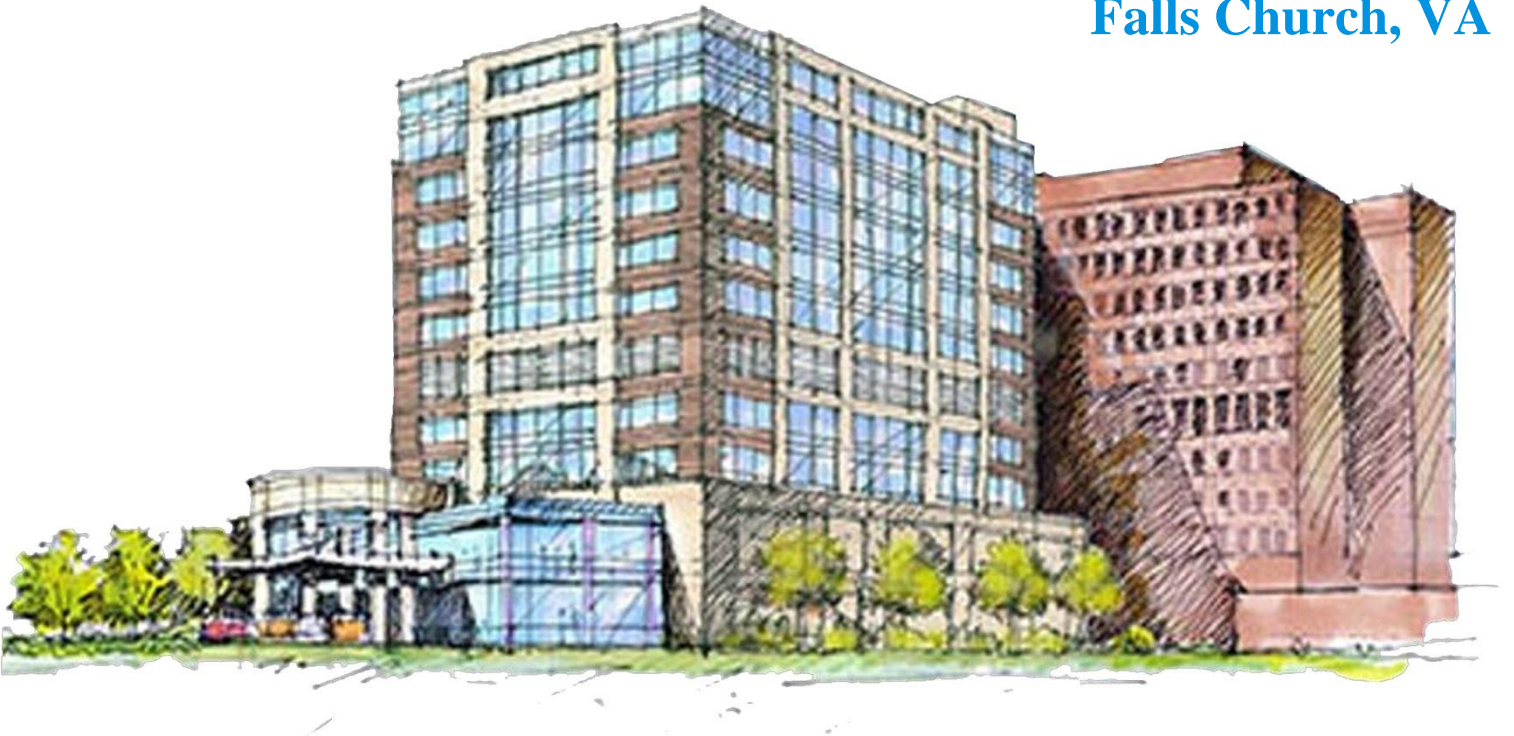



Hospital Patient Tower

Eastern United States

Nathan McGraw | Structural Option

General Information

Function:	Hospital/Patient Tower
Size:	236,000 SF
Height:	175' (12 stories above grade + 1 story below)
Construction:	Summer 2010 - Fall 2012
Construction Cost:	\$76 million
Delivery Method:	Design-Bid-Build

Project Team

Owner:	Not Released
General Contractor:	Turner Construction
Architect:	Wilmot/Sanz Architects
Structural:	Cagley & Associates
MEP:	RMF Engineering, INC.
Civil Engineer:	Dewberry & Davis LLC



MEP SYSTEMS

Mechanical:

- Four 50,000 CFM air handling units
- Three hot water heat exchangers
- Constant air volume (CAV) units distribute the air

Electrical:

- Two main feeds enter at 34.5 kV
- Two 5,000 kVA transformers feed a double-ended main substation
- Two parallel 2 MW backup generators
- Mechanical and lighting loads are fed at 480/277, receptacle and other loads at 208/120

Lighting:

- Lighting fixtures use 277 V
- Combination of linear T8's and compact fluorescents
- Facade consists of LED fixtures

ARCHITECTURE

- Facade largely composed of a smooth finished concrete panel and a thin brick faced concrete panel with an aluminum glass curtain wall system
- First two levels are composed entirely of the aluminum curtain wall system with a large two-story rotunda
- 174 all-private intensive-care and medical/surgical patient rooms

SUSTAINABILITY

- Native plants, water cisterns and a green roof surround the building
- Achieved LEED Silver Certification
- Use of low-VOC paints, building materials and furniture within the patient rooms
- Low flow plumbing fixtures and sensors

CONSTRUCTION

- Due to the connection with the existing part of the hospital, construction must not cause any delays with the existing structure
- Means of weather proofing the connected areas
- Coordination between the construction crews and the hospital staff

STRUCTURAL

- Foundation consists of auger-cast piles with pile caps
- Two-way flat slab with column drop panels comprise the floor system
- Shear walls and moment frames make up the lateral force resisting system
- Pre-engineered aluminum helicopter pad resides on the 11th floor roof

<http://www.engr.psu.edu/ae/thesis/portfolios/2012/NJM5071>

Table of Contents

Executive Summary:	4
Acknowledgements	5
Building Introduction:	6
Existing Structural Overview:	8
Foundations:	8
Floor Systems:.....	9
Framing System:.....	10
Lateral Systems:	10
Roof System:	13
Design Codes:.....	14
Thesis Codes and References:.....	14
Materials Used:	15
Gravity Loads:	17
Dead and Live Loads:	17
Snow Loads:	19
Lateral Loads:	20
Wind Loads:	20
Seismic Loads:	28
Problem Statement:	30
Problem Solution:	32
Breadth Topics:	33
MAE Coursework:	34
Structural Depth	35
Gravity Redesign:	35
Alterations to Structure:	39
California Site Overview:.....	40
Fixed Base Structure:	57
Base Isolated Structure:	59
Construction Management Breadth	68

Mechanical/Building Enclosure Breadth.....	73
Conclusion.....	80
References	81
Appendices	82
Appendix A: Typical Plans	82
Appendix B: Wind Load Calculations	86
Appendix C: Seismic Load Calculations Existing Structure: Falls Church, VA	99
Appendix D: Gravity Redesign Calculations	110
Appendix E: Fixed Base Iterations.....	124
Appendix F: Base Isolator Design Calculations	125
Appendix G: Earthquake Scaling for Time History Analysis	138
Appendix H: Construction Management Breadth	147
Appendix I: Mechanical/Building Enclosure Breadth.....	155

Executive Summary:

The South Patient Tower is a new, 236,000 square foot hospital/patient tower part of the Inova Fairfax Hospital system located in Falls Church, Virginia. The construction costs reach an estimated value of roughly \$76 million and the patient tower has several architectural features that separate this structure from a normal patient tower. The façade is composed largely of a curtain wall system with a precast concrete panel assembly to match the surrounding architecture. The main gravity system consists of a two-way flat slab with drop panels resting on cast-in-place concrete columns. The lateral system consists of shear walls and moment frames scattered throughout the building to resist the shears in both the orthogonal directions.

The bulk of this report is comprised of two redesigns of the original structure. Because the existing structure adequately resisted the shear forces applied from both wind and seismic forces, the choice was made to move the structure to a new location. However, before the relocation, the existing structure was redesigned using a one-way concrete slab in place of the two-way flat concrete slab in order to increase the overall stiffness of the structure and decrease torsional effects. The weight decreased slightly due to the redesign, but minimal effects were seen in terms of the base shear values.

A scenario was then created in which the University of California's branch campus located near Sacramento, California (specifically Davis, CA) requested the construction of a similar patient tower to serve the campus. A geotechnical report was obtained for the new site resulting in similar design parameters as the existing site location. The one-way slab system (CA – Base Model) was then used to calculate new wind and seismic forces and account for torsional irregularities.

Finally, two separate structures were designed to meet similar performance requirements. A high performance seismic building was investigated throughout this report. The two designs were intended to meet S-1 "Immediate Occupancy" criteria set forth in ASCE's "Seismic Rehabilitation of Existing Buildings" (ASCE 41-06). The first structure designed modifies the CA – Base Model to meet the requirements for S-1. This design relied heavily on larger members, including thicker shear walls and deeper concrete moment frames. The second model constructed included the use of base isolators to achieve the high performance requirement while keeping the structural member sizes to a minimum. This was achieved by modifying the CA – Base Model and using nonlinear properties to accurately model the isolators in ETABS. Master's level coursework was integrated throughout the report, including the computer modeling of structures (AE 597A), earthquake resistant design (AE 538) and building enclosures (AE 542).

To fully compare the structures designed, a construction management breadth was undertaken which calculated the estimated costs and schedule impacts of requiring a higher seismic performance guideline. Quantities were used to calculate take-offs and daily output values for the structural components to determine the durations for activities. The existing schedule was modified to account for the CA – Fixed Model and the CA – Base Isolation Model. This analysis found that the CA – Fixed Model was roughly \$700,000 less than CA – Base Isolated Model and about a month less in overall duration.

Finally, with the relocation of the building to California, the use of a lower U-value glazing system was analyzed to improve the thermal performance of the existing façade assembly in Sacramento, CA. Using H.A.M. Toolbox and TRACE, the existing façade was analyzed for condensation issues in CA. Utilizing TRACE, the main hospital was modeled with a typical patient room as the main focus point. Although the alternate glass system costs more up front, the lower U-value system allows for annual savings to compensate for the additional immediate costs.

Acknowledgements

I would like to extend my gratitude to the following people and companies for their support in completing this research report:

Turner Construction, for providing the project and the owner permission form. For their swift responses to questions and their willingness to assist, I would like to specifically thank:

Tessa Teodoro
James Kelleher
Joseph Kranz

The entire AE student body and specifically the following friends, I enjoyed their company every waking minute in thesis lab:

David Tran
Jake Wiest
Raffi Kayat
Joshua Progar
T.J. Kleinosky
Chris D.
Britt Kern
Mike Morder
Daniel Wiggins

The entire AE faculty, specifically:

Dr. Richard Behr
Professor M. Kevin Parfitt
Professor Robert Holland

I would also like to thank my parents, John and Shirley, and my close friends back home for their relentless support during this whole process.

Building Introduction:

As an early phase in the Inova Fairfax Hospital Campus Development Plan, the South Patient Tower will be connected to the existing patient tower (see Figure 1) at all levels above grade including the penthouse. Construction started in the Summer of 2010 and is expected to be completed by Fall 2012 with an overall project cost of around \$76 million. Standing at 175 ft, the 236,000 ft² concrete structure consists of 12 stories above grade (excluding the penthouse) with an additional story below grade. A system of auger-cast piles and pile caps are used to support the structure with a soil bearing pressure of 3000 psf.

Along with the physical connection, the architecture of the South Patient Tower shares some similarities with the surrounding campus/hospital buildings. Wilmot/Sanz Architects designed the South Patient Tower as a continuation of the main architectural features of the existing patient tower building while at the same time displaying Inova's commitment to sustainable and functional buildings. Consisting of 174 all-private intensive-care and medical/surgical patient rooms, the floor plans are situated so that the various intensive-care unit specialties correspond to the same level as that of the existing main hospital. In order to meet the patient's specialized needs, workstations will be placed outside of the patient's rooms to maintain privacy while being able to monitor the patients at the same time.

The façade is largely composed of a smooth finished precast concrete panel as well as a precast concrete panel with a thin brick face (see Figure 2). To add more architectural detail, thin brick soldier courses are used at every story level, starting with the 4th floor and continuing up the building to the 11th floor. The only tangent from the typical architectural pattern occurs on the 5th floor (main mechanical floor) where architectural louvers are used to allow air to exit the building. The first two levels are composed entirely of an aluminum curtain wall system which is also used for the majority of the building's windows. The two main architectural features that stand out along the ground floor of the building are the large two-story rotunda and the canopy covering the main entrance which is constructed from 4 custom steel columns. The South Patient Tower is attempting to achieve LEED Silver Certification by including numerous sustainable design features (see Figure 3). Inside the patient rooms,



Figure 1:
Aerial map from Bing.com showing the location of the building site



Figure 2:
Exterior rendering showing the circular entrance and precast concrete façade (Provided by Turner Construction)

the use of low-VOC paints, building materials and furniture will lead to higher indoor air quality. Also, the use of low flow plumbing fixtures and sensors will reduce water consumption by up to 30%. Outside of the building, native drought resistant plants will surround the building. From the patient rooms, guests will be able to see the green roof and the water cisterns used to capture rain water.

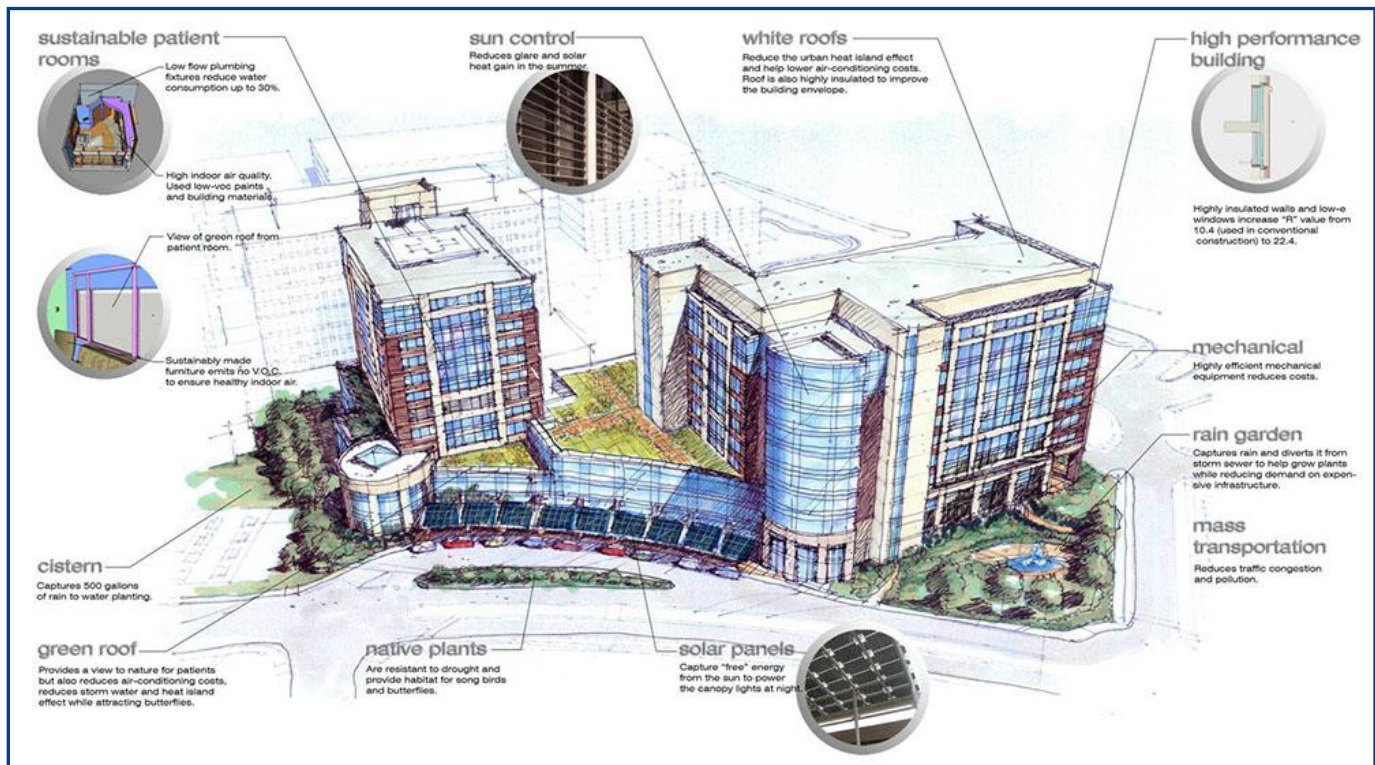

Figure 3:
Sustainability features (rendering provided by Wilmot/Sanz Architects)

Existing Structural Overview:

Foundations:

Schnabel Engineering North performed the geotechnical studies for the South Patient Tower (SPT) and provided the report in which they explain the site and below-grade conditions. The structural engineers of Cagley & Associates designed the foundation for an undisturbed soil net allowable bearing pressure of 3000 psf. Also given in the geotechnical report are lateral equivalent fluid pressures which are 60 psf/ft of depth for both the braced walls and cantilevered retaining walls. The sliding resistance (friction factor) was found to be 0.30.

In light of the soil conditions, the SPT utilizes a foundation with a system of 16 in. diameter auger-cast piles and pile caps on top of a slab on grade (see Figure 4). Due to higher stresses around the staircase and elevator pit, a large pile cap is situated around each of these areas to help alleviate the stresses on the slab (see Figure 5). The number of piles per pile cap varies throughout the foundation with the most common being 9 and 11.

Along with the 5 in. slab on grade, grade beams connect the piles within the foundation footprint. Along the perimeter of the foundation, the SPT makes use of spread and strip footings (see Figure 6). Since the foundation does not cover the entire area of the ground floor, some areas consist of piles and pile caps directly underneath the ground floor slab to support the main entrance and lobby space.

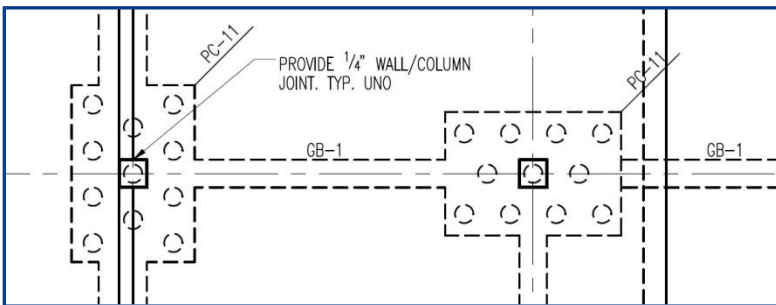

Figure 4:
Typical pile and pile cap (Provided by Turner Construction)

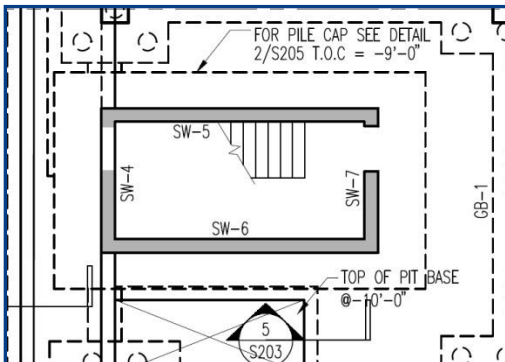

Figure 5:
Pile cap constructed around staircase (Provided by Turner Construction)

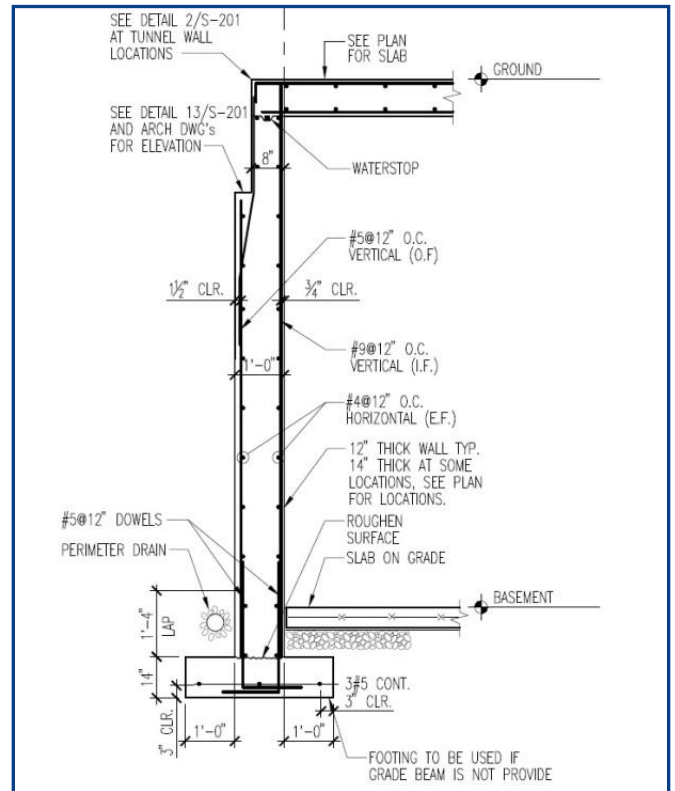

Figure 6:
Spread footing with basement wall (Provided by Turner Construction)

Floor Systems:

The elevated floors of the South Patient Tower are comprised of a 9 ½ in. two-way flat concrete slab. A drop panel is located at every column location in order to prevent punching shear as well as to increase the thickness of the slab to help with the moment carrying capacity of the slab near the columns. The typical size for the drop panel is 10 ft x10 ft x 6 in.

For the ground floor through the 4th floor, 5000 psi concrete is used for construction of the two-way slab while the upper floors use a 4000 psi concrete. The one exception to the 9 ½ in. slab is the mechanical floor (5th floor). Because of the higher load imposed by the mechanical equipment over the entire floor, the slab was designed accordingly and increased to a 10 ½ in. depth.

Reinforcement for the two-way slab system is comprised of both top and bottom steel. The typical bottom reinforcement consists of #5@12 in. o.c. each way (see Figures 7 and 8 for reinforcement details). Additional bottom reinforcement is listed on the drawings wherever needed as well as top reinforcement, which is located in areas of negative moments (mainly around the columns and between column lines depending on which direction the frame of interest is going). With a fairly simple column layout, the two-way slab system has a span of 29 ft in both directions for the most part.

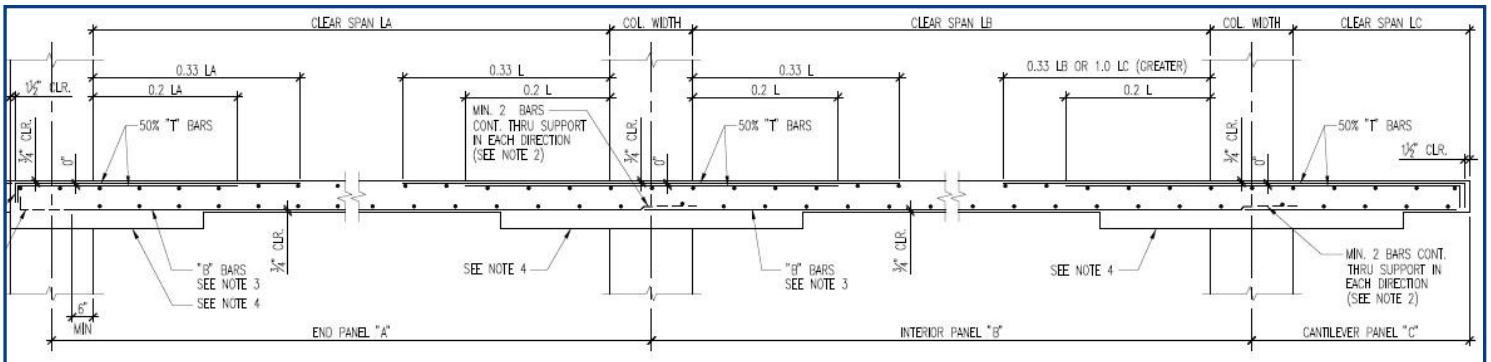

Figure 7:
Typical column strip reinforcement and placement (Provided by Turner Construction)

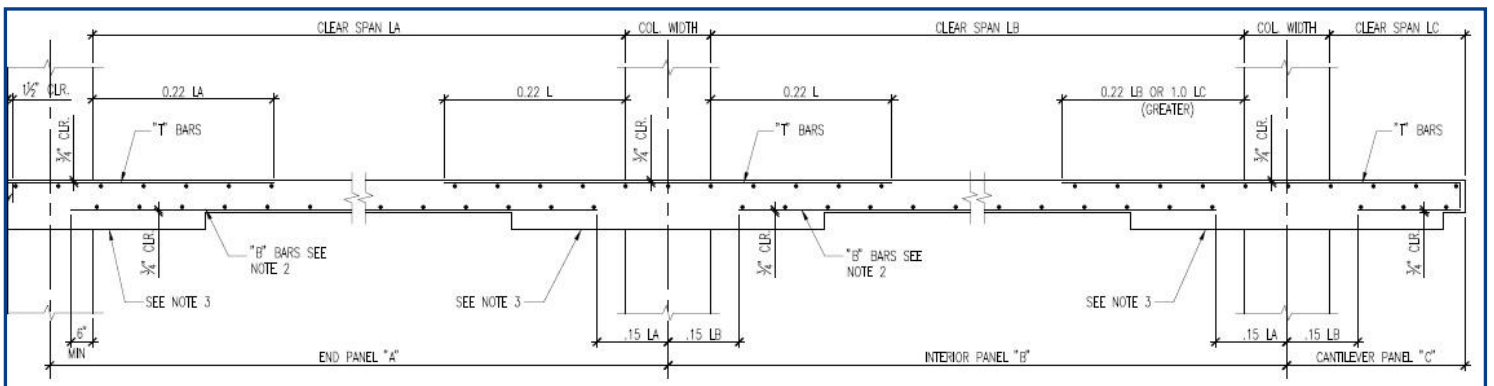

Figure 8:
Typical middle strip reinforcement and placement (Provided by Turner Construction)

Framing System:

As mentioned in the previous section, the columns follow a pretty regular pattern with a few exceptions. Typically the bay sizes are 29 ft x 29 ft with drop panels at every location. There are no interior beams, but there are a few beams along the perimeter of the building towards the south end of the structure and near the connection to the existing hospital.

The columns are all cast-in-place concrete with the largest column being 30 in. x 30 in. at the basement level. The typical column size is 24 in. x 24 in. and 12 in. x 18 in. (rotated as required to fit the wall thickness). Because of the higher loads located in the columns towards the lower portions of the building, 7000 psi concrete is utilized up to the 5th floor level with the rest of the upper floor columns being 5000 psi concrete. Consisting of mainly #11 reinforcement bars with #4 stirrups, the maximum number of longitudinal reinforcement bars within a column is 20, with the typical number being 4.

Lateral Systems:

Shear walls and ordinary moment resisting frames make up the main lateral force resisting system in the South Patient Tower and are situated throughout the building to best resist the lateral forces in the building. Seven different walls make up the shear wall system which surrounds both the main staircase and the main elevator while the moment frames are situated near the connection to the existing portion of the hospital and at the far end of the structure (see Figure 9 located on the next page). The shear walls are 12 in. thick and are composed of 5000 psi cast-in-place concrete. Most span from the basement level to the main roof line, but the northern core around the elevator shaft extends up the entire 175 ft height to the top of the penthouse level.

All of the shear walls are connected to the foundation with dowels to properly allow the loads to travel through the walls down to the foundation. The moment frames are mainly situated in the Y-Direction. After performing the analysis using ETABS, the displacements found in the Y-Direction were significantly smaller than the X-Direction. Due to the connection with the existing structure, the displacements in the Y-Direction are limited. This explains the need for most of the moment frames in that direction as well as the larger shear walls located near the connection point. Because most of the rigidity falls near the existing structure, the far end located furthest from the connection point could be of concern when dealing with displacements due to the lack of a lateral system in the X-Direction. Detailed elevations of the shear wall can be seen in Figure 10 depicting the various openings located in shear walls in both the X and Y direction.

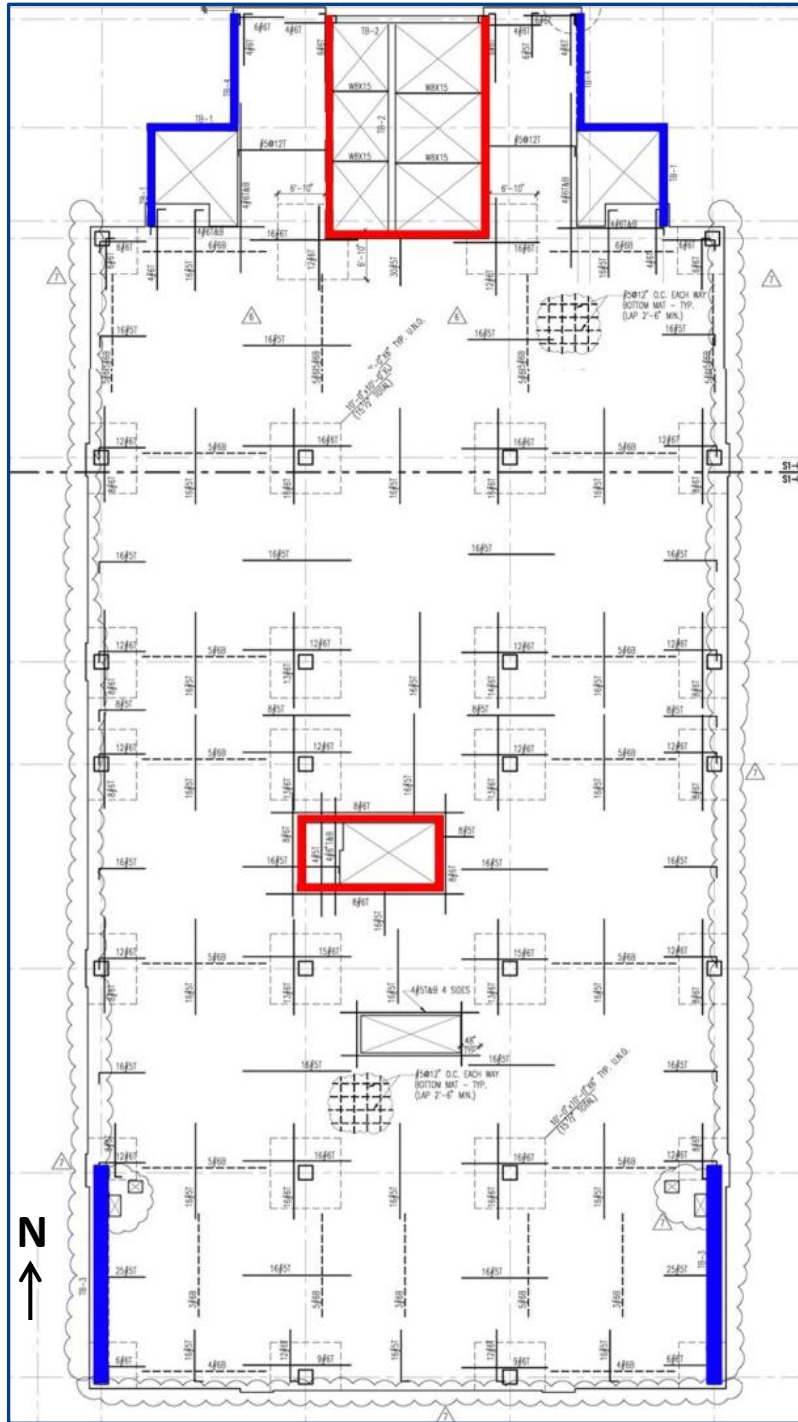

Figure 9:
 Typical floor plan depicting the shear walls (shaded in red) and the moment frames (shaded in blue)
 Adapted from drawing S1-04-1 and S1-04-2 (Provided by Turner Construction)

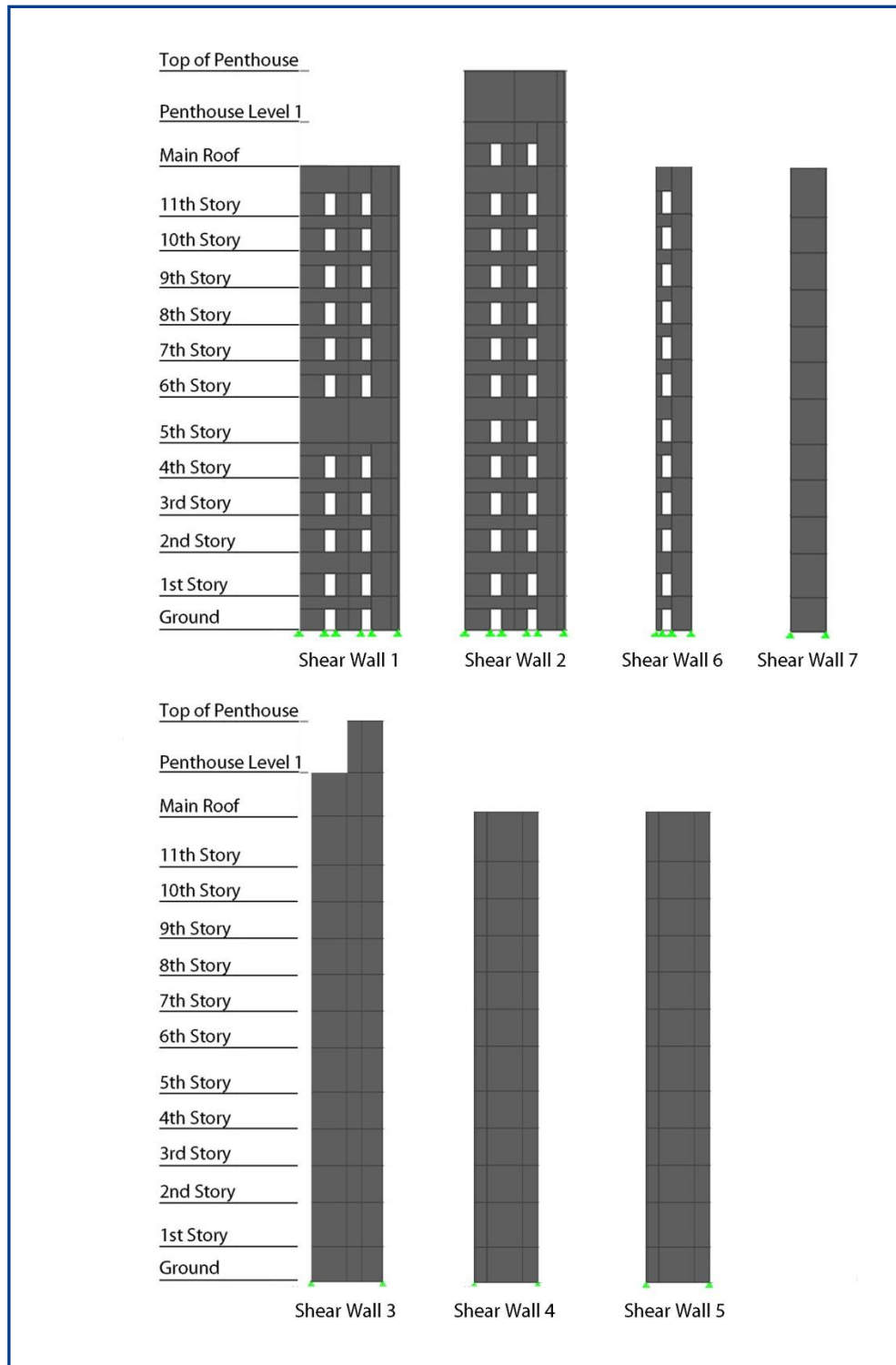

Figure 10: Shear wall elevations with the upper half being the walls located in the Y-Direction and the lower half in the X-Direction

Roof System:

In general, there are three different main roof levels (see Figure 11). The roofing system on the 11th floor is comprised mainly of Polyvinyl-Chloride (PVC) roofing situated on top of composite polyisocyanurate board insulation. This system rests on top of a concrete slab with varying thickness.

Highlighting the 11th floor roof is the pre-engineered aluminum helicopter landing system. Supporting the landing platform is a system of structural steel columns with vibration isolators.

The main design features of the lower roof level (2nd floor) consist of a vegetated roof system, accent vegetation and concrete roof pavers. Also, on the lower roof a hexagonal skylight covers the circular rotunda (see Figure 12). The slab thickness for the lower roofs (excluding the green roof) varies but is mainly 9 ½ in., while the main roof, which supports higher loads from the mechanical penthouse, is 12 in. thick.

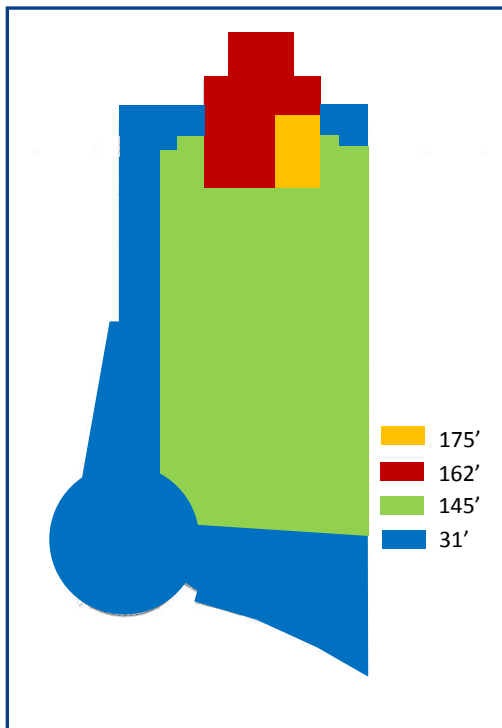

Figure 11:
Showing various SPT roof heights in relation to the ground height of 0'-0"

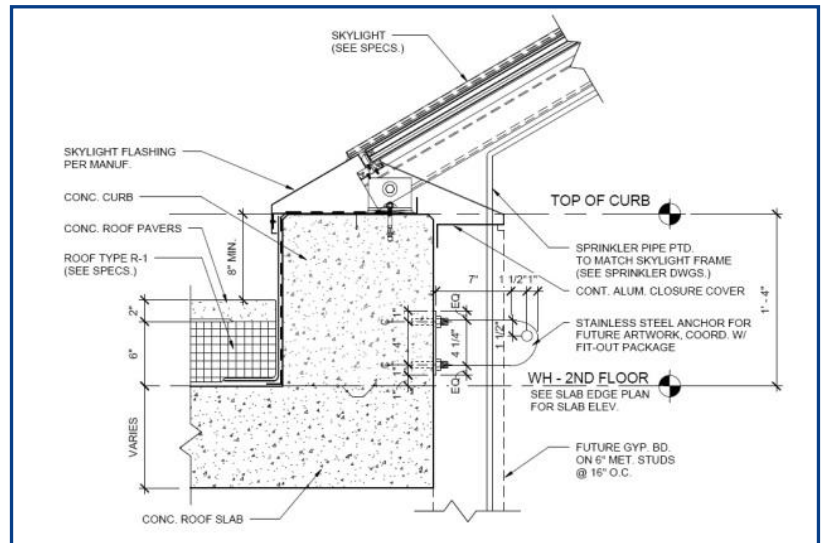

Figure 12:
Roof and skylight detail (Provided by Turner Construction)

Design Codes:

According to Sheet S0-01, the original building was designed to comply with the following codes/standards:

- 2006 International Building Code (IBC 2006)
- 2006 Virginia Uniform Statewide Building Code (Supplement to 2006 IBC)
- Minimum Design Loads for Building and Other Structures (ASCE7-05)
- Building Code Requirements for Structural Concrete (ACI 318-05)
- American Concrete Institute Manual of Concrete Practice – Parts 1 through 5 (ACI)
- Manual of Standard Practice (Concrete Reinforcing Steel Institute)
- Manual of Steel Construction – Allowable Stress Design 9th Edition (American Institute of Steel Construction - AISC)
- Manual of Steel Construction, Volume II, Connections (ASD 9th Edition/LRFD 1st Edition – AISC)
- Detailing for Steel Construction (AISC)
- Structural Welding Code ANSI/DWS D1.1 (American Welding Society – AWS)
- Design Manual for Floor Decks and Roof Decks (Steel Deck Institute – SDI)
- Standard Specifications for Structural Concrete (ACI 301)

Thesis Codes and References:

- 2009 International Building Code
- ASCE 7-05
- ACI 318-08
- AISC Steel Manual - 14th Edition (2010)

Materials Used:

The various kinds of materials and standards used for the construction of the South Patient Tower are listed below in Figures 13a and 13b. All information was derived from Sheet S0-01.

Concrete		
Usage	Strength (psi)	Weight
Piles	4000	Normal
Pile Caps	5000	Normal
Footings	3000	Normal
Grade Beams	3000	Normal
Foundation Walls	3000	Normal
Shear Walls	5000	Normal
Columns	5000/7000	Normal
Slabs-on-Grade	3500	Normal
Reinforced Slabs LG-L4	5000	Normal
Reinforced Beams LG-L4	5000	Normal
Reinforced Slabs L5-Roof	4000	Normal
Reinforced Beams L5-Roof	4000	Normal
Topping Slabs	3000	Lightweight
Concrete on Steel Deck	3000	Lightweight

Steel		
Type	Standard	Grade
Wide Flange Shapes and Tees	ASTM A992	50
Round Hollow Structural Shapes	ASTM A992	B ($F_y = 35$ ksi)
	ASTM 501	$F_y = 36$ ksi
Square or Rectangular Hollow Structural Shapes	ASTM A500	B ($F_y = 46$ ksi)
Other Structural Shapes and Plates	ASTM A36	N/A
High Strength Bolts	ASTM A325 N	N/A
Smooth and Threaded Rods	ASTM A572	N/A
Headed Shear Studs	ASTM A108	N/A
Welding Electrodes	AWS A5.1 or A5.5	E70xx
Galvanized Steel Floor Deck	ASTM A653 SS	33

Figure 13a:

Summary of materials used on the SPT project with design standards and strengths

Reinforcement	
Type	Standard
Deformed Reinforcing Bars	ASTM A615 (Grade 50)
Weldable Deformed Reinforcing Bars	ASTM A706
Welded Wire Fabric (WWF)	ASTM A185
Epoxy Coated Reinforcing Bars	ASTM A6775
Mechanical Connection Splices	DYIDAG, Lenton, or ACI 318 §12.14.3
Adhesive Reinforcing Bar Doweling Systems	ASTM A621

Miscellaneous	
Type	Standard/Value
Cement	ASTM C150 (Type I or II)
Blended Hydraulic Cement	ASTM C595
Aggregates	ASTM C33 (NW) ASTM C330 (LW)
Air Entraining Admixture	ASTM C260
Chemical Admixture	ASTM C494
Grout	ASTM C1107 ($F'_c = 5000$ psi)

Concrete Water Cementitious Ratio	
F'_c @ 28 Days (psi)	W/C (Max)
$F'_c \leq 3500$	0.55
$3500 < F'_c < 5000$	0.50
$5000 \leq F'_c$	0.45

Figure 13b:

Summary of materials used on the SPT project with design standards and strengths

Gravity Loads:

The dead, live and snow loads have all been calculated and compared to the loads listed on the structural drawings.

Dead and Live Loads:

The structural drawings list the superimposed dead loads used by the structural engineers for the design of the gravity members which are summarized in Figure 14.

Superimposed Dead Loads	
Description	Load
Floors	20 psf
Standard Roof	20 psf
Main Roof	20 psf

Figure 14:

Summary of superimposed dead loads

Following the confirmation of the superimposed dead loads, these loads along with the weights of the slabs, columns, shear walls, roofs, façade and the drop panels were used to calculate the overall weight of the entire structure. The exterior walls are made up of 5 ½ in. concrete with a ½ in. thin brick face. To simplify calculating the weight of this system, a 6 in. concrete panel was assumed to account for both elements. Figure 15 on the following page shows the overall weight of each floor as well as the complete weight of the entire structure which was found to be approximately 39,000 K.

A comparison of the live loads used in the SPT and Table 4-1 in ASCE 7-05 resulted in very little differences except when it came to the loads used for the offices as well as the patient floors (see Figure 16). The offices were all designed for 60 + 20 psf partition loading, which is 10 psf over the value given in Table 4-1. This could be due to the fact that offices are located on floors with patient rooms and corridors which both have a total live load of 80 psf. To be conservative, the project engineer probably just used 80 psf to be on the safe side. One other difference in live load occurred with the patient floor levels. According to ASCE, the minimum live load for hospital patient floors is 40 psf + partitions. However, the engineers for the SPT used 60 psf + partitions. A possible explanation for the increased load could be attributed to the future needs of individualized patients. Because certain patients may need different equipment, the exact load is uncertain. Therefore, the more conservative value of 60 psf was chosen. Calculations involving the patient floors will use 60 psf + 20 psf for partitions for this report and future reports.

Live loads for both the café and the roof were not given, but a live load of 80 psf was assumed for the café. Since the main roof utilizes a helicopter landing system, the specification for the system indicated a minimum live load of 100 psf and therefore will be used. Because the green roof will be accessible, a live load of 100 psf will be used for the lower vegetated roofs.

Weight Per Level		
Level	Area (ft ²)	Weight (kips)
Ground	25513	N/A
1st	25513	4393
2nd	11649	2418
3rd	17958	3902
4th	16571	3011
5th	16571	3285
6th	16571	3078
7th	16571	3011
8th	16571	3011
9th	16571	3011
10th	16571	3011
11th	16571	3066
Penthouse/Roof	16571	3831
		39026

Figure 15:
Distribution of weight per floor level

Live Loads			
Space	Design Live Load (psf)	ASCE 7-05 Live Load (psf)	Notes
Assembly Areas	100 (U)	100	N/A
Corridors	100	100 (first floor) ; 80 psf above	Based on both "Corridors" and "Hospitals" Section
Patient Floors	60 + 20	60 + 20	Based on "Hospitals - Operating Rooms, Laboratories"
Lobbies	100	100	N/A
Marquess and Canopies	75	75	N/A
Mechanical Rooms	150 (U)	N/A	N/A
Offices	60 + 20	50 + 20	Office Load + Partition Load
Stairs and Exitways	100 (U)	100	N/A
Café	N/A	80	N/A
Roof	N/A	100	Based on Future Helicopter Landing System

Figure 16:
Comparison of live loads

Snow Loads:

Following the procedure outlined in Chapter 7 of ASCE 7-05 and using the snow load maps, the roof snow load and drift values were obtained. The factors used to calculate the flat roof snow load are summarized in Figure 17. A flat roof snow load of 21 psf was calculated which matched the structural drawings. Due to the different roof heights, drift was considered at multiple locations. A summary of the snow and drift calculations and results can be found in Figure 18.

Flat Roof Snow Load Calculations	
Variable	Value
Ground Snow Load - p_g (psf)	25
Exposure Factor - C_e	1
Temperature Factor - C_t	1
Importance Factor - I	1.2
Flat Roof Snow Load - p_f (psf)	21

Figure 17:
Summary of roof snow load values

Snow Drift Load Calculations								
Roof Levels	Windward				Leeward			
	L_u (ft)	h_d (ft)	p_d (psf)	w_d (ft)	L_u (ft)	h_d (ft)	p_d (psf)	w_d (ft)
1 and 2	39.83	1.55	26.80	6.22	175.33	4.35	75.10	17.42
2 and 3	159.5	3.13	53.98	12.52	46.33	2.26	38.92	9.03
2 and 4	159.5	3.13	53.98	12.52	31.33	1.80	31.00	7.19
1 and 3	37.33	1.50	25.82	5.99	50.17	2.36	40.67	9.43
3 and 4	19.33	0.98	16.91	3.92	30.83	1.78	30.70	7.12

Figure 18:
Summary of roof snow drift calculations

Lateral Loads:

In order to obtain a better understanding of how the structural system of the SPT responds to lateral loads, both wind and seismic loads were calculated and then applied to a lateral model of the structure created in ETABS. Hand calculations for both of these sections can be found in Appendices B and C for wind and seismic respectively.

Wind Loads:

Using the Method 2 procedure from Chapter 6 of ASCE 7-05 (Main Wind Force Resisting System – MWRFS), wind loads and pressures were found and applied to the building to find the story forces and eventually leading to the calculation of both the base shear and the overturning moment.

In order for Method 2 to be applied to the South Patient Tower, several simplifying assumptions had to be made. The main assumption involved in calculating the wind forces was ignoring the existing attached hospital due to the expansion joint that exists between the current structure and the existing portion. Also, because of the irregular shape of the first three levels of the SPT, the shape was transformed into a rectangle with the same area as the original footprint of the building. If the general shape for the third floor was used for the remaining upper portion of the building, the calculated forces would have been overestimated by a significant portion. To prevent this from happening, the tower itself was modeled with different proportions compared to the lower three levels (see Figure 19a and 19b). Using these two separate structures allowed for a better estimation of the distribution of wind pressure and forces to each floor. Two different L/B values were used to obtain the leeward pressure. Because of the mechanical penthouse, the mean roof height used to calculate q_h was taken as the top of that structure, which is at 175' but the structure was assumed to end at the main roof level (two levels below top of penthouse). Since the penthouse is roughly 15% of a typical floor plan and spans over to the existing portion of the hospital, it was concluded that the wind forces would be negligible and shared between the two buildings.

The wind loads are collected by the components and cladding of the exterior of the building. The façade then transfers these wind forces to the slab system, which in turn sheds the load to the lateral force resisting system within the building and down to the foundation.

Load combinations were determined using Figure 6-9 of ASCE 7-05. The four different combinations were then broken up into the X and Y direction and then combined with the load combinations in Chapter 2 of ASCE 7-05. The wind load combinations broken up into the four different cases with accidental moments are summarized in Figure 20.

Most of the calculations for the wind section are achieved through the use of Microsoft Excel to simplify the process. The story forces at each level include both the windward and the leeward pressures. Internal pressures have been calculated but not included in the story forces due to the fact that they effectively cancel out. The following few pages contain figures and diagrams representing the pressures and forces (unfactored) for both the North-South and East-West directions. The base shear in the E-W

direction was significantly higher than the N-S direction due to the slender nature of the building, and in turn the resulting moment also ended up being considerably greater.

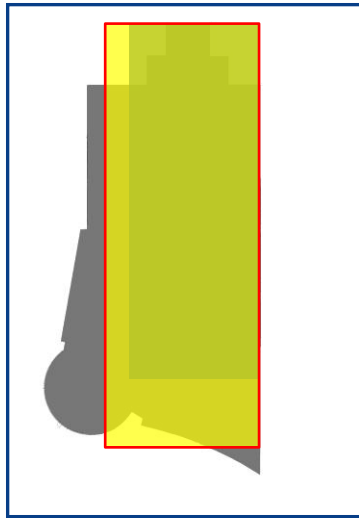

Figure 19a:
Plan view of the two separate wind towers

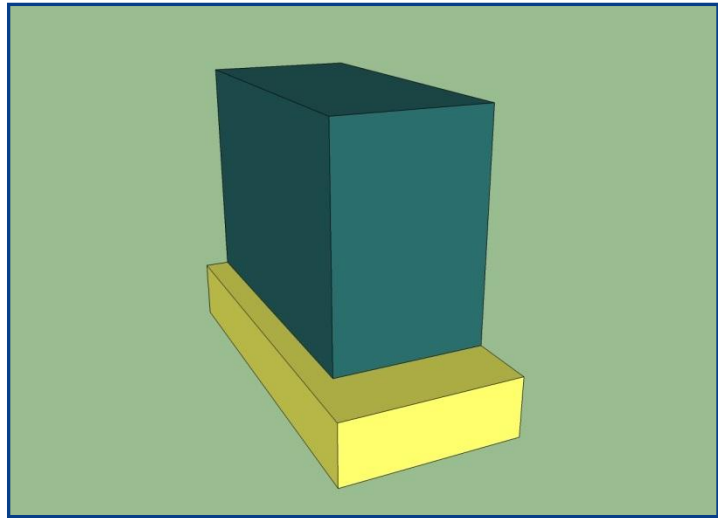

Figure 19b:
Perspective view of the two separate wind towers

Load Combinations for Serviceability (1.0 Wind)			
Wind	Case 1	$P_{WX} + P_{LX}$	
		$P_{WX} + P_{LY}$	
	Case 2	$0.75P_{WX} + 0.75P_{LX} + M_T$	$M_T = 0.75(P_{WX} + P_{LX})B_x e_x$ $e_x = \pm 0.15B_x$
		$0.75P_{WY} + 0.75P_{LY} + M_T$	$M_T = 0.75(P_{WY} + P_{LY})B_y e_y$ $e_y = \pm 0.15B_y$
	Case 3	$0.75P_{WX} + 0.75P_{LX} + 0.75P_{WY} + 0.75P_{LY}$	
	Case 4	$0.563P_{WX} + 0.563P_{LX} + 0.563P_{WY} + 0.563P_{LY} + M_T$	$M_T = 0.563(P_{WX} + P_{LX})B_x e_x + 0.563(P_{WY} + P_{LY})B_y e_y$ $e_x = \pm 0.15B_x$ $e_y = \pm 0.15B_y$

Figure 20:
The four cases used for wind in determining displacements and drifts

Wind Pressures N-S Direction							
Wall Type	Floor	Distances (ft)	Wind Pressures (psf)	Internal Pressure (psf)		Net Pressure (psf)	
				(+)(G _{C_{pi}})	(-)(G _{C_{pi}})	(+)(G _{C_{pi}})	(-)(G _{C_{pi}})
0' - 36.17'							
Windward Walls	Ground	0	7.86	4.23	-4.23	3.63	12.09
	1st	10.83	7.86	4.23	-4.23	3.63	12.09
	2nd	24.83	9.08	4.23	-4.23	4.85	13.31
	3rd	36.17	10.16	4.23	-4.23	5.93	14.39
Leeward Walls	All	All	-5.80	4.23	-4.23	-10.03	-1.57
Side Walls	All	All	-13.99	4.23	-4.23	-18.22	-9.76
36.17' - 175'							
Windward Walls	4th	47.50	10.99	4.23	-4.23	6.76	15.22
	5th	58.67	11.65	4.23	-4.23	7.42	15.88
	6th	72.93	12.43	4.23	-4.23	8.20	16.66
	7th	84.17	13.00	4.23	-4.23	8.77	17.23
	8th	95.50	13.46	4.23	-4.23	9.23	17.69
	9th	106.83	13.88	4.23	-4.23	9.65	18.11
	10th	118.17	14.27	4.23	-4.23	10.04	18.50
	11th	129.50	14.67	4.23	-4.23	10.44	18.90
Penthouse	144.83	15.16	4.23	-4.23	10.93	19.39	
Leeward Walls	All	All	-5.90	4.23	-4.23	-10.13	-1.67
Side Walls	All	All	-13.99	4.23	-4.23	-18.22	-9.76
Roof	N/A	0-87.5	-24.65	4.23	-4.23	-28.88	-20.42
	N/A	87.5-175	-14.65	4.23	-4.23	-18.88	-10.42
	N/A	175-350	-13.33	4.23	-4.23	-17.56	-9.10
	N/A	>350	-12.66	4.23	-4.23	-16.89	-8.43

Figure 21:
List of N-S direction wind pressures

Wind Forces N-S Direction									
Floor Level	Elevation (ft)	Tributary Below		Tributary Above		Story Force (k)	Story Shear (k)	Overturning Moment (k-ft)	
		Height (ft)	Area (ft ²)	Height (ft)	Area (ft ²)				
Ground	0.00	N/A	0.00	5.42	568.58	7.77	244.45	0.00	
1st	10.83	5.42	568.58	7.00	735.00	18.70	236.68	202.56	
2nd	24.83	7.00	735.00	5.67	595.35	20.44	217.98	507.49	
3rd	36.17	5.67	595.35	5.67	510.00	18.12	197.54	655.24	
4th	47.50	5.67	510.00	5.58	502.50	17.43	179.42	828.11	
5th	58.67	5.58	502.50	7.13	641.70	20.58	161.99	1207.50	
6th	72.93	7.13	641.70	5.62	505.80	21.32	141.41	1555.01	
7th	84.17	5.62	505.80	5.67	509.85	19.43	120.09	1635.45	
8th	95.50	5.67	509.85	5.67	509.85	19.96	100.66	1905.75	
9th	106.83	5.67	509.85	5.67	510.30	20.38	80.70	2176.94	
10th	118.17	5.67	510.30	5.67	509.85	20.78	60.32	2455.62	
11th	129.50	5.67	509.85	7.67	689.85	25.02	39.54	3239.55	
Roof	144.83	7.67	689.85	N/A	0.00	14.53	14.53	2104.13	
Total Base Shear =						244.45	Total Overturning Moment =		18,473.36 k-ft

Figure 22:
List of N-S direction wind forces

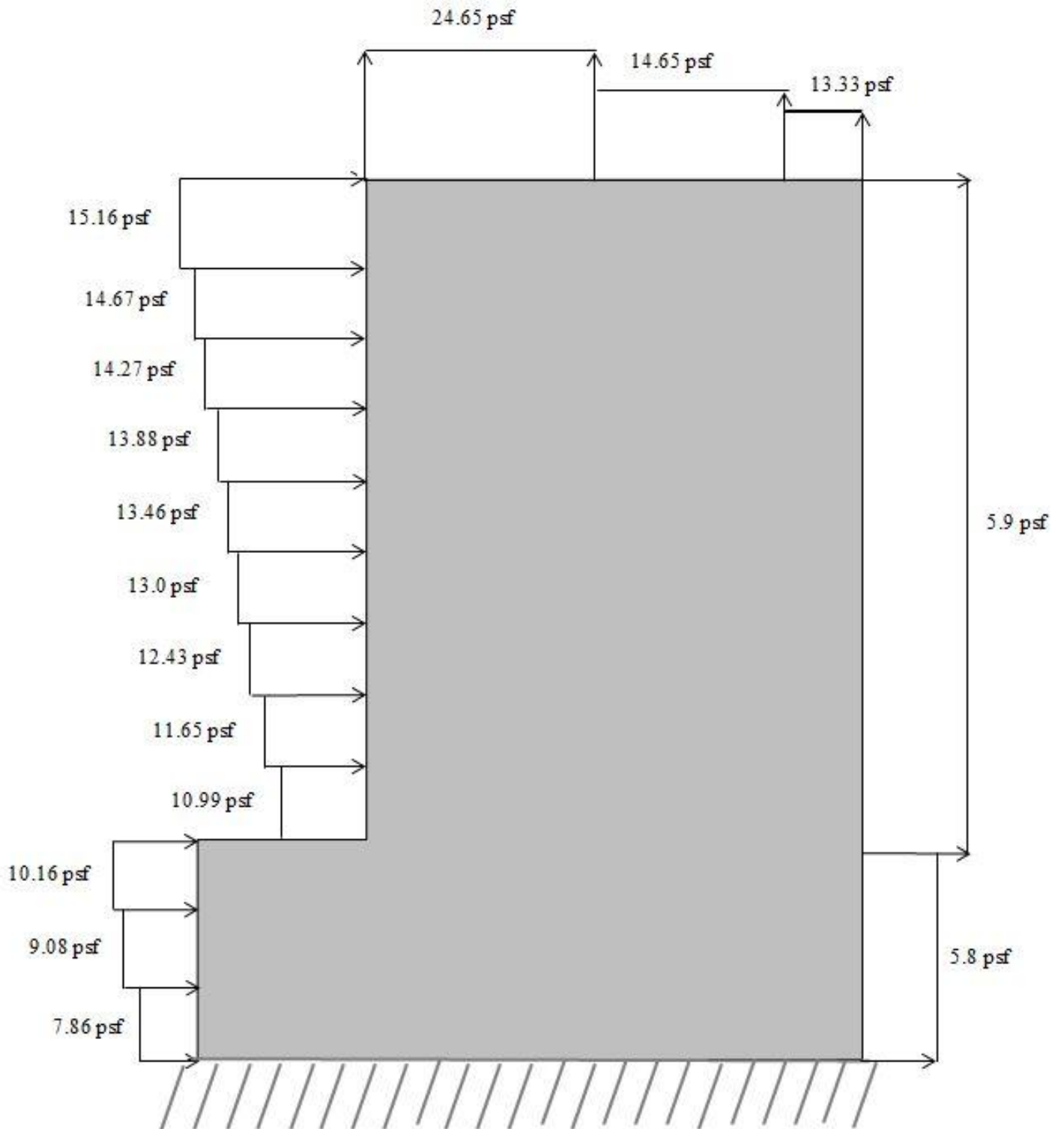

Figure 23a:
Diagram of N-S direction wind pressures

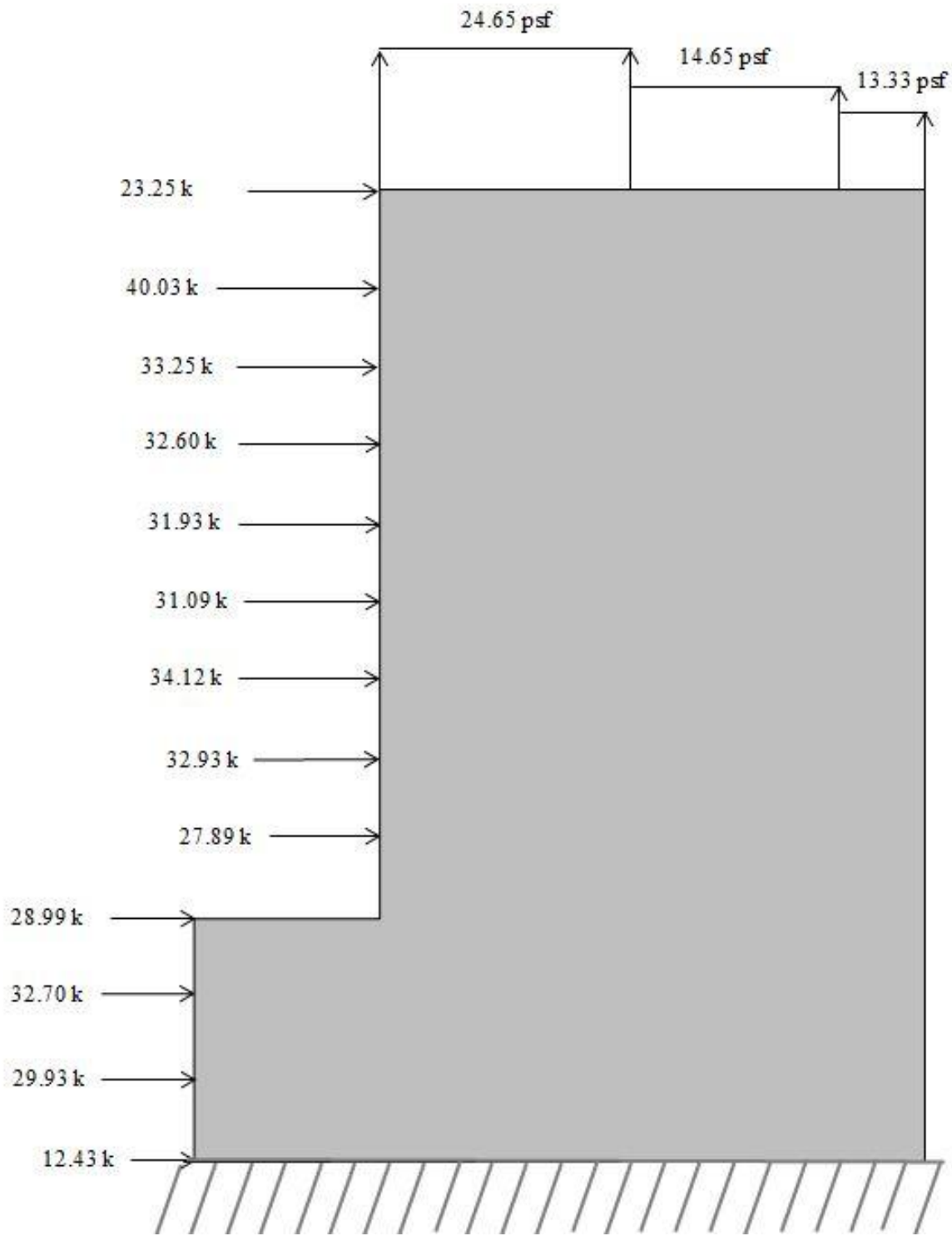
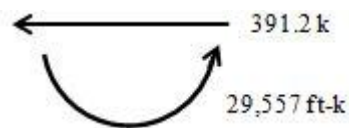

Figure 23b:

Diagram of N-S direction wind pressures

*Story forces include 1.6 W Factor as well as the Leeward wall pressures



Wind Pressures E-W Direction							
Wall Type	Floor	Distances (ft)	Wind Pressures (psf)	Internal Pressure (psf)		Net Pressure (psf)	
				(+)(G _{C_{pi}})	(-)(G _{C_{pi}})	(+)(G _{C_{pi}})	(-)(G _{C_{pi}})
0' - 36.17'							
Windward Walls	Ground	0	7.86	4.23	-4.23	3.63	12.09
	1st	10.83	7.86	4.23	-4.23	3.63	12.09
	2nd	24.83	9.08	4.23	-4.23	4.85	13.31
	3rd	36.17	10.16	4.23	-4.23	5.93	14.39
Leeward Walls	All	All	-9.99	4.23	-4.23	-14.22	-5.76
Side Walls	All	All	-13.99	4.23	-4.23	-18.22	-9.76
36.17' - 175'							
Windward Walls	4th	47.50	10.99	4.23	-4.23	6.76	15.22
	5th	58.67	11.65	4.23	-4.23	7.42	15.88
	6th	72.93	12.43	4.23	-4.23	8.20	16.66
	7th	84.17	13.00	4.23	-4.23	8.77	17.23
	8th	95.50	13.46	4.23	-4.23	9.23	17.69
	9th	106.83	13.88	4.23	-4.23	9.65	18.11
	10th	118.17	14.27	4.23	-4.23	10.04	18.50
	11th	129.50	14.67	4.23	-4.23	10.44	18.90
Penthouse	144.83	15.16	4.23	-4.23	10.93	19.39	
Leeward Walls	All	All	-9.99	4.23	-4.23	-14.22	-5.76
Side Walls	All	All	-13.99	4.23	-4.23	-18.22	-9.76
Roof	N/A	0-87.5	-20.79	4.23	-4.23	-25.02	-16.56
	N/A	87.5-175	-13.99	4.23	-4.23	-18.22	-9.76
	N/A	175-350	-13.99	4.23	-4.23	-18.22	-9.76
	N/A	>350	-13.99	4.23	-4.23	-18.22	-9.76

Figure 24:
List of E-W direction wind pressures

Wind Forces E-W Direction									
Floor Level	Elevation (ft)	Tributary Below		Tributary Above		Story Force (k)	Story Shear (k)	Overturning Moment (k-ft)	
		Height (ft)	Area (ft ²)	Height (ft)	Area (ft ²)				
Ground	0.00	N/A	0.00	5.42	1250.87	22.33	642.42	0.00	
1st	10.83	5.42	1250.87	7.00	1617.00	53.16	620.09	575.77	
2nd	24.83	7.00	1617.00	5.67	1309.77	57.23	566.93	1420.97	
3rd	36.17	5.67	1309.77	5.67	1080.92	49.07	509.70	1774.84	
4th	47.50	5.67	1080.92	5.58	1065.02	45.72	460.63	2172.07	
5th	58.67	5.58	1065.02	7.13	1360.05	53.54	414.91	3141.15	
6th	72.93	7.13	1360.05	5.62	1072.02	55.14	361.37	4021.21	
7th	84.17	5.62	1072.02	5.67	1080.60	49.99	306.23	4207.29	
8th	95.50	5.67	1080.60	5.67	1080.60	51.13	256.24	4883.29	
9th	106.83	5.67	1080.60	5.67	1081.55	52.03	205.11	5558.62	
10th	118.17	5.67	1081.55	5.67	1080.60	52.89	153.08	6249.54	
11th	129.50	5.67	1080.60	7.67	1462.10	63.42	100.19	8212.81	
Roof	144.83	7.67	1462.10	N/A	0.00	36.77	36.77	5325.66	
Total Base Shear =						642.42	Total Overturning Moment =		47,543.22 k-ft

Figure 25:
List of E-W direction wind forces

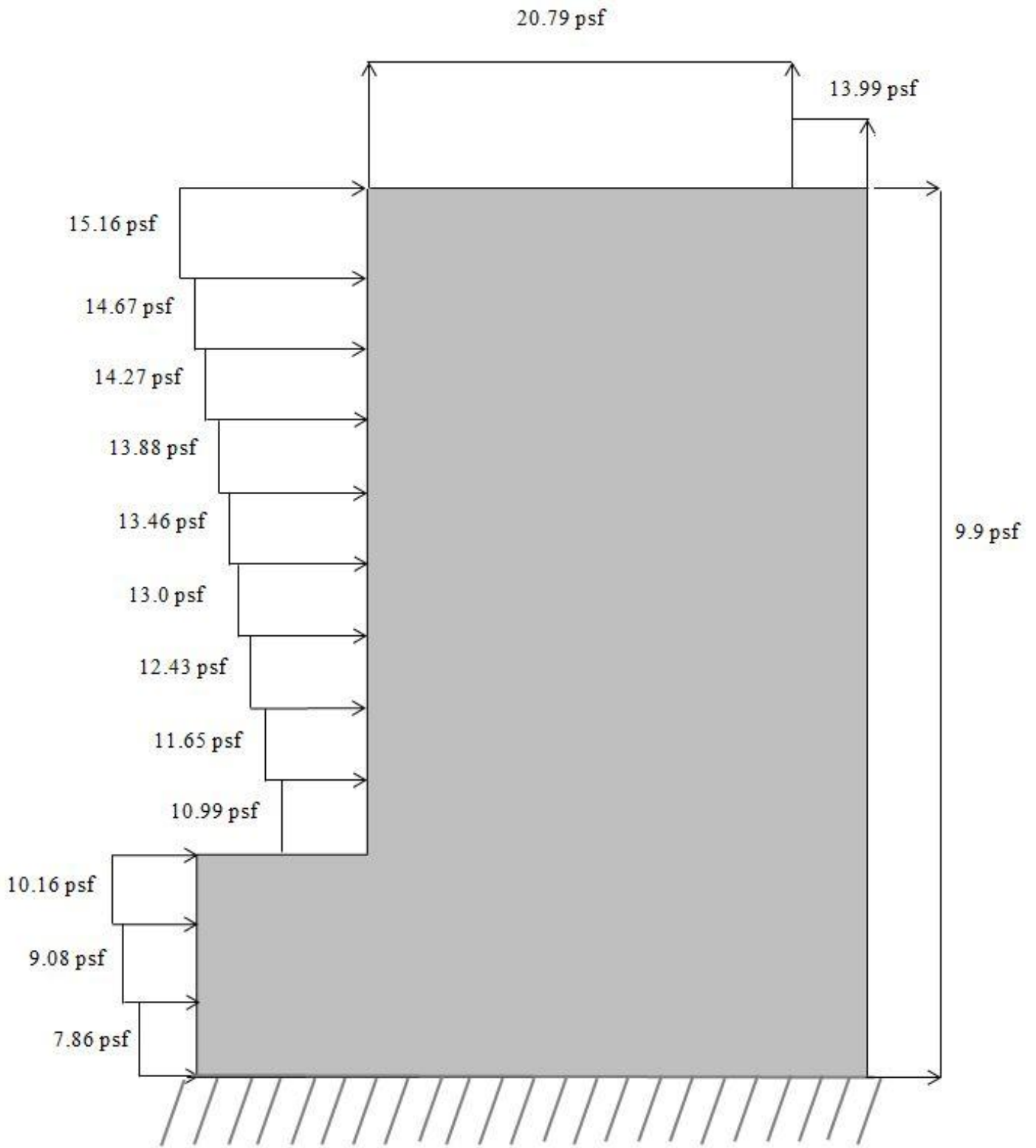

Figure 26a:
Diagram of E-W direction wind pressures

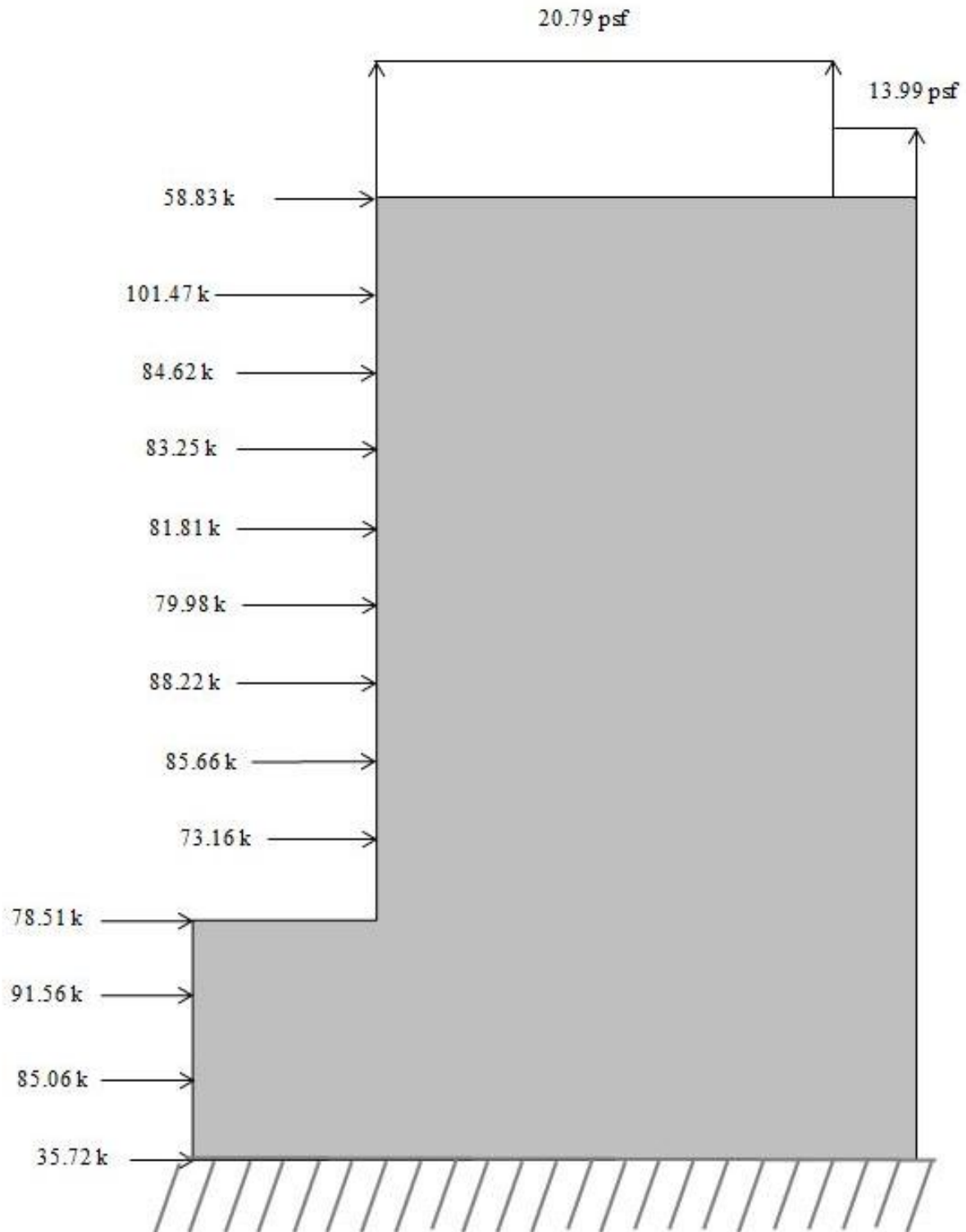

Figure 26b:

Diagram of E-W direction wind pressures

*Story forces include 1.6 W Factor as well as the Leeward wall pressures

Seismic Loads:

Using Chapters 11 and 12 of ASCE 7-05, the seismic loads were calculated with the Equivalent Lateral Force procedure. The approximate fundamental period for the structure was estimated using §12.8.2.1 and the “All other Structural Systems” category. The increased stiffness from the connected portion of the existing hospital was ignored in this study of the seismic loads since the expansion joint will separate the two buildings completely from each other. The movement of the loads due to seismic activity originates where most of the mass is locked, the two-way slab system. The slabs then transfer the load to the shear walls and moment frames which in turn carry the forces down to the foundation.

The seismic loads generated a base shear of approximately 747 k which only differed by about 6.7% from the structural drawings. This slight discrepancy is likely due to a difference in the calculated weight. One other difference that most likely caused the variation was that the structural drawings called out slightly different S_5 and S_1 values. One assumption made to simplify the seismic analysis revolved around the penthouse. Because the penthouse spans from both the existing hospital and the South Patient Tower, the penthouse was not included in the height of the overall structure. The main reason behind this thought process was that the story forces from the seismic loads will be shared between the buildings. The weight of the penthouse was included and lumped on the main roof level to increase the story forces seen by that level. Also, since the Wind forces were obtained using the main roof level as the top (ignoring the penthouse in calculations), in order to accurately compare the two, the same level was used as the overall building height. Figures 28 and 29 list and display the story forces.

Load Combinations for Serviceability (1.0 Earthquake)		
Earthquake	Case 1	$1.0E_x + M_{zx}$
	Case 2	$1.0E_y + M_{zy}$

Figure 27:
Serviceability combinations considering seismic loads

Seismic Forces N-S and E-W Direction							
Level	Story Weight, w_x (k)	Story Height, h_x (ft)	$w_x h_x^k$	C_{vx}	Story Force (k)	Story Shear (k)	Overtopping Moment (k-ft)
Ground	N/A	0	0	0	0	692.50	0
1st	4392.7	10.67	155808.37	0.0052	3.86	692.50	41.13073686
2nd	2417.8	24.67	303505.33	0.0101	7.51	688.64	185.2779646
3rd	3902.0	36.00	866097.18	0.0287	21.43	681.13	771.6424501
4th	3010.7	47.33	1009605.78	0.0334	24.99	659.70	1182.676325
5th	3285.3	58.67	1522642.55	0.0504	37.68	634.71	2210.733348
6th	3078.1	72.67	1969868.32	0.0652	48.75	597.03	3542.578011
7th	3010.7	84.00	2397250.26	0.0794	59.33	548.28	4983.559489
8th	3010.7	95.33	2901211.23	0.0961	71.80	488.95	6844.963165
9th	3010.7	106.67	3436576.58	0.1138	85.05	417.15	9071.972736
10th	3010.7	118.00	4001651.25	0.1325	99.03	332.10	11686.0632
11th	3065.8	129.33	4678992.06	0.1550	115.80	233.07	14976.48054
Penthouse/Roof	3831.1	145.00	6947035.33	0.2301	171.93	117.27	24929.55332
						Base Shear =	747.16 k
						Total Overtopping Moment =	80,426.63 k-ft

Figure 28:
List of seismic forces for both directions

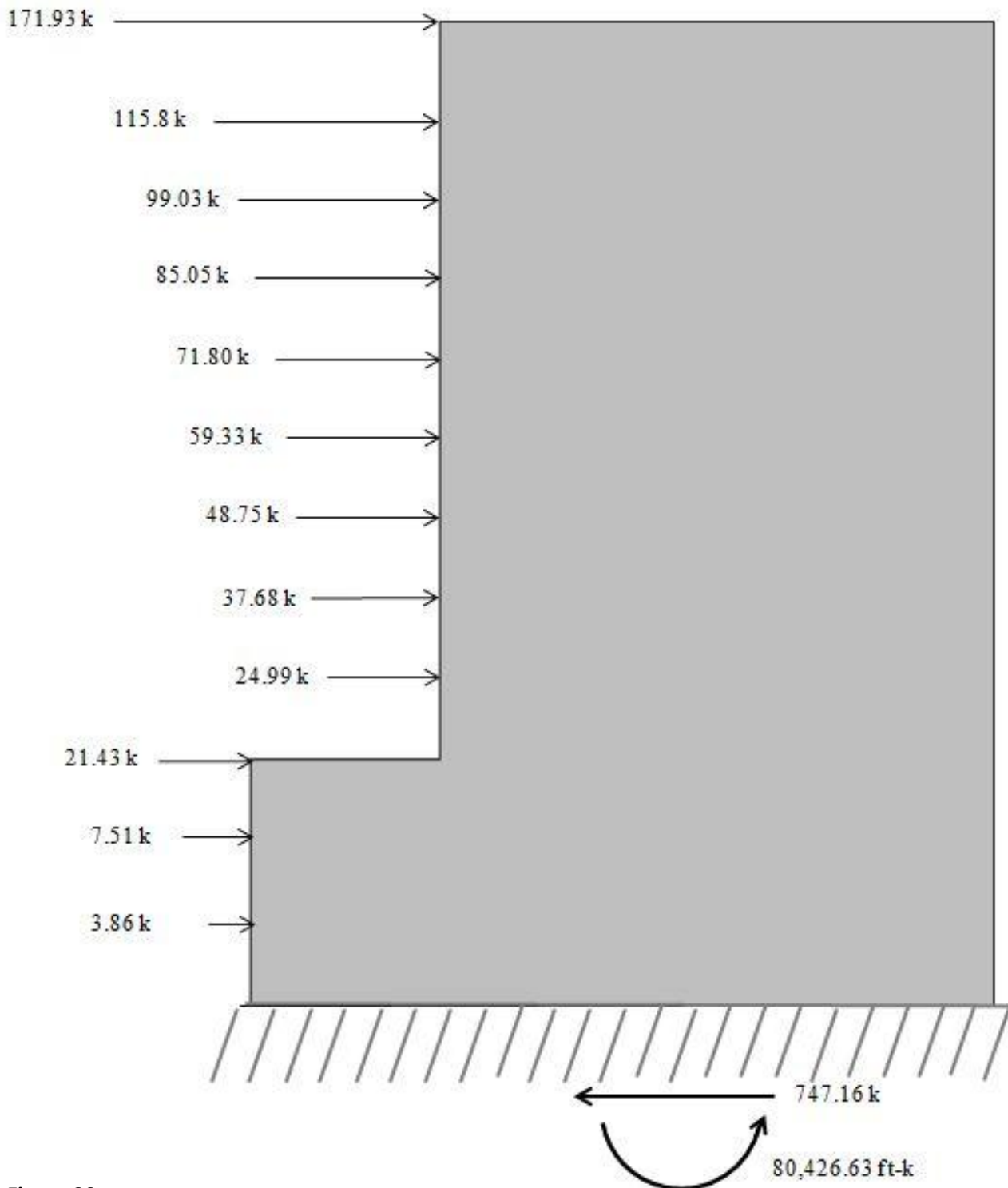

Figure 29:
Diagram of N-S / E-W earthquake forces

Problem Statement:

The current structural system for the South Patient Tower is sufficient for both strength and serviceability requirements as determined in Technical Reports 1 and 3. However, as mentioned in the Lateral System section above, the one area of concern for the structure pertains to the lateral system in the East-West direction. The majority of the lateral system is situated along the North-South direction to prevent the structure from damaging the existing hospital (pounding effects). The structure as it stands currently undergoes significant torsional issues when the loads are applied in the East-West direction. In the current location, the controlling load case depends on the direction of interest as well as the height of the floor level. The majority of the upper levels are controlled by seismic loads whereas the lower levels see wind as the controlling factor.

Therefore, a scenario has been created in which the University of California – Davis has decided to design and construct a similar hospital patient tower on campus. Because it is believed that the structure will be classified into a higher seismic design category, the structure will be subjected to more severe strength and serviceability checks. Since the structure encompasses intensive care units and medical/surgical rooms, the building should be designed for an ASCE 41-06 Structural Performance Level of “S-1 Immediate Occupancy” to allow immediate access to the facilities directly after an earthquake with only minor damage to the structure. A table explaining the structural requirements for the various S levels can be found in Figure 30 on the following page (taken from FEMA 356).

Therefore, a structural system must be designed to provide the adequate strength and serviceability to obtain an S-1 structural performance level as defined in ASCE 41-06. This must be achieved with as little impact to the architecture, cost and schedule of the current structure.

Table C1-3 Structural Performance Levels and Damage^{1, 2, 3}—Vertical Elements

Elements	Type	Structural Performance Levels		
		Collapse Prevention S-5	Life Safety S-3	Immediate Occupancy S-1
Concrete Frames	Primary	Extensive cracking and hinge formation in ductile elements. Limited cracking and/or splice failure in some nonductile columns. Severe damage in short columns.	Extensive damage to beams. Spalling of cover and shear cracking (<1/8" width) for ductile columns. Minor spalling in nonductile columns. Joint cracks <1/8" wide.	Minor hairline cracking. Limited yielding possible at a few locations. No crushing (strains below 0.003).
	Secondary	Extensive spalling in columns (limited shortening) and beams. Severe joint damage. Some reinforcing buckled.	Extensive cracking and hinge formation in ductile elements. Limited cracking and/or splice failure in some nonductile columns. Severe damage in short columns.	Minor spalling in a few places in ductile columns and beams. Flexural cracking in beams and columns. Shear cracking in joints <1/16" width.
	Drift	4% transient or permanent	2% transient; 1% permanent	1% transient; negligible permanent
Steel Moment Frames	Primary	Extensive distortion of beams and column panels. Many fractures at moment connections, but shear connections remain intact.	Hinges form. Local buckling of some beam elements. Severe joint distortion; isolated moment connection fractures, but shear connections remain intact. A few elements may experience partial fracture.	Minor local yielding at a few places. No fractures. Minor buckling or observable permanent distortion of members.
	Secondary	Same as primary.	Extensive distortion of beams and column panels. Many fractures at moment connections, but shear connections remain intact.	Same as primary.
	Drift	5% transient or permanent	2.5% transient; 1% permanent	0.7% transient; negligible permanent

Table C1-3 Structural Performance Levels and Damage^{1, 2, 3}—Vertical Elements (continued)

Elements	Type	Structural Performance Levels		
		Collapse Prevention S-5	Life Safety S-3	Immediate Occupancy S-1
Concrete Walls	Primary	Major flexural and shear cracks and voids. Sliding at joints. Extensive crushing and buckling of reinforcement. Failure around openings. Severe boundary element damage. Coupling beams shattered and virtually disintegrated.	Some boundary element stress, including limited buckling of reinforcement. Some sliding at joints. Damage around openings. Some crushing and flexural cracking. Coupling beams: extensive shear and flexural cracks; some crushing, but concrete generally remains in place.	Minor hairline cracking of walls, <1/16" wide. Coupling beams experience cracking <1/8" width.
	Secondary	Panels shattered and virtually disintegrated.	Major flexural and shear cracks. Sliding at joints. Extensive crushing. Failure around openings. Severe boundary element damage. Coupling beams shattered and virtually disintegrated.	Minor hairline cracking of walls. Some evidence of sliding at construction joints. Coupling beams experience cracks <1/8" width. Minor spalling.
	Drift	2% transient or permanent	1% transient; 0.5% permanent	0.5% transient; negligible permanent

Figure 30:
Performance requirements for Concrete Frames and Walls taken from FEMA 356 (similar to ASCE 41-06)

Problem Solution:

The existing lateral system found in the South Patient Tower will be redesigned using a one-way floor slab system that was investigated in Technical Report 2. The one-way slab with moment frames will increase the lateral stiffness of the structure in the East-West direction and help correct the torsional irregularity problem. Upon completion of a suitable lateral system, the building will be moved to Sacramento, California. Next, new seismic loads will be calculated to determine the controlling load combinations. Two separate structures will then be created using ETABS to compare the effectiveness of these structures for higher seismic loads and the S-1 performance requirements:

- One-way slab floor system with a traditional fixed base (CA – Fixed Model)
- One-way slab floor system utilizing base isolators (CA – Base Isolation Model)

The one-way slab floor system chosen for this academic exercise will be germane to the lateral force resisting system due to the increased moment frames situated in the East-West direction to help counteract the slender nature of the structure. The current structure's lateral system becomes extremely flexible at the far end opposite the connection to the existing hospital.

Because the interstory drifts were found to be excessive in Technical Report 3, the redesign of the lateral system should help improve the serviceability criteria for the present location. Once the structure is moved to California, the higher seismic loads could potentially produce an interstory drift issue with the newly designed one-way slab system. This can be attributed to the displacement amplitude factor used to increase the displacements and the interstory drifts from the elastic levels to the more accurate code levels. One solution is the use of base isolators. These include a range of different devices to provide flexibility into the building by creating a point of energy dissipation in the structure. The base isolator increases the flexibility/period of the building, which in turn reduces the forces seen by the structure. However, with this increase in period, there also is an increase in overall displacement of the structure. This leads to another motive for using the one-way slab floor system. To limit the overall displacement of the structure with base isolation, a stiffer structure should be used to manage the increased period and the displacements/interstory drifts. On the other hand, the general ideal behind using base isolators is that most of the ground movement produced from the earthquake will not be transmitted to the building and, therefore, the structure as a whole will experience much smaller floor accelerations and interstory drifts. The key to preventing/eliminating structural and non-structural damage (façade panels and various architectural details) is to minimize interstory drifts. Various types of base isolators are currently being used in construction projects to date. An example of a friction pendulum can be seen to the right in Figure 31. This device along with lead-rubber bearings (Figure 32) and high-damping rubber bearings are the most popular devices in the United States for seismic isolation. The friction pendulum allows the structure to

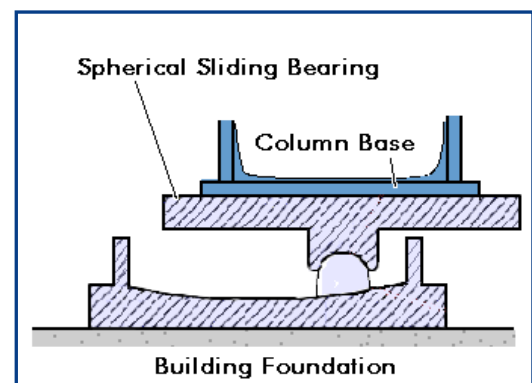

Figure 31: Friction pendulum, taken from MCEER's website

displace both vertically and horizontally as the ball bearing travels in the bowl, where the lead rubber bearing (LRB) provides an energy dissipating core to help dampen the energy/forces during an earthquake. For this final report, the lead rubber bearing (LRB) isolators were chosen due to their increasing use in the United States and the damping properties associated with the devices.

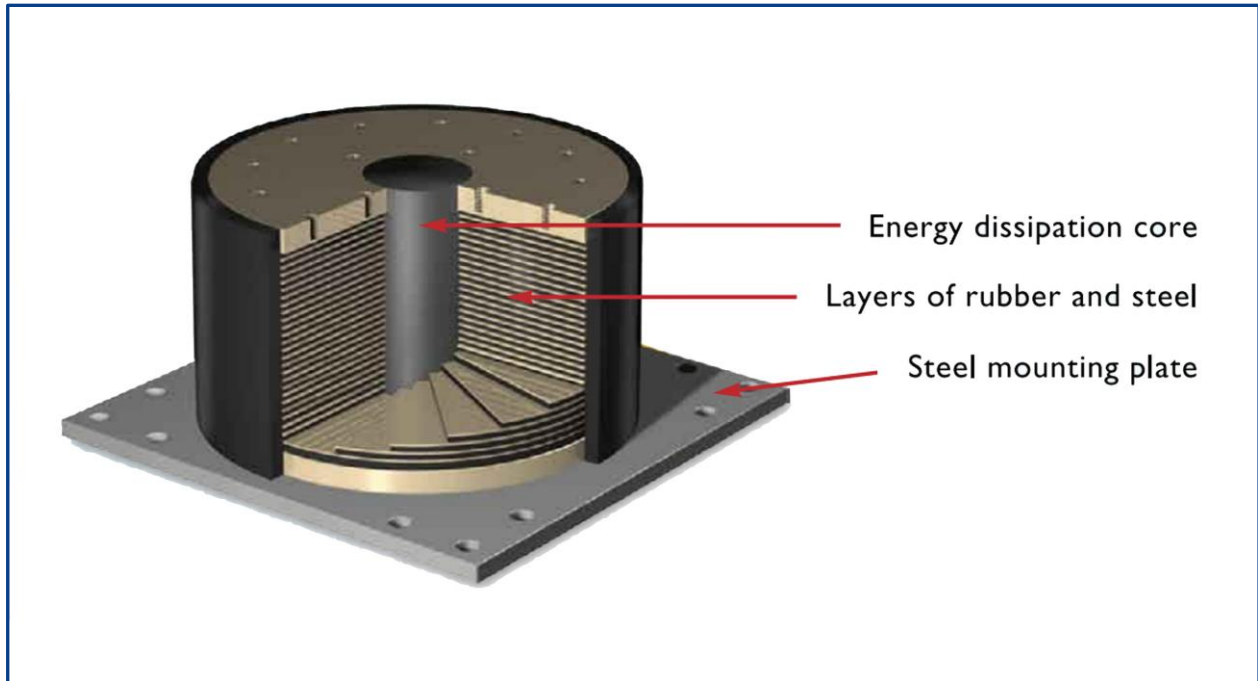

Figure 32:

Lead Rubber Bearing (LRB), taken from Teratec's website

Breadth Topics:

Construction Management Breadth:

To address the integrated nature of the Architectural Engineering program, two separate studies were conducted in the other options and are included in this report. The first being a construction management breadth, which consists of developing costs and schedules for the two structures located in Sacramento, CA. Using RS means to determine the duration and costs of the superstructure components, the two different systems could then be evaluated and the resulting data was used to help compare the designs to determine the relative efficiency of base isolation when compared to a fixed-base system of similar performance requirements.

Architectural/Facade Breadth:

The second breadth study attempts to determine if a modification to the glazing system has an impact on the existing façade. With a high percentage of the façade being composed of a curtain wall system, changing the properties of the wall could lead to significant alterations in the heating/cooling loads for the main hospital building. Using H.A.M Toolbox, the design values listed on the drawings were checked for accuracy and the creation of a TRACE model allowed for the calculation of the loads for a typical patient room as well as the entire main hospital as a whole entity.

MAE Coursework:

As a requirement for completing the MAE degree, graduate level coursework must be incorporated into the final project. Much of the calculations drew upon material learned in the MAE courses. Computer modeling was an integral tool utilized in the completion of the redesign as well as the modeling of the base isolators. Concepts such as insertion points, rigid diaphragm constraints and modal analysis results were applied to ETABS models for the redesign of the South Patient Tower and were taught in AE 597A – *Advanced Computer Modeling*.

Employing techniques such as the Modal Response Spectrum Analysis and Time History Functions subjected the various structures to extreme earthquakes. The limitations and requirements for a concrete structure in seismic locations relied heavily on material presented in AE 538 – *Earthquake Resistant Design*. Design procedures used to implement performance-based designs were of particular use and covered extensively in the course.

Finally, coursework from AE 542 – *Building Enclosure Science and Design* was integrated into the redesign of the glazing system. Utilizing computer programs such as H.A.M. Toolbox and TRACE were covered throughout the course. Although TRACE was not specifically taught in class, the basic concepts of heat, air and moisture will be extrapolated to create specific models within the program and to design a reasonable alternative to the existing enclosure system.

Structural Depth

The redesigns were done in an order that allowed for a logical progression. First, the gravity system for the structure was redesigned to a one-way slab in place of the existing two-way slab. This was accomplished by selecting a typical bay and designing the slab, beams/girders and joists in these bays by hand. Because the loading is similar for each floor, the gravity system calculation was only performed for one level with the other floors experiencing a similar layout and design. The complete set of hand calculations for the gravity redesign can be found in Appendix D at the end of this report. The redesign to a one-way slab allowed for an increase in the number of moment frames in the laterally weak direction (E-W direction), which was done in preparation for the move to Sacramento, California. As calculated in Technical Report #3, the patient tower was quite flexible with a period of about 2.9 sec. It was known that the usage of base isolators was more effective with more rigid structures; therefore the increase in the moment frames will help counteract the flexible nature of the building structure. Once an adequate gravity system was in place, the lateral system was analyzed for the seismic loads that are generated from the relocation to Sacramento, CA. The following sections contain the progression to reach the designs for both the fixed base system (CA – Fixed Model) and the base isolated structure (CA – Base Isolation Model) with background information included.

Gravity Redesign:

The gravity redesign was mainly created to have a baseline structure to serve as the logical comparison between the original two-way flat slab structure and rest of the proposal. As mentioned above, the main reason for the modification to a one-way slab was to increase the number of moment frames in the E-W direction and ultimately decrease the torsional aspect of the existing structure. The hand calculations pertaining to the design of the gravity system can be found in Appendix D. Because the columns were checked and accounted for in Technical Report #1, the sizes of the members remained exactly the same as those used for the existing structure (axial load capacities were deemed adequate). The existing floor plan is depicted on the following page in Figure 33. The column locations and the existing moment frames are shown as well as the seven shear walls situated around the elevator core (northern section) and the staircase (central location).

For the existing two-way flat slab system, the overall lateral system was found to be adequate in Technical Report #3; however, the lateral system all together experiences large torsional effects due to the lack of an adequate force resisting member in the direction of question. One option to increase the lateral system was by adding shear walls in the X-Direction, but upon further review of the architectural drawings, the location of any shear walls towards the southern part of the structure was not feasible unless major architectural changes took place. Directly beside the existing floor plan on the following page is the one-way slab redesign. The next option undertaken was the addition of moment frames. The added moment frames are beneficial to the lateral system for two distinct reasons. One being that the frames take a portion of the load in the X-Direction to help alleviate the torsional irregularities associated with each floor. Although the torsional aspect is not completely eliminated with the addition of the moment frames, the effects of the new lateral system reduces the amplification factor (A_x) and torsional irregularities on the upper floors (horizontal irregularity 1b to 1a).

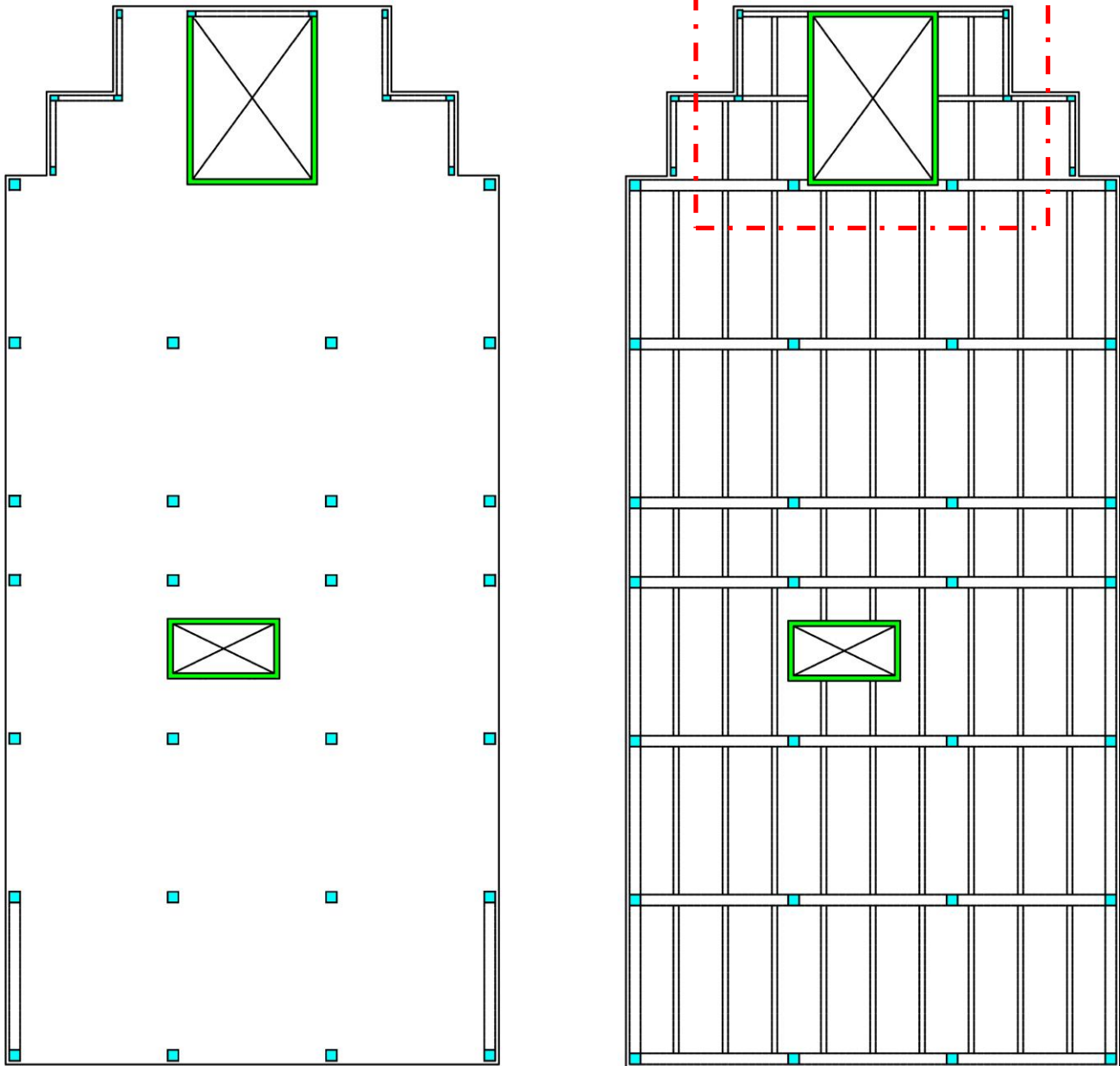
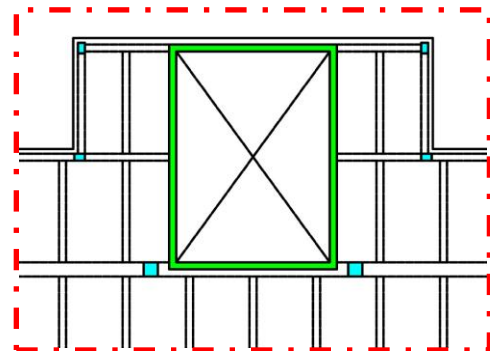

Figure 33:
The existing two-way concrete slab (left) and the redesigned one-way slab (right) with the enlarged section highlighted in red



The concrete moment frames for the redesigned one-way slab are typically 24 in. x 24 in. in both the X and Y-Directions. The joists are spaced at 9 ft 8 in. on center and run in the N-S direction while the bay sizes remained the same as the existing structure (29 ft x 29 ft). Full detailed hand calculations for the redesign can be found in Appendix D with required reinforcement values for the slab, beam/girder and joists. A summary of the findings is shown below in Figure 34.

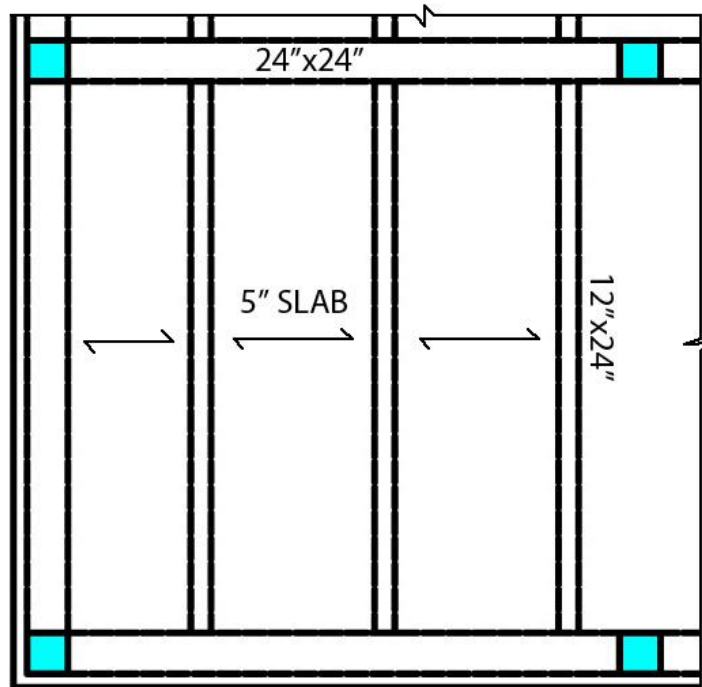

Figure 34:
Dimensions for designed one-way slab system

Using RAM Concept to model the one-way slab provided a tool to check hand calculated deflections and reinforcement with the output provided from RAM. The reinforcement obtained from RAM Concept nearly matched the hand calculations with only a percent difference of about 5%. Upon the reproduction of the reinforcement produced by hand, the gravity system adequately carries the gravity loading for a typical floor. The following figure displays the reinforcement necessary for the various structural members of the designed one-way slab system and Figure 36 on the following page displays images from RAM Concept.

Figure 35:
Reinforcement for one-way slab design

Designed One-Way Floor Slab System			
Member	Dimensions	Location	Reinforcement
Slab	5"	Top/Bottom	# 4 @ 12"
		Transverse	# 4 @ 18"
Joist	12"x24"	At Support (top)	(4) # 6's
		At Midspan (bottom)	(3) # 6's
		At Support (top)	(4) # 6's
Girder	24"x24"	At Support (top)	(5) # 9's
		At Midspan (bottom)	(4) # 8's
		At Support (top)	(5) # 9's

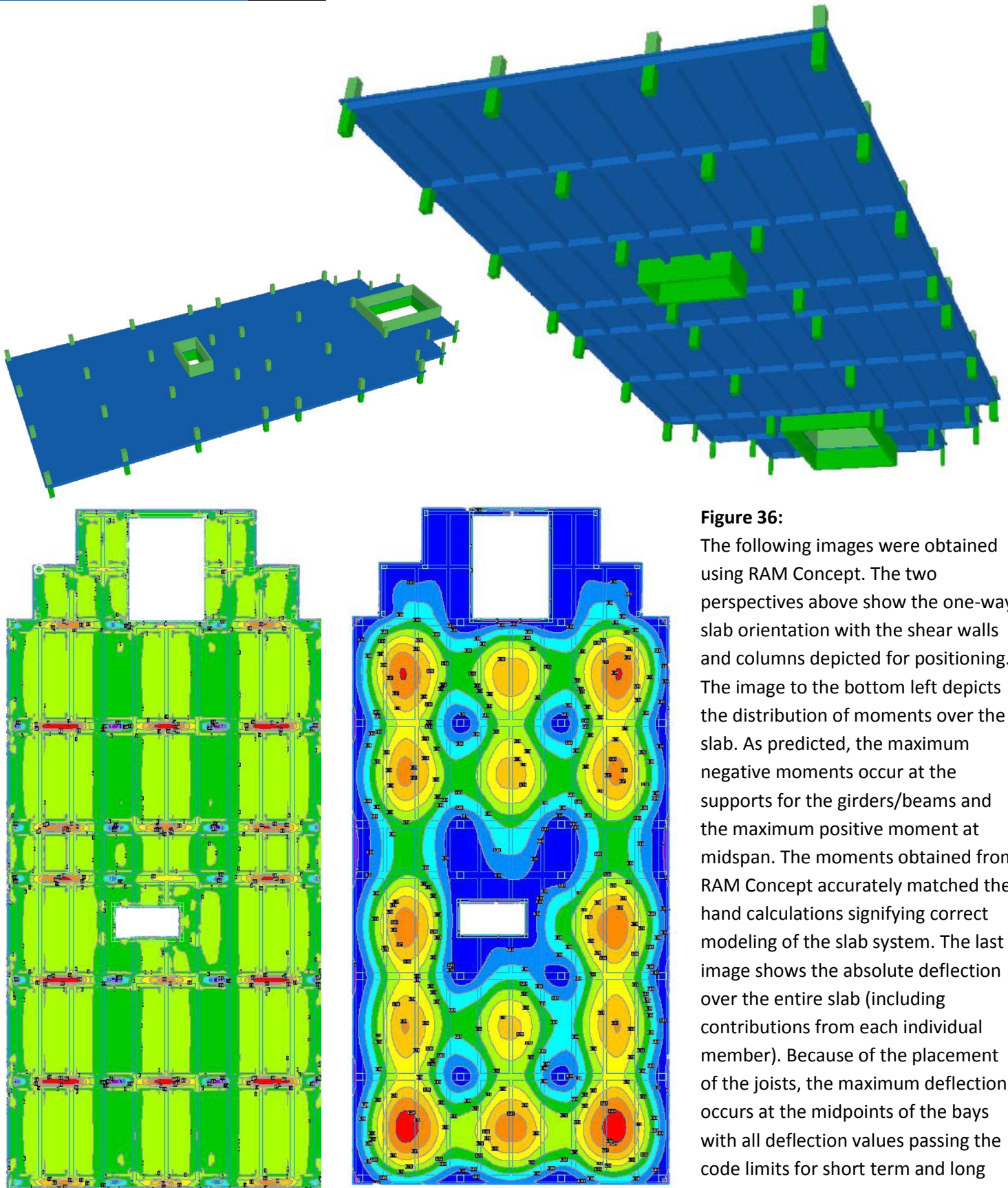

Figure 36:

The following images were obtained using RAM Concept. The two perspectives above show the one-way slab orientation with the shear walls and columns depicted for positioning. The image to the bottom left depicts the distribution of moments over the slab. As predicted, the maximum negative moments occur at the supports for the girders/beams and the maximum positive moment at midspan. The moments obtained from RAM Concept accurately matched the hand calculations signifying correct modeling of the slab system. The last image shows the absolute deflection over the entire slab (including contributions from each individual member). Because of the placement of the joists, the maximum deflection occurs at the midpoints of the bays with all deflection values passing the code limits for short term and long term load duration.

Alterations to Structure:

Beyond the modification of the slab system, slight changes were made to the building structure to allow the highest stiffness possible since base isolation becomes much more efficient as the stiffness of the non-isolated structure increases. The alterations included closing off the northern elevator core so that the entire perimeter is a shear wall. The reason behind only three shear walls surrounding the elevator shaft was due to the fact that the connected hospital building also used the elevator as a means for transportation and required access. However, with the move to Sacramento, it will be assumed that the building will not connect to an existing structure and therefore, the addition of a shear wall to the northern core can be accomplished.

Furthermore, in order to obtain the maximum number of moment frames in the X-Direction, two columns were inserted directly underneath the northern elevator core (Column lines B-3 and B-4). By having these two columns placed on each floor plan, every floor gains two more moment frames to combat the torsional effects seen by each floor. The structural alterations mentioned above are depicted in Figure 37 below for clarity (alterations highlighted in red).

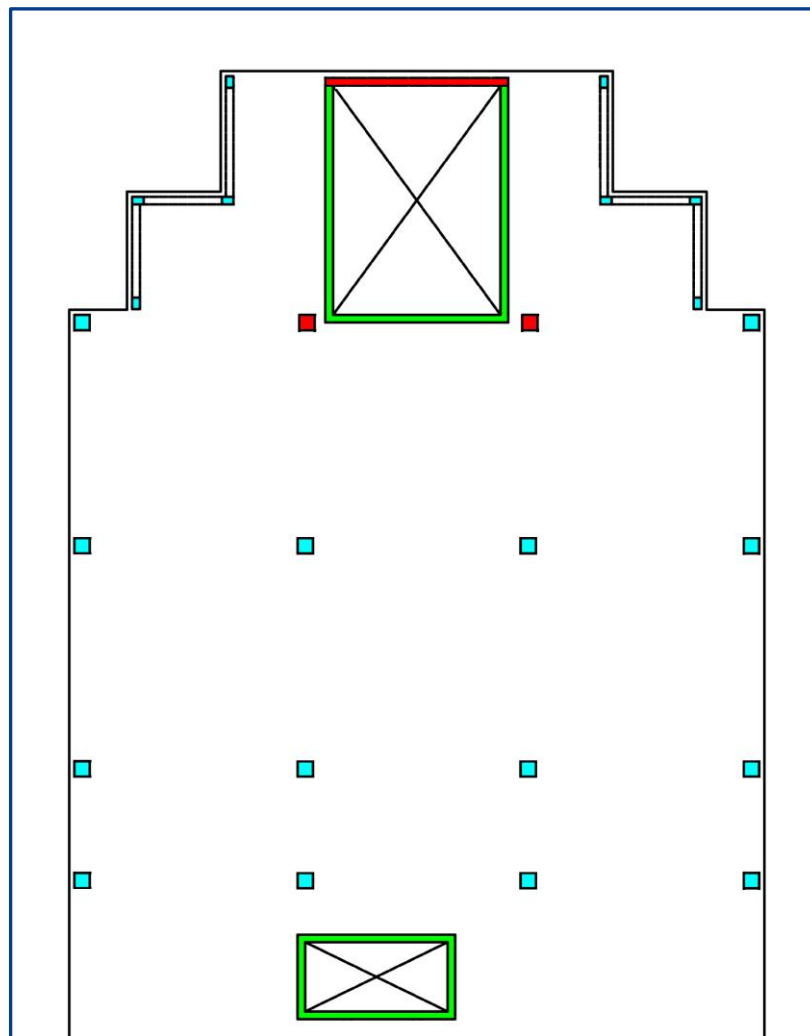

Figure 37:
Addition of two columns
and one shear wall to
original layout
(highlighted in red)

California Site Overview:

A geotechnical report was found for the area surrounding the University of California – Davis near Sacramento. It was assumed that the geotechnical report held true for the campus and the location of interest. Figure 38 below shows the location of the site (University of California – Davis) and the approximate footprint of the South Patient Tower on the site. As can be seen, the site is large enough to incorporate the footprint of the building. The orientation of the building remains the same with the elevator core towards the north with the building extending southwards.

Inspection of the geotechnical report of the Sacramento, California site revealed that the site was Class D. This is similar to the existing structure located in Virginia and this is the most crucial factor used from the report for the design of the structure for the new seismic loading. The below grade conditions of the site were similar to the current location and therefore will not produce a huge impact on foundation. One slight difference between the two sites is that the California location has slightly better soil characteristics. However, the soil characteristics do not vary that significantly when compared to the Virginia location. This slight change could warrant the usage of a swallow foundation, but since the soil differences were almost negligible, a study of the foundation system was not conducted for this report. However, since the below grade conditions does not diverge greatly from the existing conditions, the current foundation system of piles and pile caps is adequate for the design and relocation to Sacramento, California.

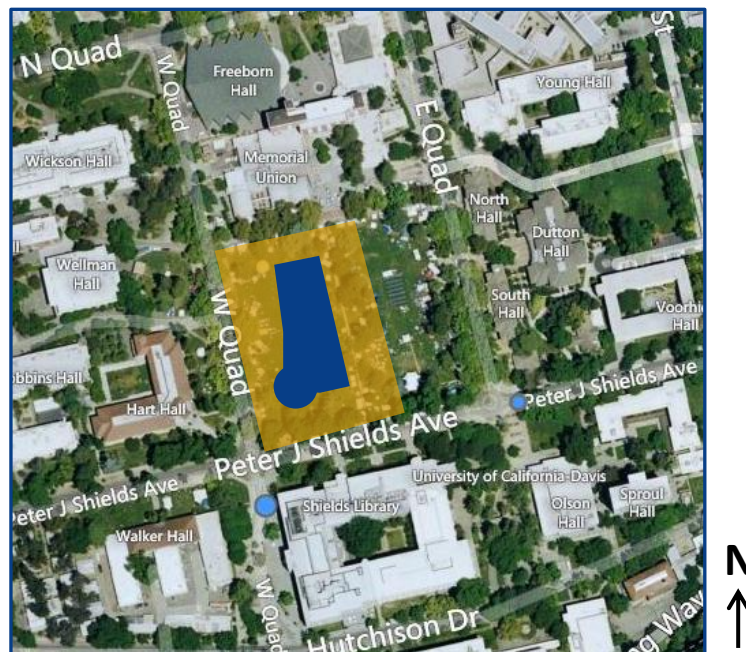

Figure 38:

Image from Bing Maps showing site selected on University of California's (Davis campus) campus. The approximate footprint of the SPT is shown in blue with the overall site highlighted in orange

Wind Load Calculations:

The calculation of the wind loads for the Falls Church, Virginia used a wind speed of 90 mph. However, due to the relocation, the design wind velocities change slightly. According to ASCE 7-05 (Chapter 6), the design wind velocity for Sacramento, California is 85 mph. The “Wind Loads” subsection underneath the “Lateral Loads” section discusses the simplifications and assumptions made to the overall shape of the structure. The full set of parameters used for the calculation of the wind forces for Sacramento, California can be found in Appendix B.

The wind pressures in both the N-S and E-W directions are listed in the figures below (Figures 39 and 40). The wind pressures were then evaluated into forces for each of the directions of interest (Figures depicting the story forces can be seen on the following pages). The resulting base shear in the N-S direction was found to be 201 kips and 416 kips in the E-W direction. In order to be able to make the comparison of the wind forces and seismic forces, the wind loads must be factored by 1.6 to account for the controlling load combinations. Once factored, the base shear in the N-S direction becomes 322 kips where the E-W directions forces are increased to 666 kips. The factored wind loads were then compared to the seismic loads for the design of the lateral system to verify the controlling load combination.

Wind Pressures N-S Direction							
Wall Type	Floor	Distances (ft)	Wind Pressures (psf)	Internal Pressure (psf)		Net Pressure (psf)	
				(+)(GC _{pi})	(-)(GC _{pi})	(+)(GC _{pi})	(-)(GC _{pi})
36' - 145'							
Windward Walls	Penthouse	145	14.0	3.58	-3.58	10.4	17.6
	11th	129.5	13.5	3.58	-3.58	10.0	17.1
	10th	118.17	13.2	3.58	-3.58	9.6	16.8
	9th	106.83	12.8	3.58	-3.58	9.2	16.4
	8th	95.5	12.4	3.58	-3.58	8.8	16.0
	7th	84.17	12.0	3.58	-3.58	8.4	15.6
	6th	72.93	11.5	3.58	-3.58	7.9	15.1
	5th	58.67	10.7	3.58	-3.58	7.2	14.3
4th	47.5	10.1	3.58	-3.58	6.6	13.7	
Leeward Walls	N/A	All	-5.1	3.58	-3.58	-8.7	-1.5
Side Walls	N/A	All	-12.2	3.58	-3.58	-15.8	-8.7
0' - 36'							
Windward Walls	3rd	36.17	9.38	3.58	-3.58	5.8	13.0
	2nd	24.83	8.38	3.58	-3.58	4.8	12.0
	1st	10.83	7.25	3.58	-3.58	3.7	10.8
	Ground	0	7.25	3.58	-3.58	3.7	10.8
Leeward Walls	N/A	All	-5.1	3.58	-3.58	-8.7	-1.6
Side Walls	N/A	All	-12.2	3.58	-3.58	-15.8	-8.7
Roof	N/A	0 - 72.5	-19.4	3.58	-3.58	-23.0	-15.8
	N/A	72.5 - 145	-13.9	3.58	-3.58	-17.5	-10.3
	N/A	145 - 290	-10.6	3.58	-3.58	-14.1	-7.0
	N/A	>290	-8.9	3.58	-3.58	-12.5	-5.3

Figure 39:

List of N-S direction wind pressures (California)

Wind Pressures E-W Direction							
Wall Type	Floor	Distances (ft)	Wind Pressures (psf)	Internal Pressure (psf)		Net Pressure (psf)	
				(+)(GC _{pi})	(-)(GC _{pi})	(+)(GC _{pi})	(-)(GC _{pi})
36' - 145'							
Windward Walls	Penthouse	145	13.4	3.58	-3.58	9.8	17.0
	11th	129.5	13.0	3.58	-3.58	9.4	16.6
	10th	118.17	12.6	3.58	-3.58	9.1	16.2
	9th	106.83	12.3	3.58	-3.58	8.7	15.9
	8th	95.5	11.9	3.58	-3.58	8.3	15.5
	7th	84.17	11.5	3.58	-3.58	7.9	15.1
	6th	72.93	11.0	3.58	-3.58	7.4	14.6
	5th	58.67	10.3	3.58	-3.58	6.7	13.9
4th	47.5	9.7	3.58	-3.58	6.2	13.3	
Leeward Walls	N/A	All	-8.4	3.58	-3.58	-12.0	-4.8
Side Walls	N/A	All	-11.7	3.58	-3.58	-15.3	-8.2
0' - 36'							
Windward Walls	3rd	36.17	9.0	3.58	-3.58	5.4	12.6
	2nd	24.83	8.0	3.58	-3.58	4.5	11.6
	1st	10.83	7.0	3.58	-3.58	3.4	10.5
	Ground	0	7.0	3.58	-3.58	3.4	10.5
Leeward Walls	N/A	All	-8.4	3.58	-3.58	-12.0	-4.8
Side Walls	N/A	All	-11.7	3.58	-3.58	-15.3	-8.2
Roof	0 - 72.5	0 - 72.5	-17.5	3.58	-3.58	-21.0	-13.9
	72.5 - 145	72.5 - 145	-17.5	3.58	-3.58	-21.0	-13.9
	145 - 290	145 - 290	-11.7	3.58	-3.58	-15.3	-8.2
	>290	>290	-11.7	3.58	-3.58	-15.3	-8.2

Figure 40:
List of N-W direction wind pressures (California)

Wind Forces N-S Direction									
Floor Level	Elevation (ft)	Tributary Below		Tributary Above		Story Force (k)	Story Shear (k)	Overturning Moment (ft-k)	Factored Force (k)
		Height (ft)	Area (ft ²)	Height (ft)	Area (ft ²)				
Penthouse	145	7.75	698	0	0	12.3	12.3	1778	19.6
11th	129.5	5.67	510	7.75	698	21.0	33.2	2718	33.6
10th	118.17	5.67	510	5.67	510	17.3	50.5	2042	27.6
9th	106.83	5.67	510	5.67	510	16.9	67.4	1806	27.1
8th	95.5	5.67	510	5.67	510	16.5	84.0	1578	26.4
7th	84.17	5.62	506	5.67	510	16.0	100.0	1350	25.7
6th	72.93	7.13	642	5.62	506	17.5	117.5	1279	28.1
5th	58.67	5.59	503	7.13	642	16.9	134.4	989	27.0
4th	47.5	5.67	510	5.59	503	14.2	148.6	675	22.7
3rd	36.17	5.67	595	5.67	510	14.7	163.3	532	23.5
2nd	24.83	7.00	735	5.67	595	16.5	179.8	410	26.4
1st	10.83	5.42	569	7.00	735	15.0	194.8	162	23.9
Ground	0	0	0	5.42	569	6.2	200.9	0	9.9
Total Base Shear =						200.9			321.5
						Total Overturning Moment =	15,318 ft-k	24,508 ft-k	

Figure 41:
List of N-S direction wind forces (California)

Wind Forces E-W Direction									
Floor Level	Elevation (ft)	Tributary Below		Tributary Above		Story Force (k)	Story Shear (k)	Overturning Moment (ft-k)	Factored Force (k)
		Height (ft)	Area (ft ²)	Height (ft)	Area (ft ²)				
Penthouse	145	7.75	1478	0	0	25.1	25.1	3645	40.2
11th	129.5	5.67	1081	7.75	1478	43.0	68.2	5573	68.9
10th	118.17	5.67	1082	5.67	1081	35.4	103.6	4187	56.7
9th	106.83	5.67	1081	5.67	1082	34.7	138.3	3706	55.5
8th	95.5	5.67	1081	5.67	1081	33.9	172.2	3237	54.2
7th	84.17	5.62	1072	5.67	1081	32.9	205.1	2770	52.7
6th	72.93	7.13	1360	5.62	1072	36.0	241.1	2626	57.6
5th	58.67	5.59	1065	7.13	1360	34.6	275.7	2032	55.4
4th	47.5	5.67	1081	5.59	1065	29.2	304.9	1386	46.7
3rd	36.17	5.67	1310	5.67	1081	30.9	335.8	1116	49.4
2nd	24.83	7.00	1617	5.67	1310	35.3	371.0	875	56.4
1st	10.83	5.42	1251	7.00	1617	32.0	403.0	346	51.1
Ground	0	0	0	5.42	1251	13.2	416.2	0	21.1
Total Base Shear =						416.2	Total Overturning Moment =		665.9
							31,1500 ft-k		50,399 ft-k

Figure 42:

List of E-W direction wind forces (California)

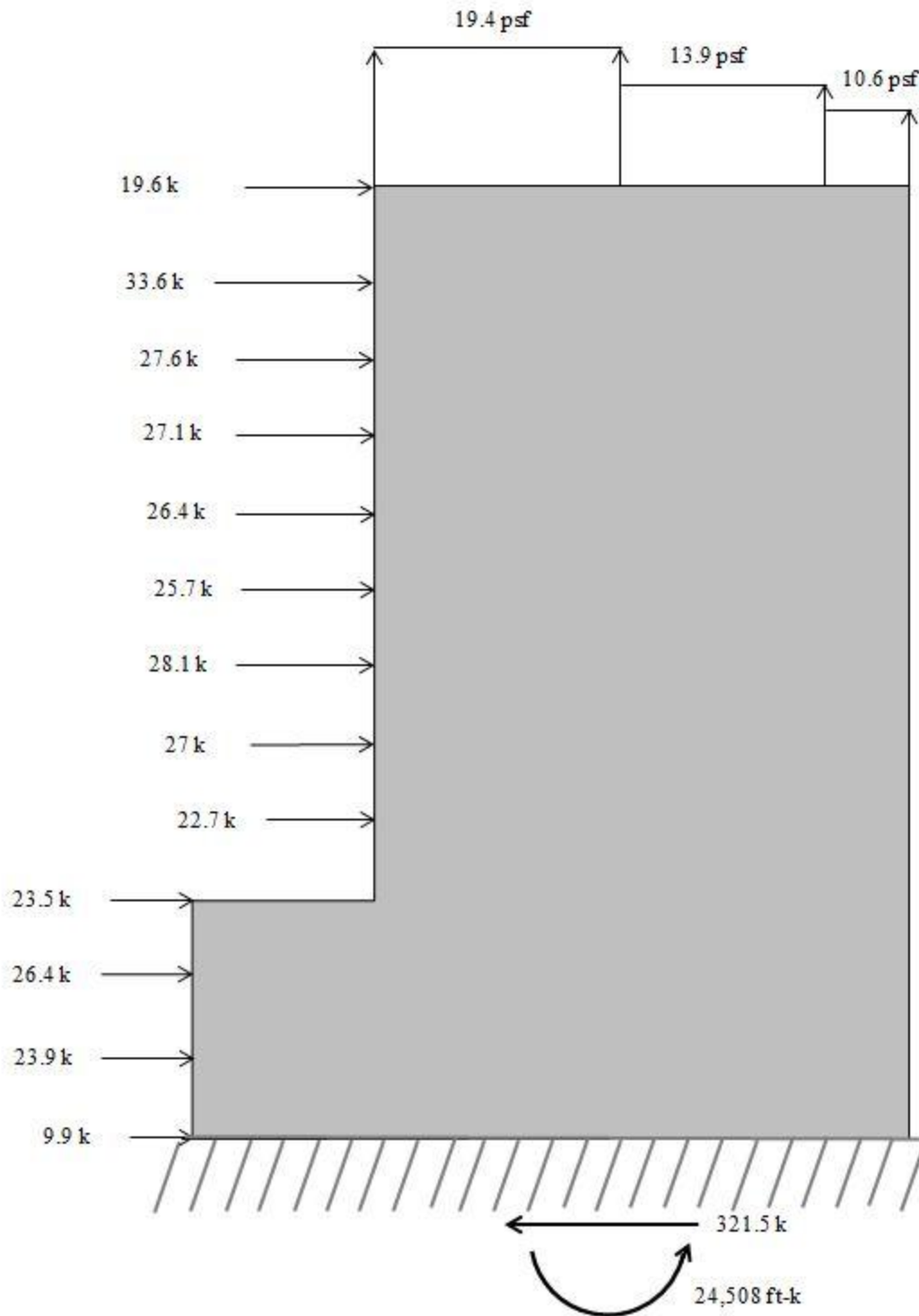

Figure 43:
 Diagram of N-S direction wind forces (California)
 *Story forces include 1.6 W Factor as well as
 the Leeward wall pressures

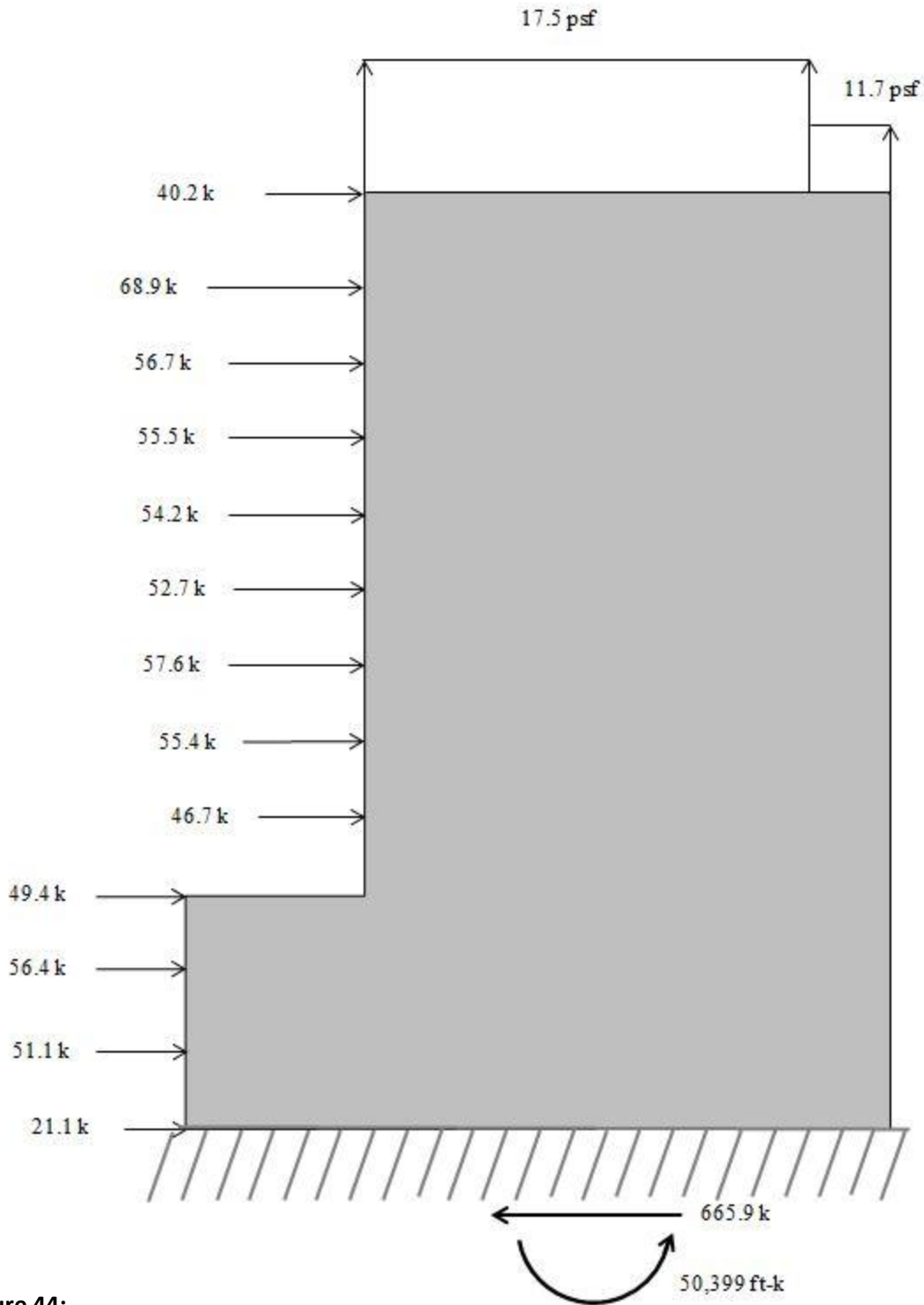

Figure 44:
 Diagram of E-W direction wind forces (California)
 *Story forces include 1.6 W Factor as well as
 the Leeward wall pressures

Seismic Load Calculations:

It was assumed that the design of the various systems would be controlled by seismic forces, and therefore seismic forces had to be calculated for Sacramento, California. Since the forces are dependent upon the weight of the structure, the seismic forces first had to be calculated using a base model. This model was created by using the one-way slab design with moment frames and a fixed base structure (CA-Base Model). The CA-Base Model, with the additional shear wall and columns as mentioned in the alteration section, will be the basis for comparison for the remaining portion of this report. The weight of the structure was first found and is summarized in Figure 45.

Weight Per Level		
Level	Area (ft ²)	Weight (kips)
Ground	25513	N/A
1st	25513	3855
2nd	11649	2732
3rd	17958	3186
4th	16571	2911
5th	16571	3013
6th	16571	3013
7th	16571	2911
8th	16571	2911
9th	16571	2911
10th	16571	2911
11th	16571	2999
Penthouse/Roof	16571	3831
		37184

Figure 45:
Summary of floor weights

The complete weight breakdown and parameters for the California site can be found in Appendix C. The Equivalent Lateral Force Procedure (ELF) was used to calculate the base shears. Before completing the ELF Procedure, the selection of the Response Modification Coefficient was necessary in order to fully perform the calculations (discussion in the next paragraph). Upon completion of the ELF Procedure, the base shear was found to be approximately 2,384 kips. When compared to the structure located in Virginia, the base shear experienced roughly a 320% increase. Also, when compared to the wind calculations, as expected the seismic base shear far exceeds the wind forces by 358%.

The original system utilized a Response Modification Coefficient factor of 4.5. The following figure (see Figure 46) taken from ASCE 7-05 *Minimum Design Loads for Buildings and Other Structures* uses the title “Shear Wall-Frame Interactive System with Ordinary Reinforced Concrete Moment Frames and Ordinary Reinforced Concrete Shear Walls” to describe the existing system. However, this system is not permitted

to be used for Seismic Design Category D (the SDC for the California Location, see Appendix C for detailed calculations). Therefore, a new Response Modification Coefficient had to be used in place of the one used for the existing structure.

Seismic Force-Resisting System	ASCE 7 Section where Detailing Requirements are Specified	Response Modification Coefficient, R^a	System Overstrength Factor, Ω_0^b	Deflection Amplification Factor, C_d^b	Structural System Limitations and Building Height (ft) Limit ^c				
					Seismic Design Category				
					B	C	D ^d	E ^d	F ^e
E. DUAL SYSTEMS WITH INTERMEDIATE MOMENT FRAMES CAPABLE OF RESISTING AT LEAST 25% OF PRESCRIBED SEISMIC FORCES	12.2.5.1								
1. Special steel concentrically braced frames ^f	14.1	6	2½	5	NL	NL	35	NP	NP ^{h,k}
2. Special reinforced concrete shear walls	14.2	6½	2½	5	NL	NL	160	100	100
3. Ordinary reinforced masonry shear walls	14.4	3	3	2½	NL	160	NP	NP	NP
4. Intermediate reinforced masonry shear walls	14.4	3½	3	3	NL	NL	NP	NP	NP
5. Composite steel and concrete concentrically braced frames	14.3	5½	2½	4½	NL	NL	160	100	NP
6. Ordinary composite braced frames	14.3	3½	2½	3	NL	NL	NP	NP	NP
7. Ordinary composite reinforced concrete shear walls with steel elements	14.3	5	3	4½	NL	NL	NP	NP	NP
8. Ordinary reinforced concrete shear walls	14.2	5½	2½	4½	NL	NL	NP	NP	NP
F. SHEAR WALL-FRAME INTERACTIVE SYSTEM WITH ORDINARY REINFORCED CONCRETE MOMENT FRAMES AND ORDINARY REINFORCED CONCRETE SHEAR WALLS	12.2.5.10 and 14.2	4½	2½	4	NL	NP	NP	NP	NP
G. CANTILEVERED COLUMN SYSTEMS DETAILED TO CONFORM TO THE REQUIREMENTS FOR:	12.2.5.2								
1. Special steel moment frames	12.2.5.5 and 14.1	2½	1¼	2½	35	35	35	35	35
2. Intermediate steel moment frames	14.1	1½	1¼	1½	35	35	35 ^h	NP ^{h,i}	NP ^{h,i}
3. Ordinary steel moment frames	14.1	1¼	1¼	1¼	35	35	NP	NP ^{h,i}	NP ^{h,i}
4. Special reinforced concrete moment frames	12.2.5.5 and 14.2	2½	1¼	2½	35	35	35	35	35
5. Intermediate concrete moment frames	14.2	1½	1¼	1½	35	35	NP	NP	NP
6. Ordinary concrete moment frames	14.2	1	1¼	1	35	NP	NP	NP	NP
7. Timber frames	14.5	1½	1½	1½	35	35	35	NP	NP
H. STEEL SYSTEMS NOT SPECIFICALLY DETAILED FOR SEISMIC RESISTANCE, EXCLUDING CANTILEVER COLUMN SYSTEMS	14.1	3	3	3	NL	NL	NP	NP	NP

Figure 46:
Response Modification Coefficient table (not fully shown) taken from ASCE 7-05

Before the selection of the new R value, the relative stiffness of each floor had to be accounted for in order to properly use the ASCE 7-05 Response Modification Coefficient table. To calculate the relative stiffness of each member participating in the later force resisting system, a “dummy” force was applied to the center of rigidity for the specific floor in question. Then, the story forces were found using ETABS in each of the members supporting the specific floor of interest. The purpose for applying the load at the center of rigidity stems from the basic understanding of how wind and earthquake forces are applied to

the structure. Both of these types of forces are act at the center of mass while the structure resists the forces through the center of rigidity. If the center of mass and center of rigidity do not line up exactly, torsion will then be introduced into the system and torsional shears will be present in all of the members resisting the lateral forces. The idea behind applying the “dummy” forces at the center of rigidity is based on the above information. Due to the large eccentricities found for each floor, if the force were applied to the center of mass the members not in the direction of interest will experience shear values (torsional) and take some of the forces. Therefore, by applying the “dummy” forces at the center of rigidity, the torsional aspect of the building is almost negligible and the lateral force resisting members in the direction of interest will take the majority of the force and the relative stiffness of each member can then be calculated. In the following figures below, the relative stiffness for a typical floor is shown for both the X and Y-Directions. A floor plan is also shown (see Figure 48 on the following page for the frame ID’s).

X-Direction (Typical Floor Plan) : 1000k Load at COR		
ID	Total Shear	%
SW5	231	23%
SW6	173	17%
SW7	100	10%
SW8	63	6%
FR7	49	5%
FR8	65	6%
FR9	64	6%
FR10	63	6%
FR11	62	6%
FR12	61	6%
FR13	60	6%
FR14	10	1%
$\Sigma V =$		1001
		$\Sigma V_{SW} =$ 57%
		$\Sigma V_{Frames} =$ 43%

Y-Direction (Typical Floor Plan) : 1000k Load at COR		
ID	Total Shear	%
SW1	324	33%
SW2	318	33%
SW3	38	4%
SW4	43	4%
FR1	6	1%
FR2	6	1%
FR3	6	1%
FR4	6	1%
FR5	113	12%
FR6	113	12%
$\Sigma V =$		973
		$\Sigma V_{SW} =$ 74%
		$\Sigma V_{Frames} =$ 26%

Figure 47:
Relative stiffness of the lateral force resisting members in both the X and Y-Direction

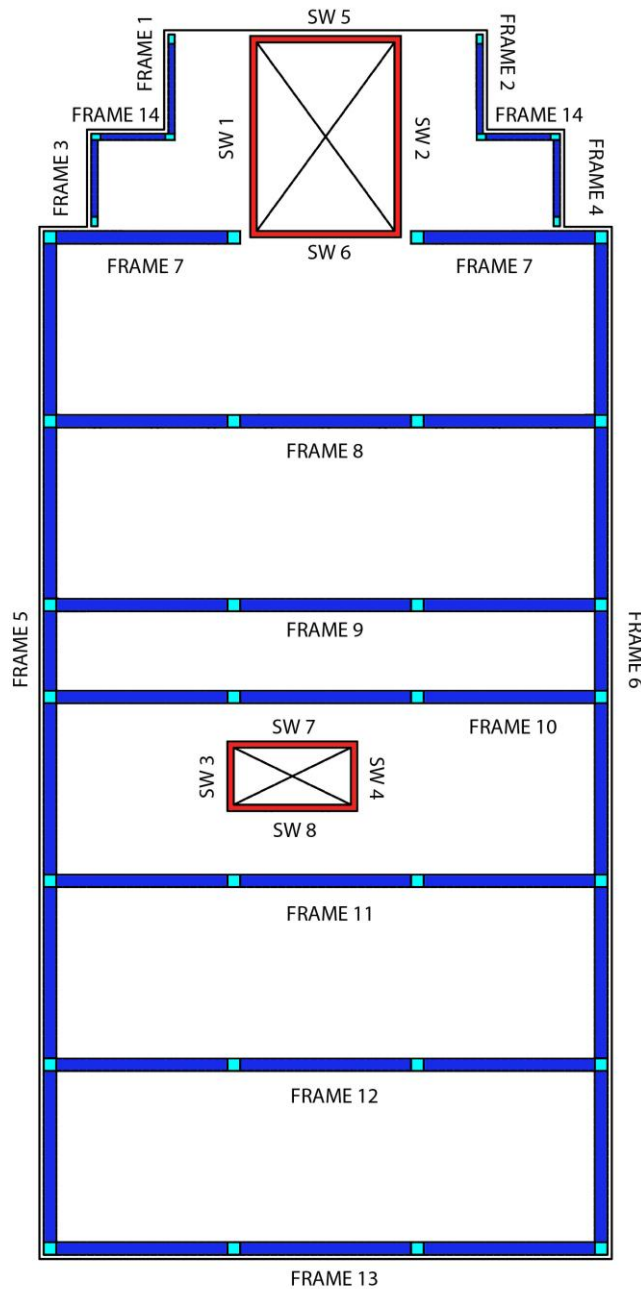

Figure 48:
Frame and shear wall ID tags

Based on the information presented in the tables on the previous page, the shear walls take roughly 54% and 74% in the X and Y-Direction respectively, while the moment frames take the remaining portion of the shear. Since the moment frames take at least 25% of the forces in each direction, the “Dual Systems with Intermediate Moment Frames Capable of Resisting at Least 25% of Prescribed Seismic Forces” can be utilized. This ultimately helped the overall performance of the structure by increasing the R value of the structural system. As can be seen in Figure 49, the only subsection of the group that was adequate for SDC D and the structure at hand consists of the intermediate moment frames with special

reinforced concrete shear walls ($R = 6.5$; $C_d = 5$).

E. DUAL SYSTEMS WITH INTERMEDIATE MOMENT FRAMES CAPABLE OF RESISTING AT LEAST 25% OF PRESCRIBED SEISMIC FORCES	12.2.5.1									
1. Special steel concentrically braced frames ^f	14.1	6	2½	5	NL	NL	35	NP	NP ^{h,k}	
2. Special reinforced concrete shear walls	14.2	6½	2½	5	NL	NL	160	100	100	
3. Ordinary reinforced masonry shear walls	14.4	3	3	2½	NL	160	NP	NP	NP	
4. Intermediate reinforced masonry shear walls	14.4	3½	3	3	NL	NL	NP	NP	NP	
5. Composite steel and concrete concentrically braced frames	14.3	5½	2½	4½	NL	NL	160	100	NP	
6. Ordinary composite braced frames	14.3	3½	2½	3	NL	NL	NP	NP	NP	
7. Ordinary composite reinforced concrete shear walls with steel elements	14.3	5	3	4½	NL	NL	NP	NP	NP	
8. Ordinary reinforced concrete shear walls	14.2	5½	2½	4½	NL	NL	NP	NP	NP	

Figure 49:

Response Coefficients for Dual Systems with Intermediate Moment Frames (selection shown highlighted in red)

Using an R value of 6.5 implies that special detailing would need to be done in order to assure that the beams and columns part of intermediate moment frames are reinforced to meet the standards set forth in ACI 318-08. Due to time constraints, the detailing of the specific beams and columns to meet intermediate moment frame design criteria was not undertaken in this assignment. Similar to the moment frames, the shear walls fall under a category that requires special detailing. Unlike the moment frames, the shear walls require rigorous detailing and therefore were not detailed for this report. Upon the finding of an adequate R value to accurately model the structure at hand, the ELF Procedure was utilized to get base shear values for the system. However, due to the Seismic Design Category (D) and the horizontal irregularities associated with the structure, ASCE 7-05 prevents the use of the ELF procedure. Instead, the Modal Response Spectrum Analysis (MRSA) or a Time History Analysis can be conducted. For the fixed structure, the MRSA method was undertaken and used to design the members for the performance requirements.

The forces produced from the ELF procedure are an important calculation for the other two methods because the values form the baseline. The use of the other two methods can result, and typically does, in lower base shear values. Therefore, the first step in the process is solving for the base shear values using the ELF procedure, which can be seen in Figure 50. Following the analysis using ELF procedure, utilizing the MRSA procedure resulted in a smaller base shear. The actual value calculated using the MRSA was below the 85% limit set forth in ASCE 7-05. Therefore, the C_s value from the MRSA method had to be limited to $0.85C_{s,ELF}$. Figure 51 lists the story force values and the overall base shear when using the Modal Response Spectrum Analysis. Sample calculations for this particular method are shown on pages 52 and 53 with a list of the formulas used throughout the procedure.

Seismic Forces N-S and E-W Direction (California - ELF)							
Level	Story Weight, w_x (k)	Story Height, h_x (ft)	$w_x h_x^k$	C_{vx}	Story Force (k)	Story Shear (k)	Overturning Moment (k-ft)
Penthouse/Roof	3831	145	2942673	0.222	530	530	76811
11th	2999	129.33	1977094	0.149	356	886	46030
10th	2911	118	1698241	0.128	306	1191	36074
9th	2911	106.67	1484135	0.112	267	1459	28499
8th	2911	95.33	1277346	0.096	230	1688	21921
7th	2911	84	1078823	0.081	194	1883	16313
6th	3013	72.67	920319	0.070	166	2048	12039
5th	3013	58.67	691616	0.052	125	2173	7305
4th	2911	47.33	501586	0.038	90	2263	4274
3rd	3186	36	380967	0.029	69	2332	2469
2nd	2732	24.67	197259	0.015	36	2367	876
1st	3855	10.67	90907	0.007	16	2384	175
Ground	N/A	0	0	0	0	2384	0
Base Shear =						2384 k	
Total Overturning Moment =							252,785 k-ft

Figure 50:

List of seismic forces for both directions (California – ELF)

Seismic Forces N-S and E-W Direction (California - MRSA)							
Level	Story Weight, w_x (k)	Story Height, h_x (ft)	$w_x h_x^k$	C_{vx}	Story Force (k)	Story Shear (k)	Overturning Moment (k-ft)
Penthouse/Roof	3831	145	2942673	0.222	450	450	65289
11th	2999	129.33	1977094	0.149	303	753	39125
10th	2911	118	1698241	0.128	260	1013	30663
9th	2911	106.67	1484135	0.112	227	1240	24224
8th	2911	95.33	1277346	0.096	195	1435	18632
7th	2911	84	1078823	0.081	165	1600	13866
6th	3013	72.67	920319	0.070	141	1741	10234
5th	3013	58.67	691616	0.052	106	1847	6209
4th	2911	47.33	501586	0.038	77	1924	3633
3rd	3186	36	380967	0.029	58	1982	2099
2nd	2732	24.67	197259	0.015	30	2012	745
1st	3855	10.67	90907	0.007	14	2026	148
Ground	N/A	0	0	0	0	2026	0
Base Shear =						2026 k	
Total Overturning Moment =							214,867 k-ft

Figure 51:

List of seismic forces for both directions (California – MRSA)

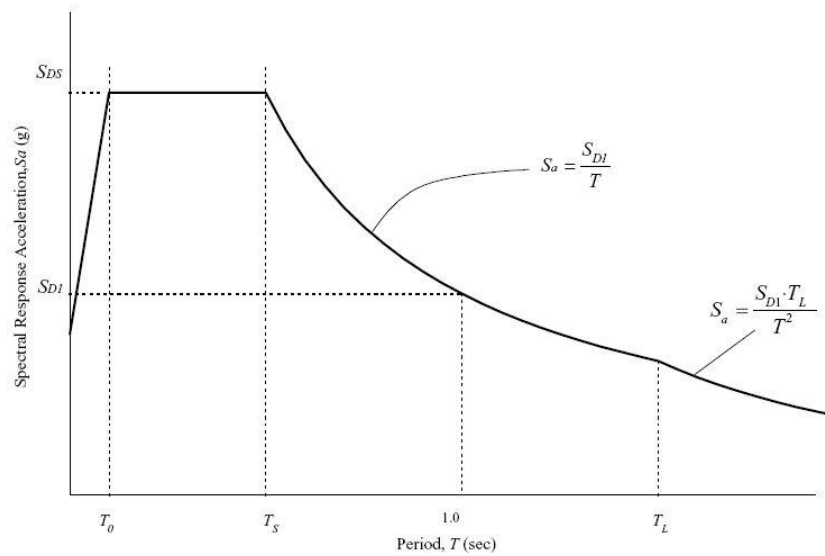

Figure 52:
Design Response Spectrum taken from ASCE 7-05

The following formulas were taken from ASCE 7-05 §11.4.5

For $T < T_0$:

$$S_a = S_{DS} \left(0.4 + 0.6 \frac{T}{T_0} \right)$$

For $T_0 \leq T \leq T_s$:

$$S_a = S_{DS}$$

For $T_s \leq T \leq T_L$:

$$S_a = \frac{S_{D1}}{T}$$

For $T < T_L$:

$$S_a = \frac{S_{D1} T_L}{T^2}$$

$$T_0 = 0.2 \frac{S_{D1}}{S_{DS}}$$

$$T_s = \frac{S_{D1}}{S_{DS}}$$

$T_0 =$	0.108 sec.
$T_s =$	0.542 sec.
$T_L =$	8 sec.

CA - Base Model: Modal Information							
Mode	Period	UX%	UY%	S _a	S _a /(R/I)	(C _{m,i} *UX%) ²	(C _{m,i} *UY%) ²
1	1.94	62.03	0.00	0.17	0.04	5.7E-04	3.3E-13
2	1.68	0.00	65.24	0.19	0.04	4.8E-12	8.5E-04
3	1.03	3.88	0.01	0.31	0.07	8.0E-06	9.2E-11
4	0.50	13.23	0.02	0.60	0.14	3.4E-04	9.6E-10
5	0.37	0.01	20.16	0.60	0.14	2.3E-10	7.8E-04
6	0.25	1.74	0.00	0.60	0.14	5.8E-06	3.5E-11
7	0.23	7.57	0.00	0.60	0.14	1.1E-04	1.9E-14
8	0.17	0.00	5.45	0.60	0.14	0.0E+00	5.7E-05
9	0.14	1.13	0.00	0.60	0.14	2.4E-06	6.9E-13
10	0.12	3.28	0.01	0.60	0.14	2.1E-05	2.2E-10
11	N/A	N/A	N/A	N/A	N/A	N/A	N/A
12	N/A	N/A	N/A	N/A	N/A	N/A	N/A
Σ =		92.8802	90.9074				

Figure 53: MRSA values obtained

$$C_{m,x} = \sqrt{\Sigma((c_{m,i} * UX\%)^2)} = 0.032$$

$$C_{m,y} = \sqrt{\Sigma((c_{m,i} * UY\%)^2)} = 0.041$$

C _S ELF =	0.064
85%*C _S =	0.054
∴ C _S =	0.054

(Since both C_{m,x} and C_{m,y} are > 0.85%C_S)

The key concept behind the Modal Response Spectrum Analysis is that the designer only needs to include 90% of the total mass of the building. Although 12 modes were calculated using ETABS, only 10 modes were needed before each direction incorporated at least 90% of the building mass. By only using 12 modes, a decrease in base shears can be observed, ultimately using the 85% cutoff. Using the new C_S values results in story forces and base shear tabulated in Figure 51. Before moving onto the design of the fixed base

Center of Mass/Rigidity for 12" Shear Walls and 24x24" Moment Frames						
Level	COM _x	COM _y	COR _x	COR _y	e _x	e _y
Penthouse/Roof	79.5	130.9	78.9	161.4	0.5	30.4
11 th	79.5	130.9	78.8	163.1	0.6	32.2
10 th	79.5	130.9	78.7	164.8	0.7	33.9
9 th	79.5	130.9	78.6	166.7	0.9	35.8
8 th	79.5	130.9	78.5	168.7	1.0	37.8
7 th	79.5	130.9	78.4	170.6	1.1	39.7
6 th	79.5	130.9	78.3	172.3	1.2	41.4
5 th	79.5	130.9	79.1	173.9	0.4	43.0
4 th	79.5	130.9	79.0	175.0	0.4	44.1
3 rd	78.2	129.0	78.8	175.7	0.6	46.6
2 nd	78.4	131.7	78.4	175.0	0.0	43.4
1 st	77.4	130.6	77.2	170.1	0.3	39.5
* All dimensions are in ft						

Figure 54: Center of Mass/Rigidity and eccentricities for the X and Y-Directions

structure, the base model was checked for torsional irregularities. As previously mentioned, the ELF procedure was not permitted for the structure in Sacramento, California due to the combination of the SDC and the torsional irregularity. To support the assumption of torsional irregularities, the following figures run through the calculations for the torsional effects. As can be seen in Figure 54, the center of mass and center of rigidity differ slightly in the X-Direction (negligible); however, in the Y-Direction the eccentricity becomes quite large. The first step in solving for the type of horizontal irregularity involved using the deflection along a transverse line and an $A_x = 1.0$ and relate them using the following equations (results displayed in Figure 55):

$$A_{xx} = \left[\frac{\delta_{max}}{1.2\delta_{avg}} \right]^2$$

$$\delta_{avg} = \frac{\delta_A + \delta_B}{2}$$

One-Way Slab with Moment Frames				
	Level	δ_A	δ_B	A_{xx}
X-Direction Loading	Penthouse/Roof	4.87	2.44	1.23
	11th	4.37	2.10	1.27
	10th	3.98	1.85	1.29
	9th	3.56	1.60	1.32
	8th	3.12	1.36	1.35
	7th	2.67	1.12	1.38
	6th	2.21	0.89	1.41
	5th	1.63	0.62	1.46
	4th	1.18	0.43	1.50
	3rd	0.91	0.16	1.99
	2nd	0.49	0.08	2.05
	1st	0.12	0.02	2.10
	Ground	N/A	N/A	N/A
	Level	δ_A	δ_B	A_{xy}
Y-Direction Loading	Penthouse/Roof*	2.75	2.75	1.00
	11th*	2.40	2.40	1.00
	10th*	2.13	2.13	1.00
	9th*	1.87	1.87	1.00
	8th*	1.60	1.60	1.00
	7th*	1.33	1.33	1.00
	6th*	1.07	1.07	1.00
	5th*	0.77	0.77	1.00
	4th*	0.55	0.55	1.00
	3rd*	0.35	0.35	1.00
	2nd*	0.23	0.19	1.00
	1st*	0.05	0.05	1.00
	Ground*	N/A	N/A	N/A

* A_x value of 1.0 used since calculated value < 1.0

Figure 55:
Amplification factors used to calculate torsional effects

The results of the amplification check show a striking difference between the existing structure and the redesigned system. For the existing structure, the A_x values were close to the 3.0 maximum value for each floor (some floors had values above the maximum allowable), whereas the redesigned system experiences lower amplification factors for the building as a whole. Once finding the amplifications for each story level and direction of loading, the accidental moments (5% of the dimension in question) were amplified using the A_x values. The following two charts contain the information regarding the forces, displacements, story drifts and the results to the torsional irregularity check for the CA – Base Model.

One-Way Slab with Moment Frames with Amplification Factor										
Earthquake Serviceability					Displacements				Story Drifts	
		Story Level	E (k)	M (ft-k)	δ_{XE}	δ_{YE}	$(C_d\delta_{XE})/l$	$(C_d\delta_{YE})/l$	Δ_X	Δ_Y
Case 1	1.0E _x + M _z	Penthouse/Roof	450	5301	5.00	0.71	16.67	2.37	1.71	0.16
		11th	303	3656	4.49	0.66	14.96	2.21	1.34	0.14
		10th	260	3206	4.09	0.62	13.63	2.07	1.41	0.16
		9th	227	2863	3.66	0.57	12.21	1.91	1.49	0.18
		8th	195	2519	3.22	0.52	10.72	1.73	1.56	0.21
		7th	165	2175	2.75	0.46	9.17	1.52	1.58	0.22
		6th	141	1900	2.27	0.39	7.58	1.30	1.99	0.33
		5th	106	1470	1.68	0.29	5.60	0.97	1.52	0.25
		4th	77	1096	1.22	0.22	4.08	0.72	1.39	0.23
		3rd	58	1341	0.81	0.15	2.69	0.49	1.15	0.20
		2nd	30	713	0.46	0.09	1.53	0.30	1.17	0.23
		1st	14	338	0.11	0.02	0.36	0.07	0.36	0.07
		Ground	0	0	0	0	0	0	0	
Case 2	1.0E _y + M _z	Penthouse/Roof	450	2026	0.22	2.75	0.72	9.18	0.06	1.18
		11th	303	1361	0.20	2.40	0.66	8.00	0.05	0.89
		10th	260	1169	0.18	2.13	0.62	7.12	0.05	0.90
		9th	227	1022	0.17	1.87	0.56	6.22	0.06	0.90
		8th	195	880	0.15	1.60	0.50	5.32	0.07	0.89
		7th	165	743	0.13	1.33	0.44	4.42	0.07	0.86
		6th	141	634	0.11	1.07	0.37	3.56	0.10	0.99
		5th	106	476	0.08	0.77	0.27	2.58	0.07	0.74
		4th	77	345	0.06	0.55	0.20	1.83	0.06	0.66
		3rd	58	306	0.04	0.35	0.13	1.18	0.05	0.48
		2nd	30	158	0.02	0.21	0.08	0.70	0.06	0.53
		1st	14	73	0.01	0.05	0.02	0.17	0.02	0.17
		Ground	0	0	0	0	0	0	0	

Figure 56:

Forces and moments (including amplification factors) used to calculate torsional effects.

Horizontal Irregularities						
Torsional Irregularity						Horizontal Irregularity
	Story Level	Δ_{max}	Δ_{trans}	$\Delta_{max}/\Delta_{avg}$		
Case 1	1.0E _x + M _{E_x}	Penthouse/Roof	1.71	1.11	1.21	Type 1a
		11th	1.34	0.82	1.24	Type 1a
		10th	1.41	0.82	1.27	Type 1a
		9th	1.49	0.81	1.30	Type 1a
		8th	1.56	0.79	1.33	Type 1a
		7th	1.58	0.75	1.35	Type 1a
		6th	1.99	0.87	1.39	Type 1a
		5th	1.52	0.62	1.42	Type 1b
		4th	1.39	0.54	1.44	Type 1b
		3rd	1.15	0.42	1.47	Type 1b
		2nd	1.17	0.34	1.55	Type 1b
		1st	0.36	0.10	1.55	Type 1b
	Ground	N/A	N/A	N/A	N/A	
	Story Level	Δ_{max}	Δ_{trans}	$\Delta_{max}/\Delta_{avg}$		
Case 2	1.0E _y + M _{E_y}	Penthouse/Roof	1.23	1.23	1.00	No Torsional Irregularity
		11th	0.93	0.93	1.00	
		10th	0.94	0.94	1.00	
		9th	0.94	0.94	1.00	
		8th	0.93	0.93	1.00	
		7th	0.90	0.90	1.00	
		6th	1.02	1.02	1.00	
		5th	0.77	0.77	1.00	
		4th	0.68	0.68	1.00	
		3rd	0.49	0.56	0.94	
		2nd	0.54	0.48	1.06	
		1st	0.17	0.17	1.00	
	Ground	N/A	N/A	N/A		

Figure 57:
Horizontal torsional irregularities for each story level and direction

As can be seen in Figure 57, the floors experience torsional irregularities in each level for X-Direction loading. Therefore, the building as a whole is considered torsionally irregular. When compared to the existing structure, the moment frames have a huge impact on the overall torsional effects. The existing structure experiences $\Delta_{max}/\Delta_{avg}$ values in the range on 2.0 to 2.5. On the other hand, the values associated with the redesigned structure are in the range of 1.2 to 1.55. The influence of the moment frames on the structure ultimately decreased the eccentricity value and lowers the torsional effects. With the existing structure, all of the floors were designated with the horizontal irregularity 1b while some floors of the redesign only had 1a. By delving into the torsional aspects of the structure, it is clear from the various models that the moment frames helped reduce the torsional effects from the eccentricity. One consequence for torsionally irregular buildings is the addition of ρ (redundancy factor = 1.3) for the strength design checks. Although foundations were not considered in this report, a sample calculation is in Appendix C to ensure no tensile forces were present (especially important for isolation systems).

Fixed Base Structure:

Once the CA – Base Model had been analyzed completely in terms of serviceability and strength conditions, the model was designed in order to meet certain performance requirements. The fixed base structure (CA – Fixed Model) was designed to meet S-3 (“Life Safety”) and S-1 (“Immediate Occupancy”) requirements as set forth in ASCE 41-06. According to code, S-3 requires an interstory drift value less than 1% of the story height for concrete moment walls and an S-1 drift less than 0.5% of the story height. For concrete frames, both the S-3 and S-1 performance requirements increase to 2% and 1% respectively. For this report, the structure was designed for both S-3 and S-1; however, due to the dual system in place with the structure, the ultimate goal was to meet S-3 and S-1 performance requirements pertaining to the more severe guidelines, the concrete shear walls. The CA – Fixed Model S-1 structure designed will serve as the controlling design and will later be compared to the same structure with base isolation. It was understood that numerous iterations would be needed to find the structure that passes the strict criteria of the “Immediate Occupancy” category. Modern buildings contain extremely sensitive and costly equipment, and in the case of the South Patient Tower, it will be necessary to be able to access the building immediately following a severe earthquake. Hospitals, communication and emergency centers must be operational when needed the most: directly following an earthquake event.

Heavily relying on ETABS, multiple scenarios were completed in order to find the combination of moment frames and shear walls. The first iteration included changing strictly the moment frames. The columns were assumed to remain the same size as the existing structure for the iteration process. The first iteration can be seen in Figure 58.

		Model With Moment Frames						Deflection Criteria Met?			
12" Shear Walls	Frame Size	Period	Maximum Drift X (in.)	Maximum Drift Y (in.)	S-3 Δ_a (1.0%)	S-1 Δ_a (0.5%)	S-3 _x	S-3 _y	S-1 _x	S-1 _y	
	24x24	1.944	1.650	1.316	1.84	0.92	Yes	Yes	No	No	
	24x28	1.786	1.292	1.199	1.84	0.92	Yes	Yes	No	No	
	24x32	1.651	1.038	1.093	1.84	0.92	Yes	Yes	No	No	
	24x36	1.537	0.859	1.001	1.84	0.92	Yes	Yes	Yes	No	

Figure 58:

First iteration with the same thickness shear walls as the existing structure

As can be seen in Figure 58, the structure was not able to successfully meet the S-1 performance requirements in each direction by keeping the same shear wall thickness as the original structure. The limit for the moment frames was considered 24 in. x 36 in. due to the ceiling plenum space limitations and a desire to keep the same floor to floor heights as the existing building. The next trial increased the shear walls by 2 in. and calculated the same moment frames as the previous trial selection. The second iteration can be seen on the following page (see Figure 59). Unlike the first iteration, this trial successfully produced a structure that met the drift limitations for the S-1 performance category. With 16 in. shear walls, the structure was able to produce interstory drift values below the 0.5% limit for both the X and Y-Directions. For each of the trials, the periods obtained from ETABS were inserted into the Modal Response Spectrum formulas to ensure that the 85% limit controlled. In each of the remaining cases, the structure met the “Immediate Occupancy” design category at varying sizes of moment

frames. For the most part, increasing the size of the shear walls aided the Y-Direction far more than the X-Direction.

Model With Moment Frames							Deflection Criteria Met?			
16" Shear Walls	Frame Size	Period	Maximum Drift X (in.)	Maximum Drift Y (in.)	S-3 Δ _a (1.0%)	S-1 Δ _a (0.5%)	S-3 _x	S-3 _y	S-1 _x	S-1 _y
	24x24	1.787	1.480	1.063	1.84	0.92	Yes	Yes	No	No
	24x28	1.660	1.201	0.986	1.84	0.92	Yes	Yes	No	No
	24x32	1.548	0.992	0.915	1.84	0.92	Yes	Yes	No	Yes
	24x36	1.450	0.836	0.851	1.84	0.92	Yes	Yes	Yes	Yes

Figure 59:

Second iteration with increased shear wall sizes (system selected to represent the CA – Fixed Base outlined in red)

This can be attributed to the fact that most of the shear wall areas fall in the Y-Direction plane. The X-Direction contains smaller length shear walls with less stiffness and therefore increasing the thickness of the walls alone did very little for the direction in question. All of the iterations performed on the structure can be found in Appendix E. The final iteration in question will be the final trial size of shear wall thickness (24 in.) and can be seen in Figure 60.

Model With Moment Frames							Deflection Criteria Met?			
24" Shear Walls	Frame Size	Period	Maximum Drift X (in.)	Maximum Drift Y (in.)	S-3 Δ _a (1.0%)	S-1 Δ _a (0.5%)	S-3 _x	S-3 _y	S-1 _x	S-1 _y
	24x24	1.564	1.210	0.767	1.84	0.92	Yes	Yes	No	Yes
	24x28	1.475	1.028	0.727	1.84	0.92	Yes	Yes	No	Yes
	24x32	1.393	0.882	0.688	1.84	0.92	Yes	Yes	Yes	Yes
	24x36	1.319	0.766	0.652	1.84	0.92	Yes	Yes	Yes	Yes

Figure 60:

Final iteration selection incorporating 24 in. shear walls

Even when using 24 in. shear walls, the moment frames must be at least 24 in. x 32 in. in order to pass the requirements for S-1. As mentioned above, the results of substantially increasing the thickness of the shear walls can be seen in the figure presented above. The structure with the shallowest moment frames subjected in the trial process passed the “Immediate Occupancy” category design limits for the Y-Direction. By observing the three trials above, one can see that increasing the shear walls thickness produces very little effects and appears to converge with increasing thickness. However, the X-Direction relies heavily on the action from the moment frames situated along this direction. The final system used to represent the CA – Fixed Base model is the first structure that passed with 16 in. shear walls. Also, the columns situated towards the base of the structure had to be increased to account for the increase in reinforcement necessary to counteract the earthquake forces seen by the individual members. The columns start at 36 in. x 36 in. at the base of the structure and 28 in. x 28 in. near the top of the structure. The columns sizes of the existing structure were adequate for the slight decrease in overall building weight of the redesign, but because of the relocation, the increased seismic forces produce moments magnified significantly. Because of the higher moments, the columns require an increase in overall reinforcement provided by the existing structure and therefore in increase in dimensions to meet ACE 318-08 requirements for spacing longitudinal bars within a column section.

Base Isolated Structure:

Although codes have mandated steadily increasing force levels, in a severe earthquake a building (if assumed to remain elastic) will encounter forces several times above the designed capacity. However, due to inherent ductility and redundancy within the structure, the building remains standing with some damage. The level of damage is significant in determining the usage after any severe earthquake. If the inclusion of isolators from a technical and first-cost perspective is done, then significant life-cycle cost advantages can be achieved. The costs of the isolation system will be developed later in this report, but typically increases a similarly fixed base structure by about 5%. However, one should keep in mind that this is a very miniscule price to pay for the life safety of others and the need for the hospital patient tower to remain operational during hours directly after the earthquake. The following paragraphs will go into detail regarding the basic principles behind seismic isolation, the preliminary sizing of the isolators and finally, the modeling of the isolation system in ETABS.

Base Isolation:

There are three basic elements in any practical seismic isolation system: a flexible mounting system so that the period of vibration of the total system is lengthened to reduce the force response (Figure 61), a damper or energy dissipater so that the relative deflections between building and ground can be controlled to a practical design level, and a means of controlling low load levels such as wind and smaller magnitude earthquakes.

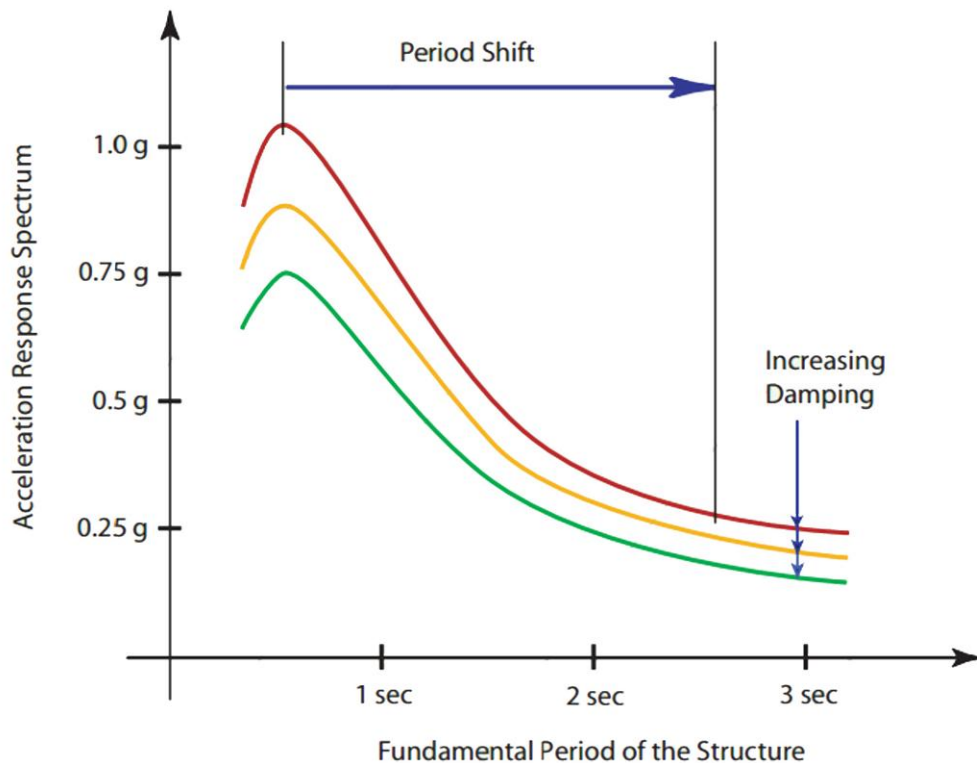

Figure 61:

Increased flexibility/period effects on the overall displacement of the structure (provided by Teratec)

As can be seen in the Figure 61, the increased period shift lowers the acceleration of the floor and ultimately the relative displacement between the levels (interstory drift). This basically causes the entire structure to move as one and slide as the earthquake forces are transferred to the base isolators. The next basic element includes a damping element to decrease the total displacement of the structure. The following figure demonstrates the effects of damping on the existing structure. As the damping increases, the displacement also decreases to limit the overall displacement of the isolation system.

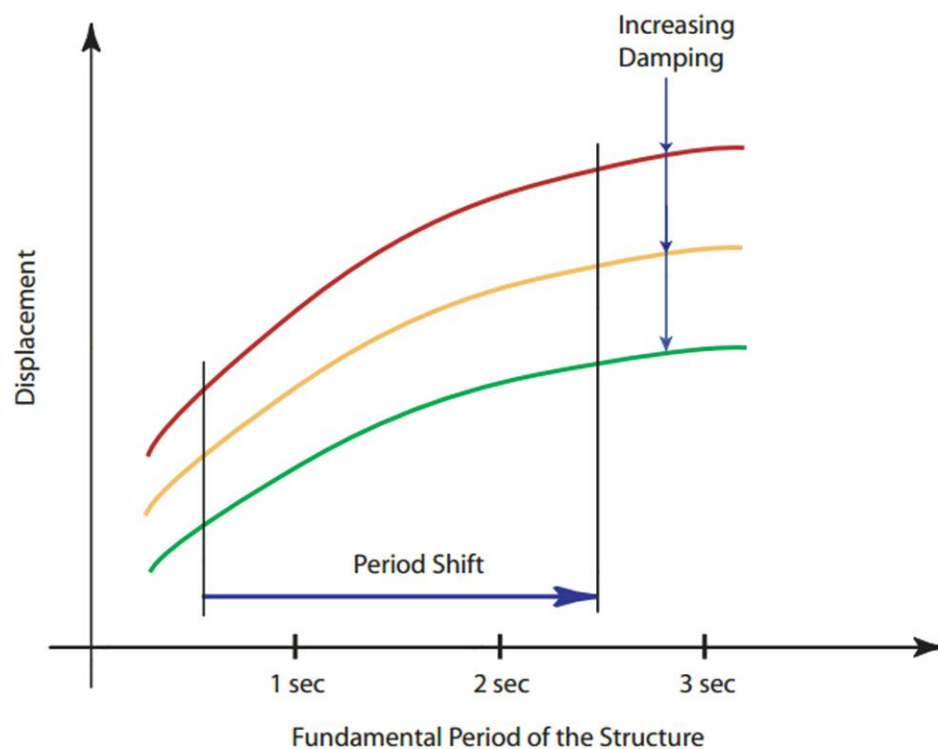

Figure 62:

Increased damping effects on the overall displacement of the structure (provided by Teratec)

Seismic:

Seismic loads were not calculated for this design. Base isolators are designed with effective stiffness values in the plane directions rather than a specific force. A discussion of this process is found in the following subsections.

Base Isolator Layout:

Because the isolators are generally attached near the foundation level, the isolators are situated at each column line that exists on the ground floor. Due to the need for a crawl space to repair any damages and maintenance checks for the individual isolators, just below the ground level serves as a logical place to install the isolators. Having the installation take place directly beneath the ground floor slab not only allows for the necessary crawl space, but the ground floor slab will be advantageous in distributing the forces to the members directly beneath the isolators. If the isolators were placed further down towards

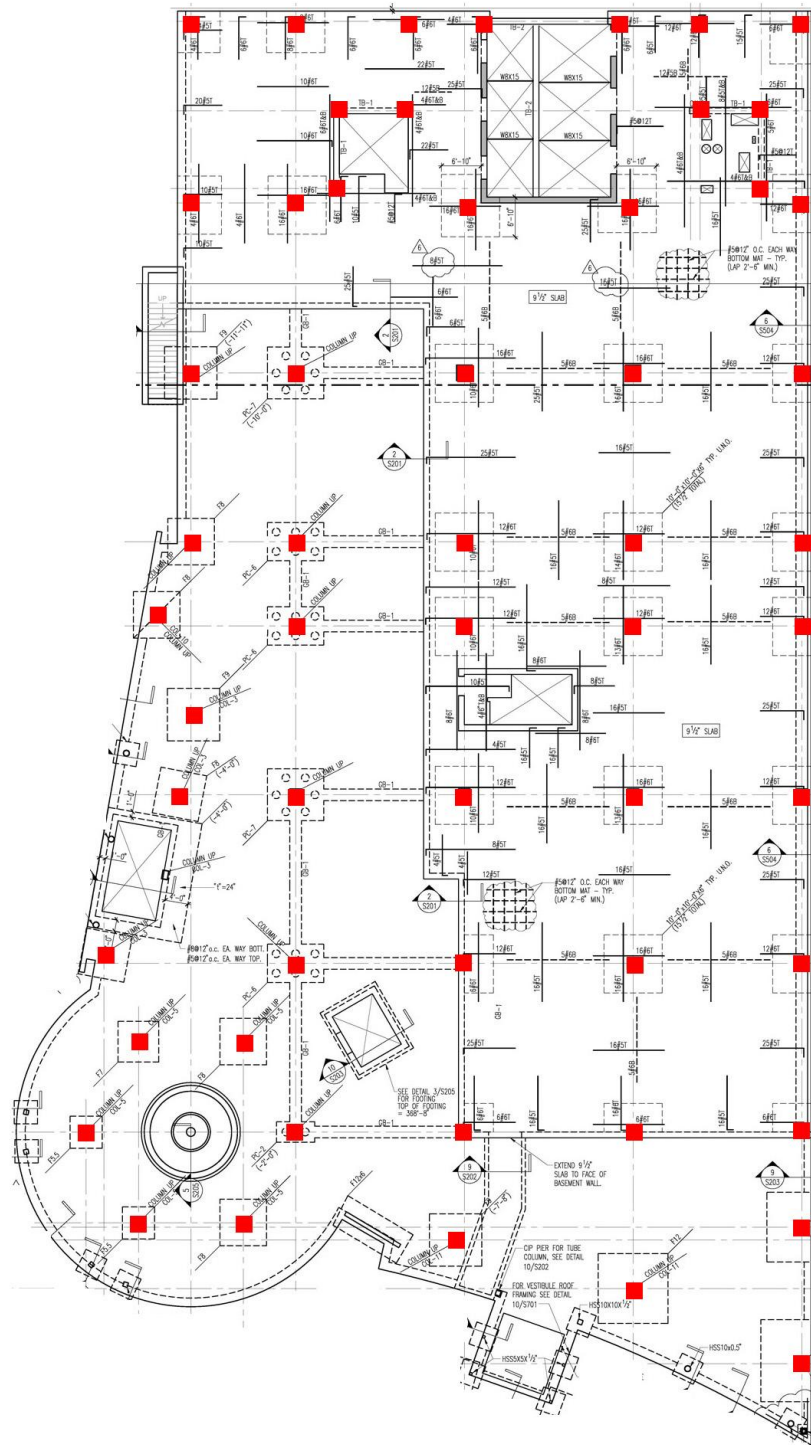

Figure 63:
Ground floor plan with isolator locations highlighted in red (Isolators located directly beneath ground floor level)
(modified drawing provided by Turner Construction)

the basement level, the distribution of the forces into the columns will create large torsional values and shear values within the columns. Therefore, the placement of the isolators directly beneath the ground floor slab is beneficial to the crew inspecting and repairing the isolators without many complications and the distribution of the forces. Another advantageous aspect over the use of other damping devices is architectural concerns. Since the isolator can be installed below grade, the architectural impacts are negligible, while other damping devices (such as viscous fluid dampers) have a stronger probability of affecting the architecture within the structure.

Preliminary Sizes:

Base isolators are designed using an effective damping value. In order to properly calculate the design conditions of the isolator, a hysteresis curve of the isolator during various testing cycles is needed. The author was unable to obtain a detailed report of the specific values of isolators but the calculations were performed in a specific way to find the effective stiffness needed for the structure at both the design displacement and the maximum displacement. A sample hysteresis curve is shown below for visual purposes.

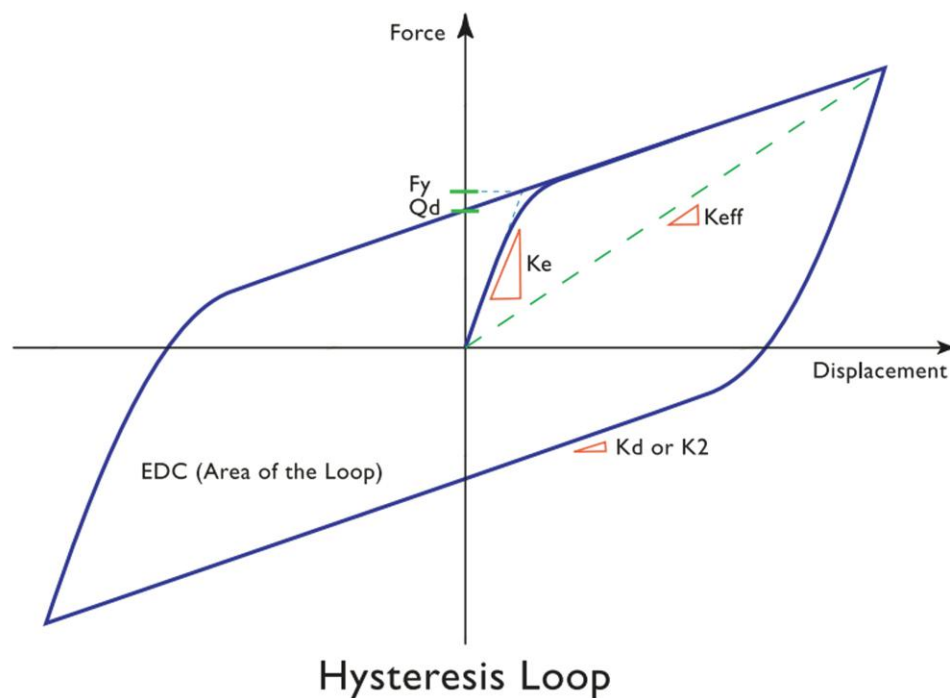

Figure 64:

Hysteresis loop of a typical isolator with coefficients shown for clarity (provided by Teratec)

Sample calculations that go through the preliminary design are shown in Appendix F. In order to start off the calculations, the effective period at design displacement and maximum displacement were assumed. These values are typically 5-6 times the fixed base structure's period. The period of all the structures mentioned in this report are shown in Figure 65 for comparison purposes. The period was significantly decreased (1.0 second difference) by adding the moment frames and extra shear wall.

	One-Way Slab w/ Moment Frames - Fixed Base (Sacramento, CA)	Two-Way Flat Slab (Falls Church, VA)
Entire Structure	$T_x = 1.94$ $T_y = 1.68$ $T_z = 1.03$	$T_x = 2.94$ $T_y = 2.11$ $T_z = 1.73$
Isolated Portion with Fixed Base Conditions	$T_x = 1.78$ $T_y = 1.52$ $T_z = 0.96$	

Figure 65:

Period of the various structures analyzed within this report

While doing research on the topic of base isolators, it was found that isolators typically have a damping percentage in the range of 10-20%. Going through the complete calculations eventually results in the design displacement and maximum displacement as well as total displacement. Finally, the lateral forces expected to be seen by the structural elements below the isolation system and the structural elements above the isolation plane are calculated. Appendix F contains one preliminary trial for the sizing of the isolator.

Earthquake Ground Motion History Record Selection and Scaling:

In order to perform the time history analysis to confirm the preliminary design, earthquake ground motion history records had to be selected and scaled. The code states that the bare minimum of three records must be used; however, if less than seven records are used, the maximum envelope of the histories must be taken into consideration. Due to the irregularities of the structure, motions were applied to multiple directions simultaneously with the perpendicular direction receiving 30% of the loading in the opposite direction of interest. Therefore, a total of 6 acceleration records from FEMA P695 were chosen. To be on the conservative side, near-field records were chosen to account for the proximity of fault lines. The ground acceleration histories for these records were retrieved from the PEER NGA website, which contains a database for various ground motions. The graphs for the various earthquakes used can be found in Appendix G. The spectra for each ground motion history was also recovered from this website and compared to the code required design response spectrum. The records were all scaled according based on the response spectrum and gravity (386.4 in/sec^2). It is desired to scale the records so that the residuals between the record's scaled spectrum and target spectrum is minimized between $0.2T_L$ and $1.5T_L$. The following figures represent the normalized acceleration (including the scale factors) for the X-Direction time history records.

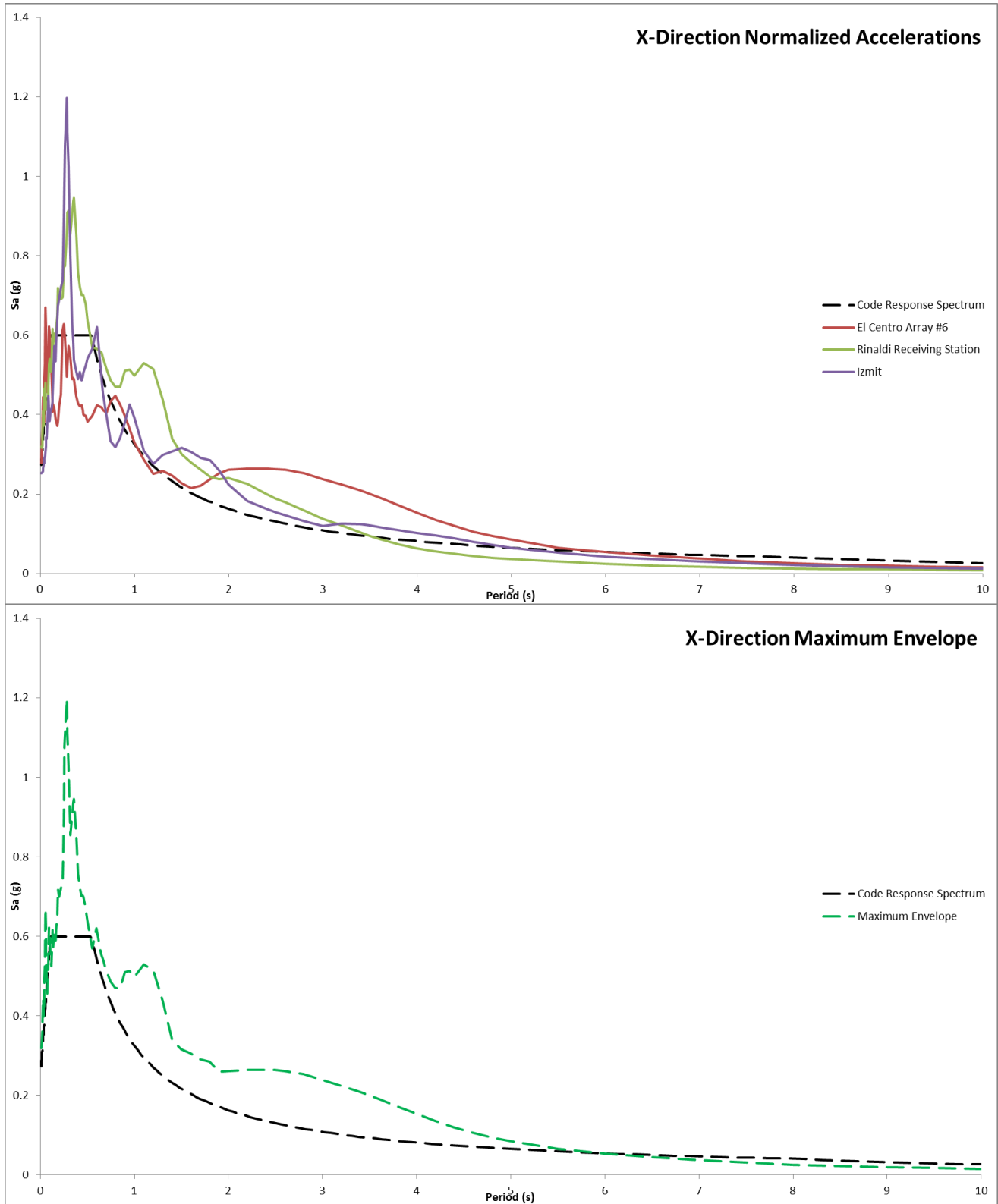

Figure 66:
Normalized accelerations in the X-Direction

Nonlinear Properties Assigned to Isolator Links:

Nonlinear properties were assigned to the isolator links within ETABS. The first step involved sizing the isolator for the maximum axial load the isolator would experience. Two columns were selected to be calculated with the maximum axial load governing the design selection. An interior column experiences a maximum axial load of roughly 2130 kips while an exterior column receives roughly 1690 kips. Therefore, the isolator was selected using the maximum axial load. The following cut sheet (Figure 67) from Teratec, a seismic isolation manufacturer, displays the sizes of isolators they manufacture with the design properties.

Isolator Diameter, D_I (in)	DESIGN PROPERTIES			Maximum Displacement, D_{max} (in)	Axial Load Capacity, P_{max} (kips)
	Yielded Stiffness, K_d (k/in)	Characteristic Strength, Q_d (kips)	Compression Stiffness, K_v (k/in)		
12.0	1-5	0-15	>250	6	100
14.0	1-7	0-15	>500	6	150
16.0	2-9	0-25	>500	8	200
18.0	2-11	0-25	>500	10	250
20.5	2-13	0-40	>1,000	12	300
22.5	3-16	0-40	>3,000	14	400
25.5	3-20	0-50	>4,000	16	600
27.5	3-24	0-50	>4,500	18	700
29.5	4-27	0-60	>5,000	18	800
31.5	4-30	0-60	>6,000	20	900
33.5	4-35	0-80	>7,000	22	1,100
35.5	4-35	0-80	>8,000	22	1,300
37.5	4-35	0-110	>10,000	24	1,500
39.5	5-36	0-110	>11,000	26	1,700
41.5	5-36	0-130	>12,000	28	1,900
45.5	6-37	0-150	>16,000	30	3,100
49.5	7-38	0-170	>21,000	32	4,600
53.5	8-40	0-200	>29,000	34	6,200
57.1	9-41	0-230	>30,000	36	7,500
61.0	10-42	0-230	>37,000	36	9,000

Figure 67:

Isolator properties based on axial load, taken from Teratec

Because the manufacturing gives ranges for the various design properties, numerous iterations were performed to optimize the structure in order to meet the S-1 performance. Two sample iterations are shown below to represent the extreme values. The final design that meets the S-1 "Immediate Occupancy" design category is the latter iteration with the design properties of the link isolator shown below that table. These values were used in ETABS to model the isolation system and the drift values easily passed. In order to properly model the nonlinear properties given to the base isolators in ETABS, Ritz vectors were used instead of the typical Eigenvector analysis. Although Eigenvector analysis is acceptable for traditional modeling, the Ritz vector analysis accounts for the nonlinear properties of the isolation system far better than the typical analysis procedure.

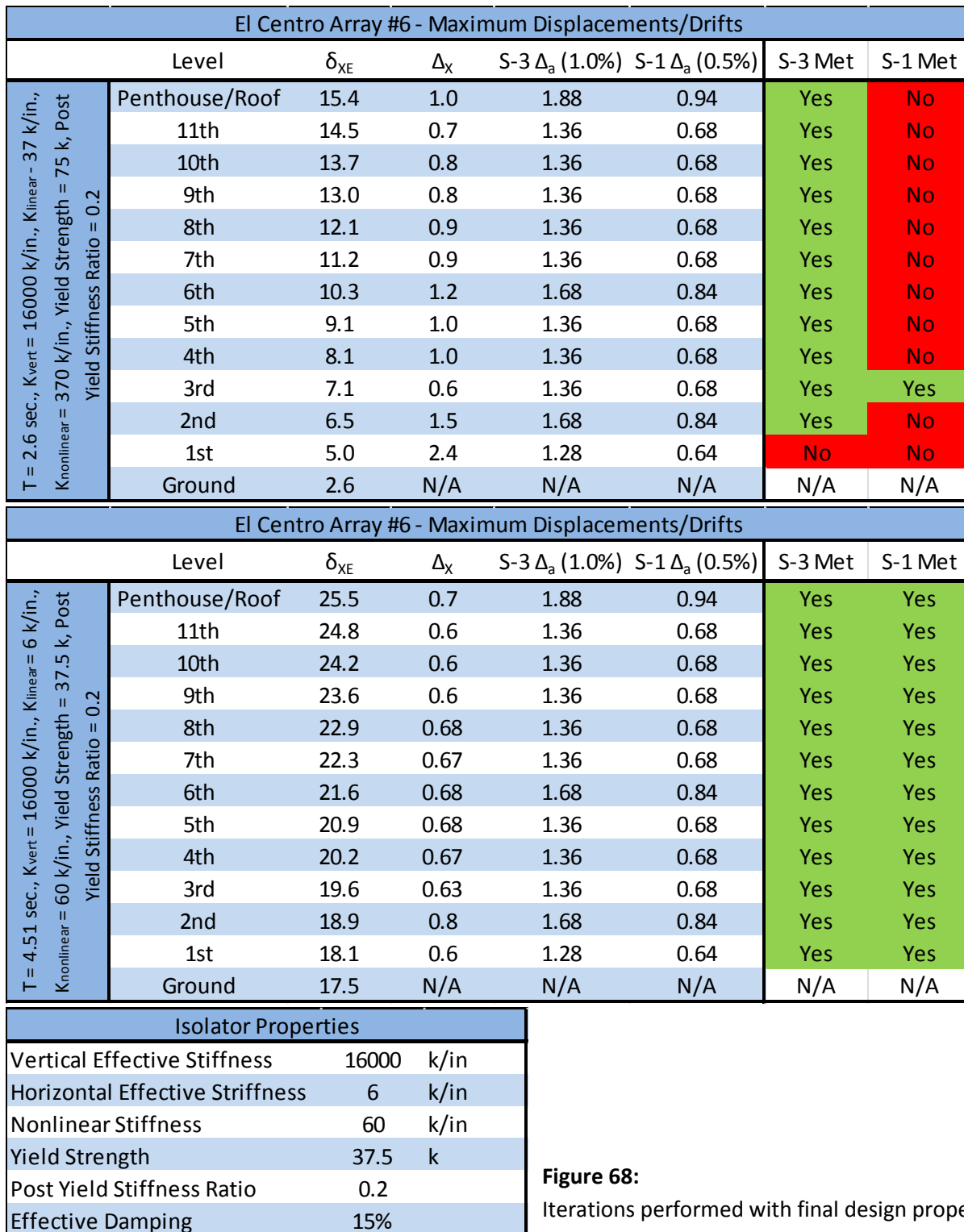

Figure 68:
Iterations performed with final design properties listed

System Finalization:

Once the drifts were found to be adequate for the structure, hand calculation were performed to size the columns running the entire height of the structure. Axial loads were calculated for each floor level and the maximum moment from each earthquake was used to design the columns in spColumn (with the Redundancy factor, ρ , considered). The final design for a typical column running the entire height of the structure can be found in the figure below. A sample output from spColumn can be found in Appendix F.

Column Sizes for Base Isolation System (G-3)							
Col. Supporting	P_U (k)	M_U (ft-k)	Economical Column Dimension	Rebar	Column Selection	Rebar Selection	
Ground	2128	2411	34"x34"	24 #11	34"x34"	24 #11	
1 st	1969	1341	28"x28"	20 #11	30"x30"	16 #11	
2 nd	1806	187	24"x24"	4 #11	26"x26"	16#11	
3 rd	1647	151	24"x24"	4 #11	26"x26"	16#11	
4 th	1490	1030	26"x26"	16 #11	26"x26"	16#11	
5 th	1333	982	24"x24"	20 #11	26"x26"	16 #11	
6 th	1075	779	24"x24"	16 #11	26"x26"	16 #11	
7 th	918	884	24"x24"	20 #11	26"x26"	16 #11	
8 th	761	808	24"x24"	16 #11	24"x24"	16 #11	
9 th	605	767	24"x24"	12 #11	24"x24"	12 #11	
10 th	448	723	24"x24"	8 #11	24"x24"	12 #11	
11 th	289	687	24"x24"	8 #11	24"x24"	12 #11	
Penthouse/Roof	122	718	24"x24"	12 #11	24"x24"	12 #11	

Figure 69:

Column Sizes for isolated structure

System Summary/Comparison:

Summary of Systems			
System	Moment Frame Sizes	Shear Wall Thickness	Maximum Drift Values (in.)
Fixed Base Structure	24" x 36"	16"	0.836
Isolated Structure	24" x 24"	12"	0.8

Figure 70:

Summary of structural element sizes for the two systems

The figure above illustrates the effectiveness of the base isolation system to decrease the sizes of the structural members when similar performance requirements are met. In this case, both of the above structures meet the S-1 "Immediate Occupancy" performance requirements.

Construction Management Breadth

The purpose of this breadth was to investigate how the changes to the superstructure will alter the building construction schedule and cost. Certain features were considered in this breadth, such as:

- The increase in lead time required for the manufacturing and design of the base isolation system
- Installation and float time required for the base isolation system
- Additional materials required for the fixed base system

To quantify this impact, a detailed cost estimate was constructed for the structural elements in both of the designed systems. In addition, a simplified construction schedule was developed to compare the estimated time of completion for the fixed base system versus the base isolated structure. As a result of this study, a more in depth comparison can be conducted toward the feasibility of implementing a base isolation system.

Cost Estimate:

A rough estimate for both of the design systems was compiled using RS Means. It was assumed that the cost of the isolators included the additional costs associated with the foundation alterations. The costs for the isolators themselves was difficult to obtain; however, through an industry professional, the costs associated with the isolation system can be found in Figure 71.

Isolator Costs	
Isolator D(in.)	Price (\$)
12.0	\$ 8,000.00
14.0	\$ 8,490.00
16.0	\$ 8,980.00
18.0	\$ 9,469.00
20.5	\$10,082.00
22.5	\$10,571.00
27.5	\$11,796.00
29.5	\$12,886.00
31.5	\$12,776.00
33.5	\$13,265.00
35.5	\$13,755.00
37.5	\$14,245.00
39.5	\$14,735.00
41.5	\$15,225.00
45.5	\$16,204.00
49.5	\$17,184.00
53.5	\$18,163.00
57.1	\$19,045.00
61.0	\$20,000.00

Figure 71:
Costs associated with an individual isolator

The contact was able to provide the general range of \$8,000 - \$20,000 and these values were given to the smallest and largest of the isolator dimensions. For sizes between the extreme ends, interpolation was utilized to obtain a rough estimate of the cost for the isolator chosen for this particular project. In this instance, the 45.5" diameter isolator will add roughly \$16,000 per isolator. A detailed cost for each floor can be found in Appendix H.

The detailed cost breakdown includes the costs associated with the concrete for all cast-in-place members, formwork, reinforcement and finishing of the concrete systems. These quantities were taken into account for each floor to develop the project cost for both the fixed base system and the isolated structure. The costs associated with the base isolation system include the costs for the individual isolators, crane to move the isolators, and a three crew labor to install the system. This crew includes the two field workers to attach the isolation system to the piers and the crane worker. Figure 72 below shows the cost differences between the designed systems with the actual cost of the existing structure shown for comparison purposes. With the relocation to Sacramento, California, the additional costs associated with conforming to S-1 performance requirements totals \$1,094,445. The expenses needed to install and utilize the base isolation system for the same performance requirements will cost an additional \$1,778,738 when compared to the existing structure. Overall, the base isolation system will cost \$684,293 dollars beyond the fixed base system for similar performance requirements

Summary of Costs			
	Without Location Factor	With Location Factor	Difference With Base Model
Original Structure	\$5,250,302	N/A	-
Fixed Base System	\$5,773,200	\$6,344,747	\$1,094,445
Isolated Structure	\$6,395,851	\$7,029,040	\$1,778,738

Figure 72:

Summary of the superstructure costs

Figure 73 below shows the costs strictly associated with the isolation system. One the following page, Figure 74 depicts the costs associated with the same typical floor plan for both the fixed base system and the isolation system.

Isolator Costs						
Base Isolator Costs						
Isolator (45.5")	Costs: \$	16204.00	per isolator	x	60.0	isolators = \$ 972,240.00
Installation Costs						
1 Crane - 2000lb	Costs: \$	2475.00	day	x	30	days = \$ 74,250.00
Mild Steel Reinforcing Costs						
2 Laborers	Costs: \$	529.60	day	x	30	days = \$ 15,888.00
1 Crane Operator	Costs: \$	266.40	day	x	30	tons = \$ 7,992.00
						Total = \$ 1,070,370.00

Figure 73:

Total cost pertaining only to the isolation system

4 th Floor (Fixed Base System)									
Concrete Costs									
Slab (5")	Materials:	\$ 109.00	per cu. yrds	x	275.2	cu. yrds	=	\$	29,993.92
	Labor:	\$ 41.40	per cu. yrds	x	275.2	cu. yrds	=	\$	11,392.19
Beams/ Girder (24"x36")	Materials:	\$ 109.00	per cu. yrds	x	265.6	cu. yrds	=	\$	28,947.13
	Labor:	\$ 35.55	per cu. yrds	x	265.6	cu. yrds	=	\$	9,441.01
Joists (12"x24")	Materials:	\$ 109.00	per cu. yrds	x	95.9	cu. yrds	=	\$	10,448.86
	Labor:	\$ 87.00	per cu. yrds	x	95.9	cu. yrds	=	\$	8,339.92
Columns (28"x28")	Materials:	\$ 202.00	per cu. yrds	x	67.1	cu. yrds	=	\$	13,550.83
	Labor:	\$ 22.75	per cu. yrds	x	67.1	cu. yrds	=	\$	1,526.15
Walls (16")	Materials:	\$ 109.00	per cu. yrds	x	68.8	cu. yrds	=	\$	7,504.04
	Labor:	\$ 26.40	per cu. yrds	x	68.8	cu. yrds	=	\$	1,817.49
Formwork Costs									
Slab (5")	Materials:	\$ 2.92	per sq. ft.	x	15850	sq. ft.	=	\$	46,282.00
	Labor:	\$ 4.12	per sq. ft.	x	15850	sq. ft.	=	\$	65,302.00
Beams/ Girder (24"x36")	Materials:	\$ 0.66	per sq. ft.	x	5844	sq. ft.	=	\$	3,856.71
	Labor:	\$ 5.20	per sq. ft.	x	5844	sq. ft.	=	\$	30,386.20
Joists (12"x24")	Materials:	\$ 0.99	per sq. ft.	x	5177	sq. ft.	=	\$	5,124.74
	Labor:	\$ 5.45	per sq. ft.	x	5177	sq. ft.	=	\$	28,211.93
Columns (28"x28")	Materials:	\$ 0.86	per sq. ft.	x	3913	sq. ft.	=	\$	3,365.27
	Labor:	\$ 3.04	per sq. ft.	x	3913	sq. ft.	=	\$	11,895.83
Walls (16")	Materials:	\$ 0.74	per sq. ft.	x	1883	sq. ft.	=	\$	1,393.63
	Labor:	\$ 4.58	per sq. ft.	x	1883	sq. ft.	=	\$	8,625.44
Mild Steel Reinforcing Costs									
	Materials:	\$ 980.00	per tons	x	42.6	tons	=	\$	41,743.20
	Labor:	\$ 980.00	per tons	x	42.6	tons	=	\$	41,743.20
								Total =	\$ 410,891.70
4 th Floor (Isolated Structure)									
Concrete Costs									
Slab (5")	Materials:	\$ 109.00	per cu. yrds	x	275.2	cu. yrds	=	\$	29,993.92
	Labor:	\$ 41.40	per cu. yrds	x	275.2	cu. yrds	=	\$	11,392.19
Beams/ Girder (24"x24")	Materials:	\$ 109.00	per cu. yrds	x	162.9	cu. yrds	=	\$	17,758.98
	Labor:	\$ 35.55	per cu. yrds	x	162.9	cu. yrds	=	\$	5,792.03
Joists (12"x24")	Materials:	\$ 109.00	per cu. yrds	x	95.9	cu. yrds	=	\$	10,448.86
	Labor:	\$ 87.00	per cu. yrds	x	95.9	cu. yrds	=	\$	8,339.92
Columns (26"x26")	Materials:	\$ 202.00	per cu. yrds	x	53.7	cu. yrds	=	\$	10,840.67
	Labor:	\$ 22.75	per cu. yrds	x	53.7	cu. yrds	=	\$	1,220.92
Walls (12")	Materials:	\$ 109.00	per cu. yrds	x	68.8	cu. yrds	=	\$	7,504.04
	Labor:	\$ 29.00	per cu. yrds	x	68.8	cu. yrds	=	\$	1,996.49
Formwork Costs									
Slab (5")	Materials:	\$ 2.92	per sq. ft.	x	15850	sq. ft.	=	\$	46,282.00
	Labor:	\$ 4.12	per sq. ft.	x	15850	sq. ft.	=	\$	65,302.00
Beams/ Girder (24"x24")	Materials:	\$ 0.66	per sq. ft.	x	4945	sq. ft.	=	\$	3,263.37
	Labor:	\$ 5.20	per sq. ft.	x	4945	sq. ft.	=	\$	25,711.40
Joists (12"x24")	Materials:	\$ 0.99	per sq. ft.	x	5177	sq. ft.	=	\$	5,124.74
	Labor:	\$ 5.45	per sq. ft.	x	5177	sq. ft.	=	\$	28,211.93
Columns (26"x26")	Materials:	\$ 0.86	per sq. ft.	x	3355	sq. ft.	=	\$	2,884.93
	Labor:	\$ 3.04	per sq. ft.	x	3355	sq. ft.	=	\$	10,197.89
Walls (12")	Materials:	\$ 0.74	per sq. ft.	x	1883	sq. ft.	=	\$	1,393.63
	Labor:	\$ 4.58	per sq. ft.	x	1883	sq. ft.	=	\$	8,625.44
Mild Steel Reinforcing Costs									
	Materials:	\$ 980.00	per tons	x	38.7	tons	=	\$	37,948.36
	Labor:	\$ 980.00	per tons	x	38.7	tons	=	\$	37,948.36
								Total =	\$ 378,182.06

Figure 74:
Comparison of a typical floor (4th floor) for both the fixed base system (top) and the isolation system (bottom)

Project Schedule:

Using RS Means, the daily output values used to calculate the estimated time to complete each task were found. The total duration to complete the structure for the various floor systems is summarized in Figure 75. The duration for the original structure was provided by Turner Construction. The schedules for all three systems can be found in Appendix H. A sample floor plan calculation for the duration can be seen in Figure 76 below.

Summary of Durations	
Duration (Months)	
Original Structure	15
Fixed Base System	18
Isolated Structure	19

Conclusion:

Figure 75:

Summary of the durations calculated for the redesigned systems

Schedule Calculations for S-1 Fixed Base Structure					
Ground Floor		Daily Output (units/day)		Quantity	Days Required
Formwork	Slab	500	sq. ft	25513	51.0
	Beam/Girders	395	sq. ft	8483	21.5
	Joists	377	sq. ft	9135	24.2
	Columns	460	sq. ft	6390	13.9
	Walls	450	sq. ft	1966	4.4
	Mild Steel Reinforcing	2.3	tons	74	32.3
Placement	Slab	95	cubic yds	394	4.1
	Beam/Girders	90	cubic yds	250	2.8
	Joists	60	cubic yds	169	2.8
	Columns	140	cubic yds	90	0.6
	Walls	120	cubic yds	50	0.4
Schedule Calculations for S-1 Base Isolated Structure					
Ground Floor		Daily Output (units/day)		Quantity	Days Required
Formwork	Slab	500	sq. ft	25513	51.0
	Beam/Girders	395	sq. ft	7178	18.2
	Joists	377	sq. ft	9135	24.2
	Columns	460	sq. ft	4260	9.3
	Walls	450	sq. ft	1966	4.4
	Mild Steel Reinforcing	2.3	tons	68	29.4
Placement	Slab	95	cubic yds	394	4.1
	Beam/Girders	90	cubic yds	153	1.7
	Joists	60	cubic yds	169	2.8
	Columns	140	cubic yds	72	0.5
	Walls	110	cubic yds	37	0.3
Base Isolation*		Daily Output (units/day)		Quantity	Days Required
	Slab	2	day	60	30.0
*Requires a lead time of roughly 6 weeks for the beginning of delivery and a total of 12-15 weeks of total project delivery time					

Figure 76:

Comparison of durations for the ground floor. The duration for base isolator installation is also included.

Conclusions:

As a result of this study, it was determined that the existing structure was the least expensive to construct. This was assumed coming into the study since the other two structures are designed for much higher performance standards in regards to strength and serviceability criteria. Therefore, a comparison between the designed structures and the existing structure is non-substantial. The major comparison in terms of costs occurs between the two designed structures to meet the S-1 performance requirements. The structure alone for the base isolation system is cheaper than the fixed base system due to the increased member sizes for the latter design. However, the isolation system costs just over \$1 million (roughly 5% of the structural costs) when compared with the fixed base system when labor and material costs are included. The feasibility of the isolation system will be discussed in further details in the overall Conclusion section of the entire report.

In terms of the schedule, it was determined that the existing structure took the least amount of time to construct the superstructure portion of the building. The two designed structures have longer duration times for two main reasons. Both of these systems require an increase in the amount of formwork needed to pour the concrete and reinforcement placement for the increased moments and shears. Also, as mentioned in the previous paragraph, the systems have members much larger than the existing structure in order to meet the desired "Immediate Occupancy" category. One important note is that the isolation system did not lead to a huge increase in duration time when compared with the fixed base system. To determine the length of installation for the isolators, it was assumed two could be completed per day. This may seem like a conservative value, but float time is necessary in this instance for the possibility of delays with the concrete crews, weather or any other possible interruptions. Also, the professional within the industry stated that the lead time required for the delivery of the isolators is approximately 15 weeks. Evidently, this turned out to be close to the duration of the foundation system. Therefore, the isolators could be designed and ordered before the start of the foundation work meaning the lead time for the isolators in this case is not of a huge concern. However, the slight increase in duration for the completion of the base isolation system will lead to additional costs, interim financing and a delay in productivity. All of these will increase the costs associated with this system since time is money.

Mechanical/Building Enclosure Breadth

The building enclosure surrounding much of the structure consists of curtain walls and a precast concrete paneling system. The façade changes from this precast concrete system to a curtain wall assembly to add architectural details to the façade system. With this in mind, an alternate glazing system will be analyzed to determine the effects on the wall assembly and ultimately the heating/cooling loads. From here, a cost analysis was conducted to evaluate the potential savings of the proposed building enclosure. This breadth will only examine the existing façade assembly and alternate façade system placed in Sacramento, California. The following figures depict the curtain wall system integrated with the precast concrete panel system.

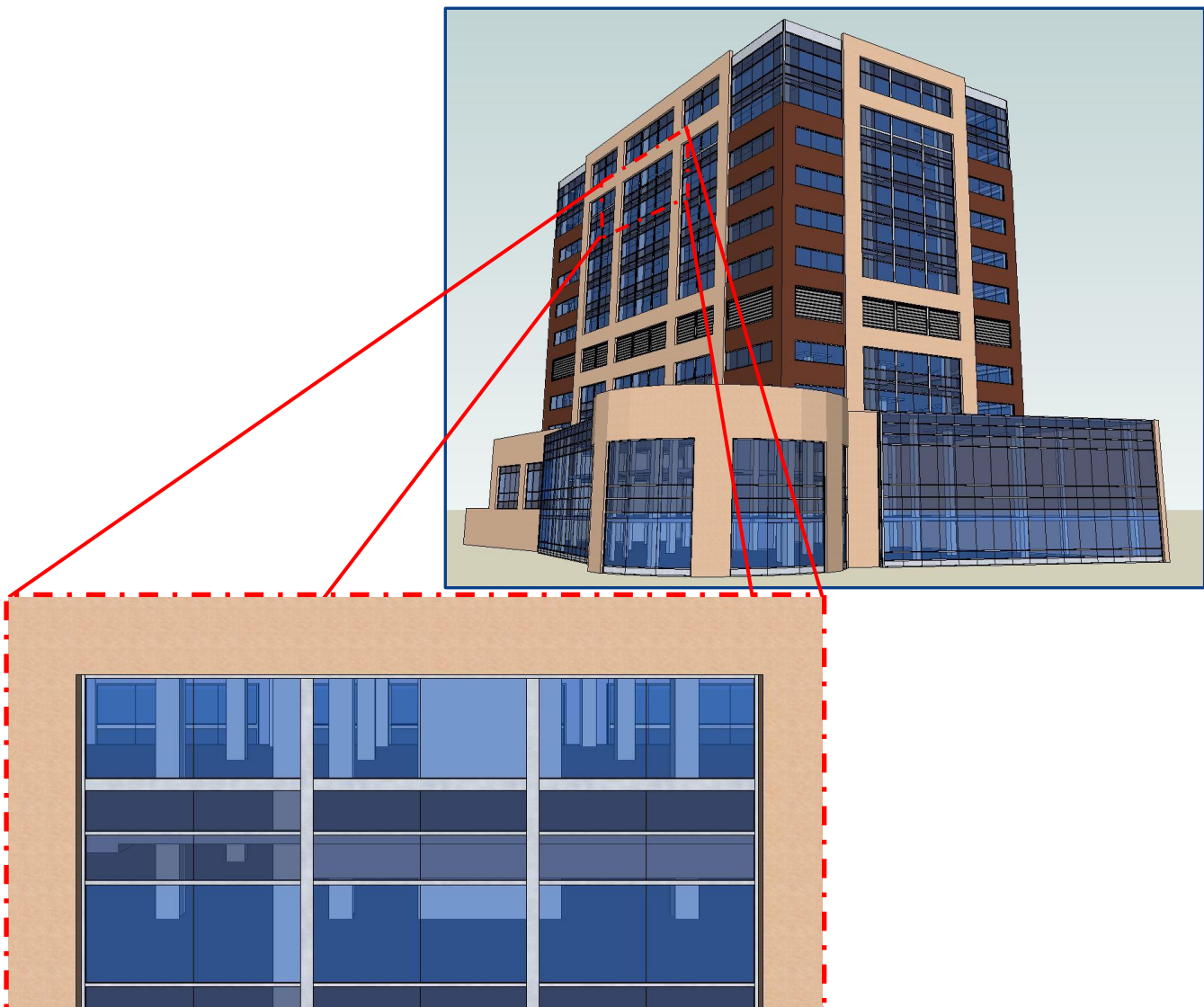

Figure 77:

Façade of the South Patient Tower created using SketchUp

Existing Conditions/Purposed Conditions:

The thermal properties of the existing building envelope systems are summarized in Figure 78 below.

South Patient Tower - Falls Church, VA		
Assembly	Construction	U-Value (BTU/hr-ft ² -°F)
Slab*	8" Concrete	0.49
Roof*	6" Concrete + 6" Insulation	0.024
Wall*	Steel Framed Wall + 3" Ins.	0.043
Window*	Low-e Double Pane**	0.29
* Obtained from construction drawings		
** Shading Coefficient = 0.36		

Figure 78:

Thermal values obtained from the mechanical drawings for the South Patient Tower

In order to check the design values used by the mechanical engineers, the façade assembly was modeled in H.A.M. Toolbox and the resulting R-values were calculated.

Layer	Generic Material	Thick.	R Val.
1	brick, facing, 1/2 in.	0.50	0.12
2	concrete wall, 6 in.	6.02	0.87
3	cavity, 2 in.	2.00	0.98
4	poly film. (4mil)	0.00	0.12
5	rigid ins. (extru.), 4 in.	4.00	20.55
6	poly film. (4mil)	0.00	0.12
7	steel stud, 3-1/2 in.	3.54	0.12
8	gypsum bd., 5/8 in. (#2)	0.63	0.46
9			
10			
11			
12			
	Total or (Layer 0)	16.70	23.32

Figure 79:

R-value analysis from H.A.M. Toolbox

Using the R-values provided by H.A.M. Toolbox, the values were summed up and the inverse was taken in order to calculate the U-value. The U-value is important in the modeling process and a more accurate measure of thermal performance compared to R-values.

R-Value Analysis of Wall Assembly (H.A.M)	
Layer	R-Value
1/2" Thick Brick Face	0.12
5 1/2" Precast Panel	0.87
2" Air Gap	0.98
4" Glass Insulation Board w/ Vapor Barrier	20.67
1/4" Air Gap with Vapor Barrier	0.12
3 5/8" Metal Stud	0.12
5/8" Gypsum Board	0.46
Σ R-Values =	23.34
U-Value = 1/(ΣR-Values) =	0.0428
*0.47% difference compared to design value	

Figure 80:

U-value calculation and comparison to the existing value

As seen in Figure 80, the calculated U-value and the value used by the mechanical engineers were nearly identical. Next, the Condensation Tool offered by H.A.M. Toolbox was utilized to ensure that the existing façade would not have any condensation issues within the wall assembly when placed in Sacramento, California. The figures on the following page display the condensation results for both the summer and winter conditions (Figure 81). The existing façade did not have any issues with condensation with the move to California, and therefore, the existing precast concrete assembly is adequate to be used for the remaining portion of this breadth.

Once the U-value for the wall could be considered accurate, the next step was choosing an alternate glazing type. The proposed glazing is Oldcastle BuildingEnvelope SunGlass Low-E #2 argon fill and the exterior glazing will be tinted blue. The new U-value for the insulating glass unit (IGU) proposed is 0.24 and a shading coefficient of 0.28. The inner lite consists of a ¼ in. uncoated clear glass layer, while the outer lite has a similar thickness but with the Low-E coating. The ½ in. air space is filled with argon to increase the thermal performance of the glazing assembly. The specification for the proposed glazing assembly can be found in Appendix I.

TRACE Model:

A Trace model was created to represent a typical patient room in the South Patient Tower. Templates in the TRACE model consist of internal loads, airflow, thermostat, construction, and room templates. The airflow template calculates the heating and cooling demand based on ventilation, infiltration, room exhaust and minimum variable air volume. Utilizing ASHRAE, the values for the infiltration rates and

required room exhaust were found. The construction values for the glazing were ignored in TRACE and the U-values for the existing and proposed designs were used in place of the defaults.

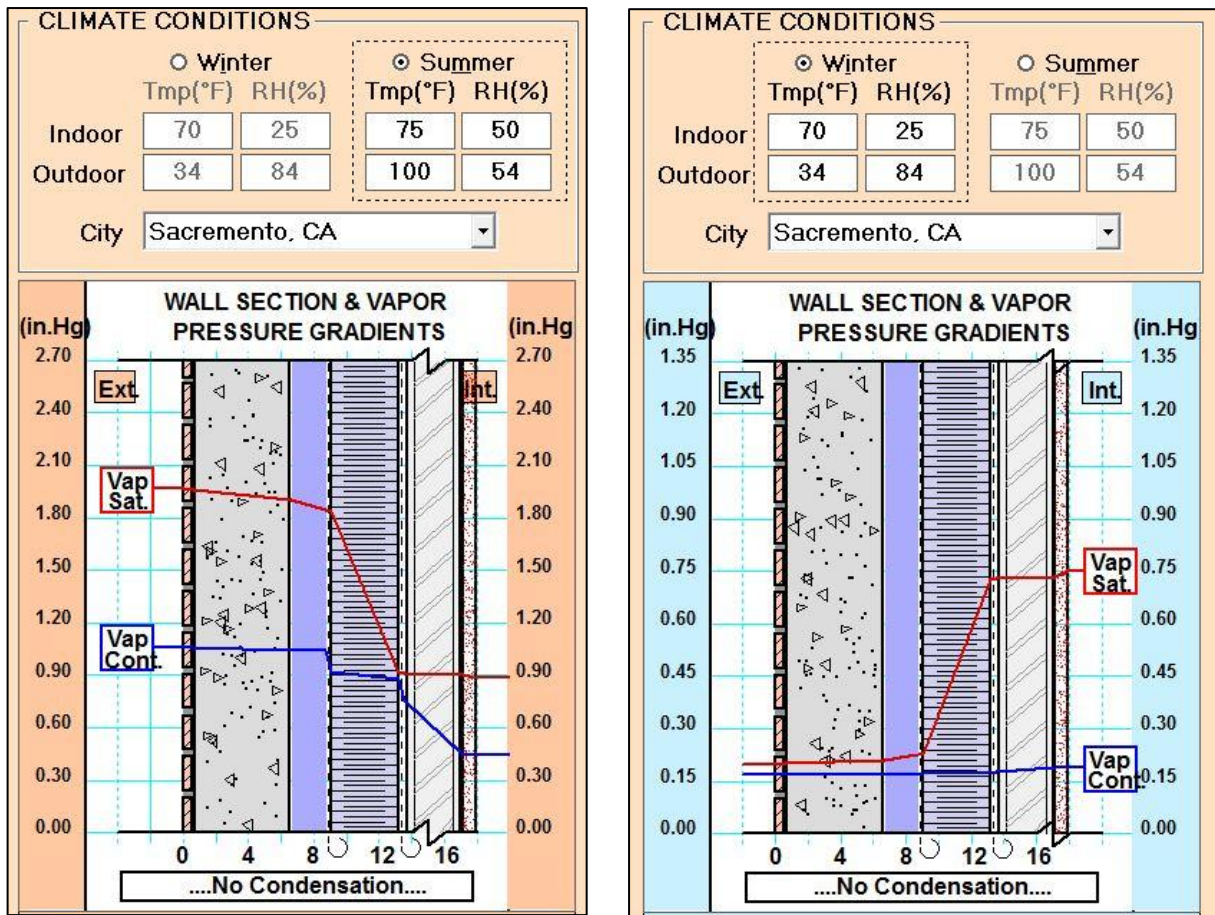

Figure 81:
Condensation results from H.A.M. Toolbox

Results:

Once the two alternatives were created in TRACE, the various loads associated with the change in the glazing were obtained from the output files. The values in following figures are the cooling and heating loads found within the typical patient room from the TRACE output (Appendix I).

Existing Glazing									
Cooling							Total (Btu/h)		
	Glass	Wall	Infiltration	Lights	People	Equipment	Envelope	Internal Loads	Total
Patient Room	1992	127	186	241	1080	1466	2305	2787	5092
Proposed Glazing									
Cooling							Total (Btu/h)		
	Glass	Wall	Infiltration	Lights	People	Equipment	Envelope	Internal Loads	Total
Patient Room	1548	127	186	241	1080	1466	1861	2787	4648

Figure 82:
Cooling loads for the existing and proposed glazing systems for a typical room

Existing Glazing								
Heating						Total (Btu/h)		
Glass	Wall	Infiltration	Lights	People	Equipment	Envelope	Internal Loads	Total
-584	-106	-266	0	0	0	-956	0	-956
Proposed Glazing								
Heating						Total (Btu/h)		
Glass	Wall	Infiltration	Lights	People	Equipment	Envelope	Internal Loads	Total
-483	-106	-266	0	0	0	-855	0	-855

Figure 83:

Heating loads for the existing and proposed glazing systems for a typical room

Cost Comparisons:

Estimates for the glazing were provided in cost per square foot from Oldcastle Glazing. Figure 84 below shows the cost comparison of the existing system compared to the alternate glazing assembly. Framing was neglected in the calculations of the costs with the assumption that the framing would remain constant. The overall cost of the proposed glazing system will increase the upfront expenses by roughly 7%.

Glazing Cost Comparison			
	Existing	Proposed	Difference
Area	19214	19214	
Cost/SQ FT	\$12.00	\$12.80	
Total Cost	\$230,568.00	\$245,939.20	\$ 15,371.20

Figure 84:

Cost comparison of glazing selection

Energy Cost Savings:

Analyzing how the increase in thermal performance affects the patient rooms, further calculations must be made with the cooling and heating loads calculated using TRACE (Figures 82 and 83). Degree days is a fairly accurate method to approximate the heating and cooling demand for the entire space. Figure 85 on the following page displays the cooling and heating degree hours per month. Using an assumed interior temperature of 70°F and the average daily temperature values for Sacramento resulted in 85,044 degree hours for heating and 11,076 degree hours for cooling. According to the U.S. Energy Information Administration (EIA), the average cost per kWh for Sacramento, California is 11.79 cents/kWh. Using a conversion factor to transform the TRACE values to kWh, the total energy savings for a typical patient room could be found by multiplying the cost of electricity by the load for the room in question. Figure 86 on the following page displays the energy savings for a typical patient room located on the 11th floor for heating and cooling loads. The TRACE output for the existing glazing system and the proposed redesign can be found in Appendix I.

Degree Days							
Month	Interior	Exterior	ΔT	Deg. Days	Deg. Hours	Heating	Cooling
Jan	70	46.5	23.5	728.5	17484	17484	
Feb	70	51	19	532	12768	12768	
Mar	70	55.5	14.5	449.5	10788	10788	
Apr	70	59.5	10.5	315	7560	7560	
May	70	66	4	124	2976	2976	
Jun	70	71.5	-1.5	-45	-1080		-1080
Jul	70	76	-6	-186	-4464		-4464
Aug	70	75.5	-5.5	-170.5	-4092		-4092
Sep	70	72	-2	-60	-1440		-1440
Oct	70	64	6	186	4464	4464	
Nov	70	54	16	480	11520	11520	
Dec	70	46.5	23.5	728.5	17484	17484	
Σ =				3082		85044	-11076

Figure 85:

Degree day calculations for Sacramento, CA. Assumed interior temperature of 70°F and average daily temperature used

Cooling Loads - Main Hospital			
	Existing	Proposed	Difference
Annual Heat Gain (Btu)	5.64E+07	5.15E+07	
Annual Heat Gain (kWh)	1.65E+04	1.51E+04	1.44E+03
Total kWh Saved			1.44E+03
Price/kwh			\$ 0.12
Annual Savings			\$ 169.92
Heating Loads - Main Hospital			
	Existing	Proposed	Difference
Annual Heat Loss (Btu)	8.13E+07	7.27E+07	
Annual Heat Loss (kWh)	2.38E+04	2.13E+04	2.52E+03
Total kWh Saved			2.52E+03
Price/kwh			\$ 0.12
Annual Savings			\$ 296.79

Figure 86:

Annual energy savings for cooling and heating loads for a typical patient room within the main hospital wing

Conclusions:

Figure 86 reveals that altering the façade to incorporate a higher thermal performance glazing system will save the South Patient Tower roughly \$467 per year for each patient room. Since the patient tower consists of 174 all-intensive patient rooms, the total savings for the entire year sums up to \$81,208. It is important to note that this cost analysis is purely based on the heat flow rate. Using the degree days method is not completely accurate. In order to obtain a more precise calculation regarding the annual savings for the entire patient tower, each individual room should be modeled within TRACE. Since only a typical room was created in the template section of TRACE with the results interpolated to account for the entire number of patient rooms, the annual savings is a rough estimate. However, it is precise to say that increasing the thermal performance of the glass reduced the heat flow through the curtain wall system for a typical patient room and would ultimately increase the annual savings if the glazing were modified.

Conclusion

The existing structure was altered and two redesigns were completed to determine the effects of implementing a traditional scheme versus a high seismic performance system. This report includes the costs associated with the redesign of the existing two-way concrete flat slab to the proposed one-way slab gravity system with additional moment frames, what cost is associated with moving the structure from a relatively low seismic region to a high seismic region, how much cost is associated with designing for a higher performance criteria and the schedule impacts of the various redesigns.

The two redesigns above were designed to meet certain design criteria set forth in ASCE 41-06, specifically the S-1 “Immediate Occupancy” category. It was found that, although the one-way slab system with fixed base conditions (CA – Fixed Model) weighed slightly less than the existing structure, the structural members part of the lateral resisting system (shear walls and moment frames) were upsized to meet the drift requirements of the S-1 performance levels. The CA – Fixed Model increased the costs by roughly 10% (without the location factor included) when compared to the existing structure with a 3 month increase in construction duration. The one negative aspect associated with this design is that the large moment frames necessary to resist the forces take up a majority of the plenum space. Because the South Patient Tower requires a larger space for the mechanical equipment, this system may require greater coordination among the disciplines involved in the design process. The latter system designed incorporated the use of base isolators (CA – Base Isolation Model) to mitigate the effects of the seismic forces. Because of the damping properties associated with these devices, the implementation of isolators allowed the sizes of the concrete moment frames to remain at levels acceptable to incorporate the mechanical/electrical equipment without much coordination. The CA – Base Isolation Model had relatively the same weight as the base model constructed; however, due to the increased technology associated with the base isolators, the superstructure costs remained relatively the same as the base one-way slab model but with the inclusion of the isolators, the CA – Base Isolation Model increased the costs of the structure by 22% with an additional 4 months of construction time when compared to the base model. Although the costs associated with the CA – Base Isolation Model exceed the CA – Fixed Model, the isolation system remains a viable option due to the decreased moment frame sizes and the overall lower drifts seen during the various time history curves.

These designs were created using a combination of hand calculations, Excel spreadsheets, RAM Concept, ETABS and SAP 2000. Throughout the research and calculations, the design integrated master’s level coursework in the modeling of the structure (AE 597A), earthquake resistant design (AE 538) and building enclosures design/modeling (AE 542).

The costs and schedule durations of the various designs were found using the original schedule and original construction dates provided by Turner construction. Quantity take-offs for the superstructure, data from RS Means and industry professions were utilized in the development of the proposed costs and schedules. This was used to help compare the designs and ultimately determine the feasibility of the designed structures.

Finally, a mechanical/building enclosure breadth was undertaken to determine the viability of altering the existing glazing system to one employing higher thermal performance characteristics. A typical patient room was modeled using TRACE and the cooling/heating loads were determined. After calculating the annual savings associated with implementing the higher performance glazing assembly, it was determined that this modification was feasible when comparing the annual savings to the upfront costs associated with the higher thermal performing wall system.

References

Building Construction Cost Data. Kingston, MA: R.S. Means, 2012. Print.

Committee 318. *Building Code Requirements for Structural Concrete*. [S.l.]: Curran Associates, 2008. Print.

Connor, J. J. *Introduction to Structural Motion Control*. Upper Saddle River, NJ: Prentice Hall Pearson Education, 2003. Print.

FEMA. "Quantification of Building Seismic Performance Factors."
<<http://www.fema.gov/library/viewRecord.do?id=3736>> (April 3, 2012).

Kelly, James M. *Earthquake-resistant Design with Rubber*. London: Springer-Verlag, 1993. Print.

Komodromos, Petros I. *Seismic Isolation for Earthquake-resistant Structures*. Southampton, UK: WIT, 2000. Print

Lepage, Dr. Andres. "Advanced Computer Modeling." AE 597A - Advanced Computer Modeling. The Pennsylvania State University, University Park. 2011. Lecture.

Memari, Dr. Ali M. "Design of Structures with Seismic Isolation." AE 538 - Earthquake Resistant Design. The Pennsylvania State University, University Park. 2011. Lecture.

Minimum Design Loads for Buildings And Other Structures SEI/ASCE 7-05. Amer Society of Civil Engineers, 2005. Print.

Naeim, Farzad. *The Seismic Design Handbook*. New York: Springer Science + Buisness Media, LLC, 2001. Print.

Old Castle. Web. 03 Apr. 2012. <<http://www.oldcastle.com/index.php>>.

Seismic Rehabilitation of Existing Buildings SEI/ASCE 41-06. American Society of Civil Engineers, 2006. Print.

Skinner, R. Ivan, William H. Robinson, and G. H. McVerry. *An Introduction to Seismic Isolation*. Chichester: Wiley, 1993. Print.

University of California. "Pacific Earthquake Engineering Research Center: NGA Database."
<<http://peer.berkeley.edu/nga/>> (April 3, 2011).

Waier, P. R., ed. (2012). *RS Means Building Construction Cost Data 2012*, 70th ed., RS Means Company, Kingston, MA.

Wight, James K., and James G. MacGregor. *Reinforced Concrete: Mechanics and Design*. Upper Saddle River, NJ: Pearson Education, 2009. Print.

Appendices

Appendix A: Typical Plans

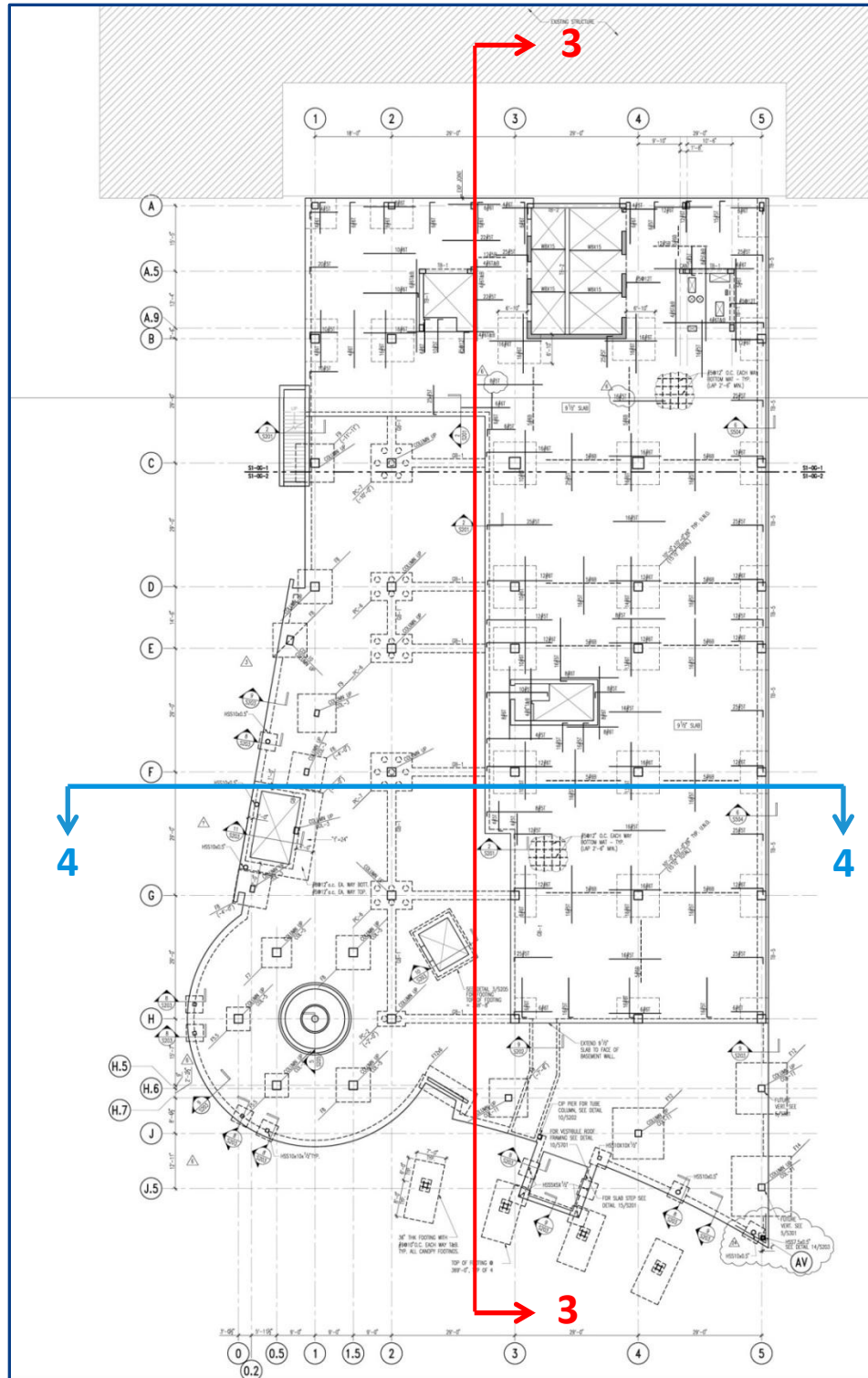

Figure 1:
Ground floor plan (See following figures for sections indicated on the plan)

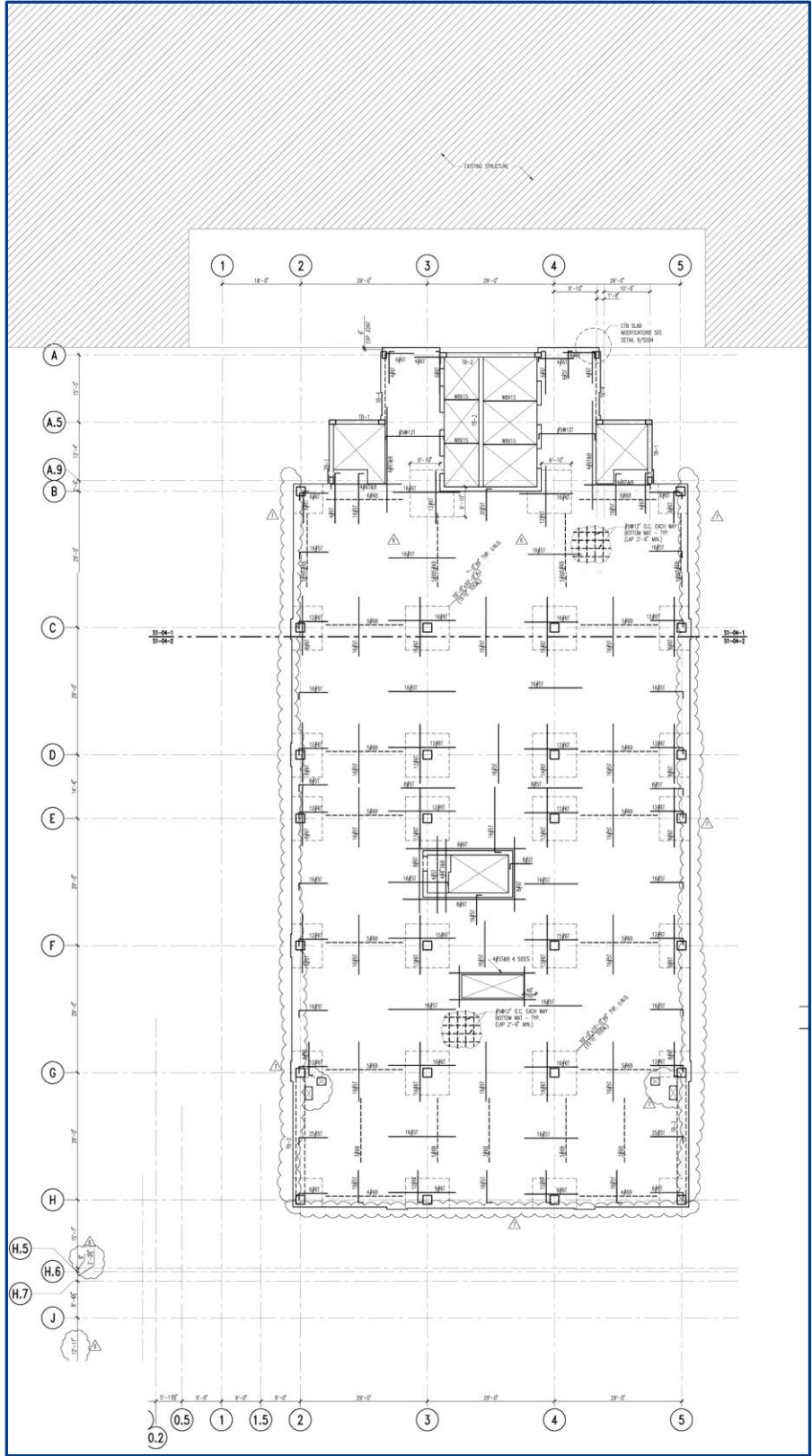

Figure 2:
Typical floor plan (6th – 11th)

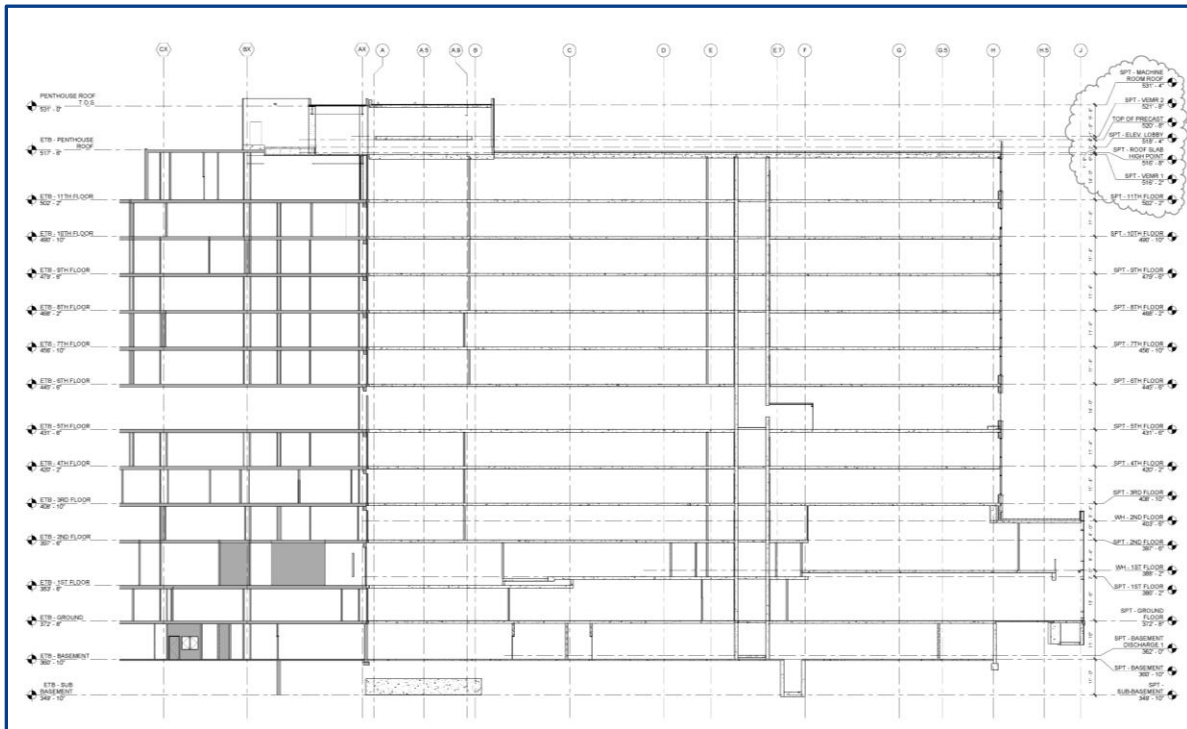

Figure 3:
North – South section cut

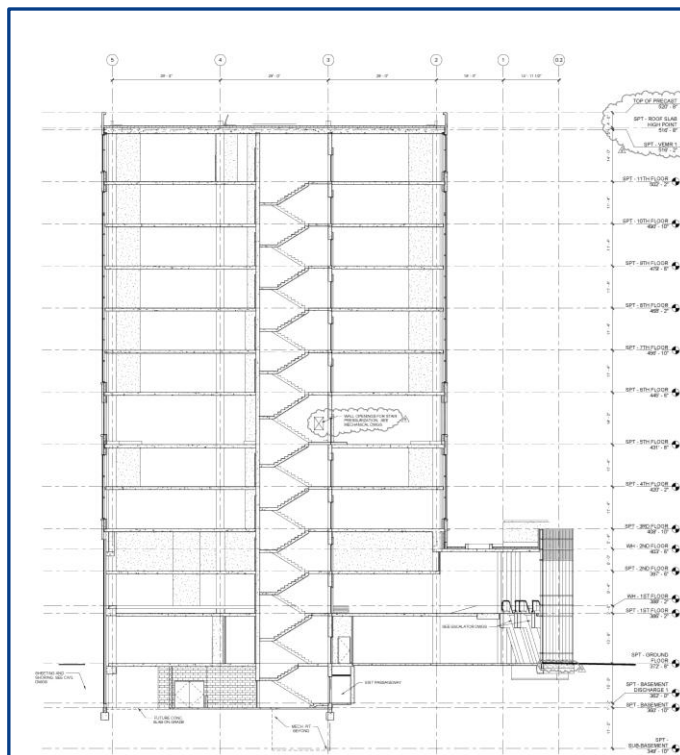

Figure 4:
East – West section cut

Appendix B: Wind Load Calculations

Existing Structure: Falls Church, VA

NATHAN MCGRAW | WIND LOAD CALCS (TECH 3) | PAGE 1 OF 7

SIMPLIFYING ASSUMPTIONS:

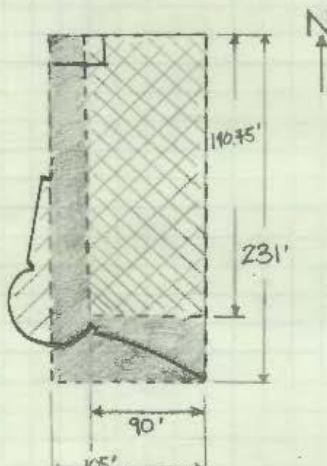

N-S DIRECTION WIND:

$0 \rightarrow 36.17'$
 $L = 231'$
 $B = 105'$
 $36.17' \rightarrow 175'$
 $L = 190.75'$
 $B = 90'$

E-W DIRECTION WIND:

$0 \rightarrow 36.17'$
 $L = 105'$
 $B = 231'$
 $36.17' \rightarrow 175'$
 $L = 90'$
 $B = 190.75'$

USE METHOD 2 SINCE BUILDING WITH SIMPLIFYING ASSUMPTIONS MEETS CRITERIA OF 6.5.1 AND 6.5.2

BASIC WIND SPEED: $V = 90$ mph (FIGURE 6-1C)

WIND DIRECTIONALITY FACTOR: $K_d = 0.85$ (TABLE 6-4)

OCCUPANCY CATEGORY: TYPE IV (TABLE 6-1)

IMPORTANCE FACTOR: $I = 1.15$ (TABLE 6-1)

EXPOSURE CATEGORY: B - Urban/Suburban (§ 6.5.6.3)

TOPOGRAPHIC FACTOR: $K_{zt} = 1.0$ (§ 6.5.7)

VELOCITY PRESSURE COEFFICIENTS: Varies with height \rightarrow See EXCEL Spreadsheet (TABLE 6-3)

VELOCITY PRESSURES: $q_e = 0.00256 K_z K_{zt} K_d V^2 I$ (§ 6.5.10)

GUST EFFECT FACTOR:

$$G_e = \frac{305 (C_{pe})^{0.5}}{H}$$

$$C_{pe} = \frac{100}{A_p} \sum \left(\frac{H}{h_i} \right)^2 \frac{A_i}{[1 + 0.85 (h_i/D_i)]^2}$$

NATHAN MCGRAW | WIND LOAD CALCS (TECH 3) | PAGE 2 OF 7

$AB = (105') \times (231') = 24255 \text{ ft}^2$
 $H = 174' - 4''$

EAST - WEST DIRECTION:

Shear Wall 3:

$h_i = 174' - 4''$
 $D_i = 25'$
 $A_i = (174' - 4'') \times (25') = 4358.25$

$\left(\frac{174.33'}{174.33'}\right)^2 \frac{4358.25}{1 + 0.83 \left(\frac{174.33'}{25'}\right)^2} = 105.38$

Shear Wall 5 & 6:

$h_i = 145'$
 $D_i = 20'$
 $A_i = (145') \times (20') = 2900$

$\left(\frac{174.33'}{145'}\right)^2 \frac{2900}{1 + 0.83 \left(\frac{145'}{20'}\right)^2} = 93.93$

$C_w = \left(\frac{100}{24255}\right) (105.38 + 2(93.93)) = 1.20$

$r_i = \frac{305(1.2)^{0.5}}{174' - 4''} = 2.43 > 1.0 \rightarrow \text{RIGID STRUCTURE}$

NORTH - SOUTH DIRECTION

Shear Wall 1 and 2:

$h_i = 174' - 4''$
 $D_i = 30.75'$
 $A_i = (174' - 4'') \times (30.75') = 5360.75$

$\left(\frac{174.33'}{174.33'}\right)^2 \frac{5360.75}{1 + 0.83 \left(\frac{174.33'}{30.75'}\right)^2} = 193.69$

Shear Wall 4 and 7:

$h_i = 145'$
 $D_i = 10'$
 $A_i = (145') \times (10') = 1450$

$\left(\frac{174.33'}{145'}\right)^2 \frac{1450}{1 + 0.83 \left(\frac{145'}{10'}\right)^2} = 11.94$

NATHAN MCGRAW | WIND LOAD CALCS (TECH 3) | PAGE 3 OF 7

$$C_w = \left(\frac{100}{24255} \right) (2 \times 193.69 + 2 \times 11.94) = 1.69$$

$$n_i = \frac{385 (1.69)^{0.5}}{174^2 - 4^2} = 2.88 > 1.0 \rightarrow \text{RIGID STRUCTURE}$$

\therefore GUST EFFECT FACTOR MAY BE TAKEN AS 0.85 (S6.5.8.1)

ENCLOSURE CLASSIFICATION: Enclosed Building $\rightarrow G C_{pi} = \pm 0.18$ (FIGURE 6-5)

DESIGN WIND PRESSURES: $p = q G C_p - q_i (G C_{pi})$

EXTERNAL PRESSURE COEFFICIENTS:

WALLS:

WINDWARD $\Rightarrow C_p = 0.8$

LEEWARD:

N-S:

$0 \rightarrow 36.17'$: $L/B = 231/105 = 2.2 \Rightarrow C_p = -0.29$

$36.17' \rightarrow 175'$: $L/B = 190.75/90 = 2.1 \Rightarrow C_p = -0.295$

E-W:

$0 \rightarrow 36.17'$: $L/B = 105/231 = 0.45 \Rightarrow C_p = -0.5$

$36.17' \rightarrow 175'$: $L/B = 90/190.75 = 0.47 \Rightarrow C_p = -0.5$

SIDE $\Rightarrow C_p = -0.7$

ROOF: $\theta = 0^\circ$ (Only considered wind for taller tower)

N-S: $h/L = \frac{175'}{190.75'} = 0.917$

E-W: $h/L = \frac{175'}{90'} = 1.9 > 1.0 \Rightarrow \frac{C_p}{\theta \rightarrow h/2} = \frac{-1.3}{-0.7}, -0.18$
 $\frac{C_p}{\theta \rightarrow h/2} = \frac{-0.7}{-0.7}, -0.18$

** Value may be reduced:
 Roof Area = $(190.75')(90') = 17167.5 \text{ ft}^2 \Rightarrow$ Reduction factor = 0.8

DESIGN WIND PRESSURES:

Windward Walls: $p = q G C_p - q_i (G C_{pi})$

Leeward Walls: $p = q_i (G C_p - G C_{pi})$

Side Walls
 Roof

SAMPLE CALC:
 $p = (11.55)(0.85)(0.8) - (23.5)(\pm 0.18) = 7.86 \text{ psf} \pm 4.23 \text{ psf}$

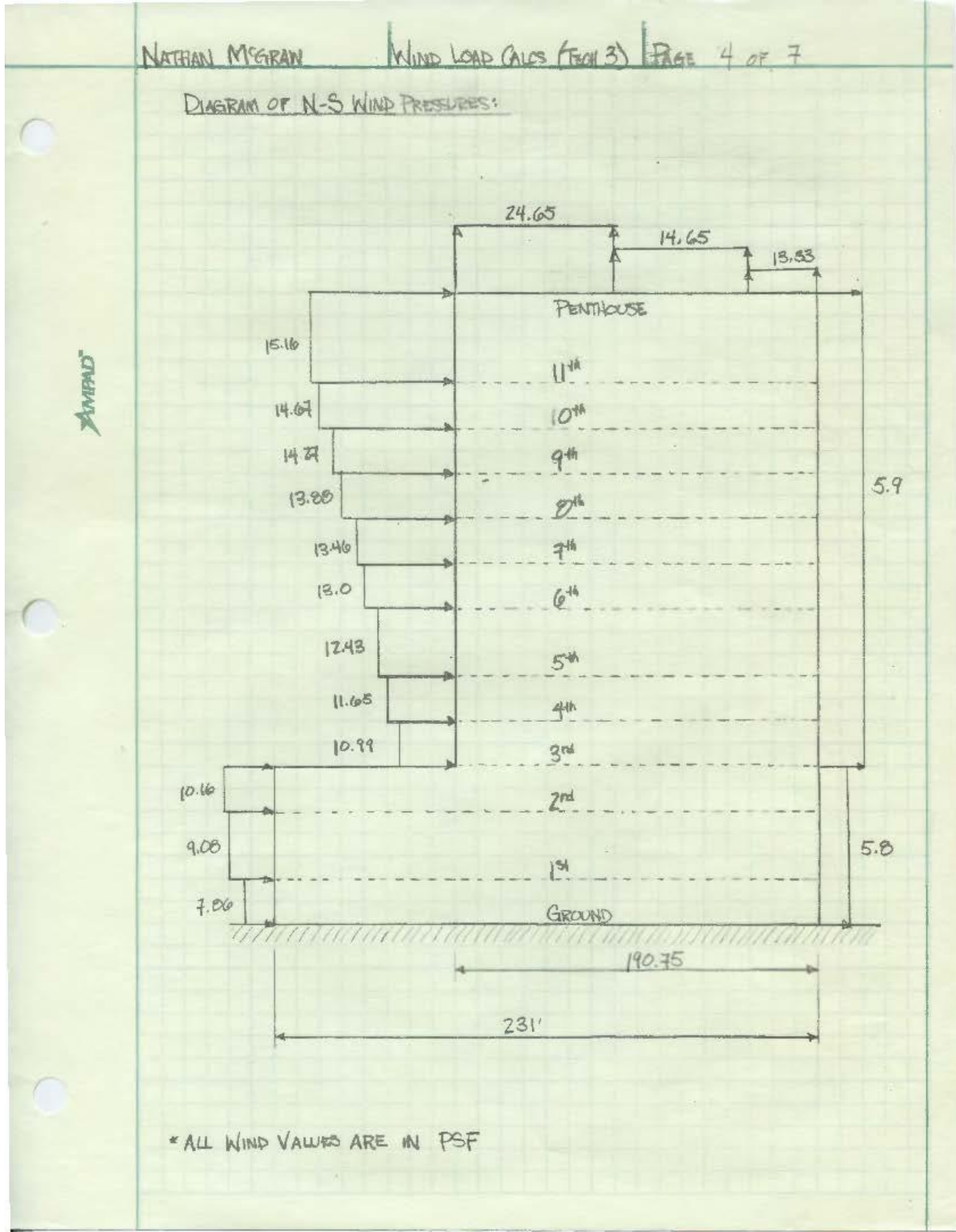

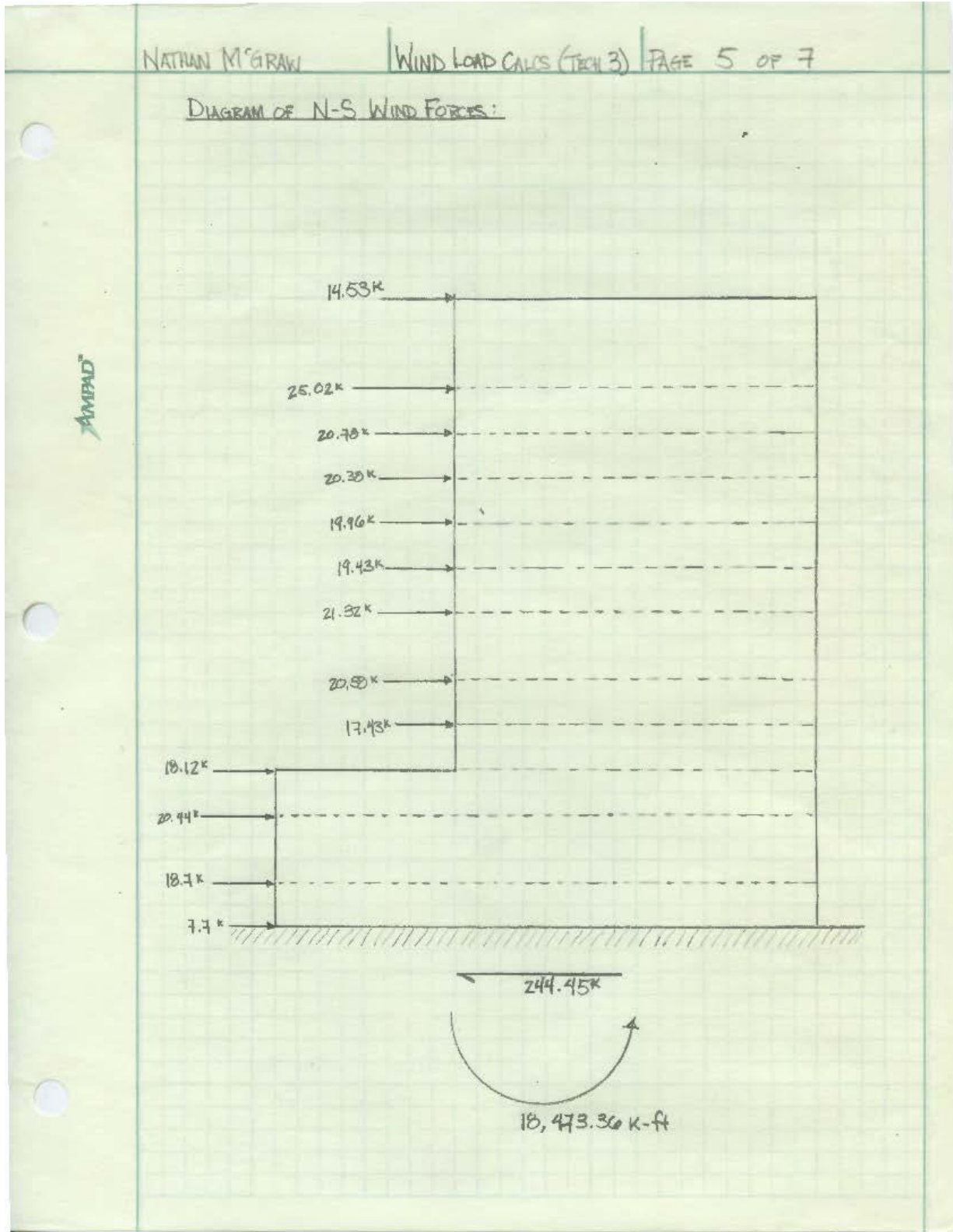

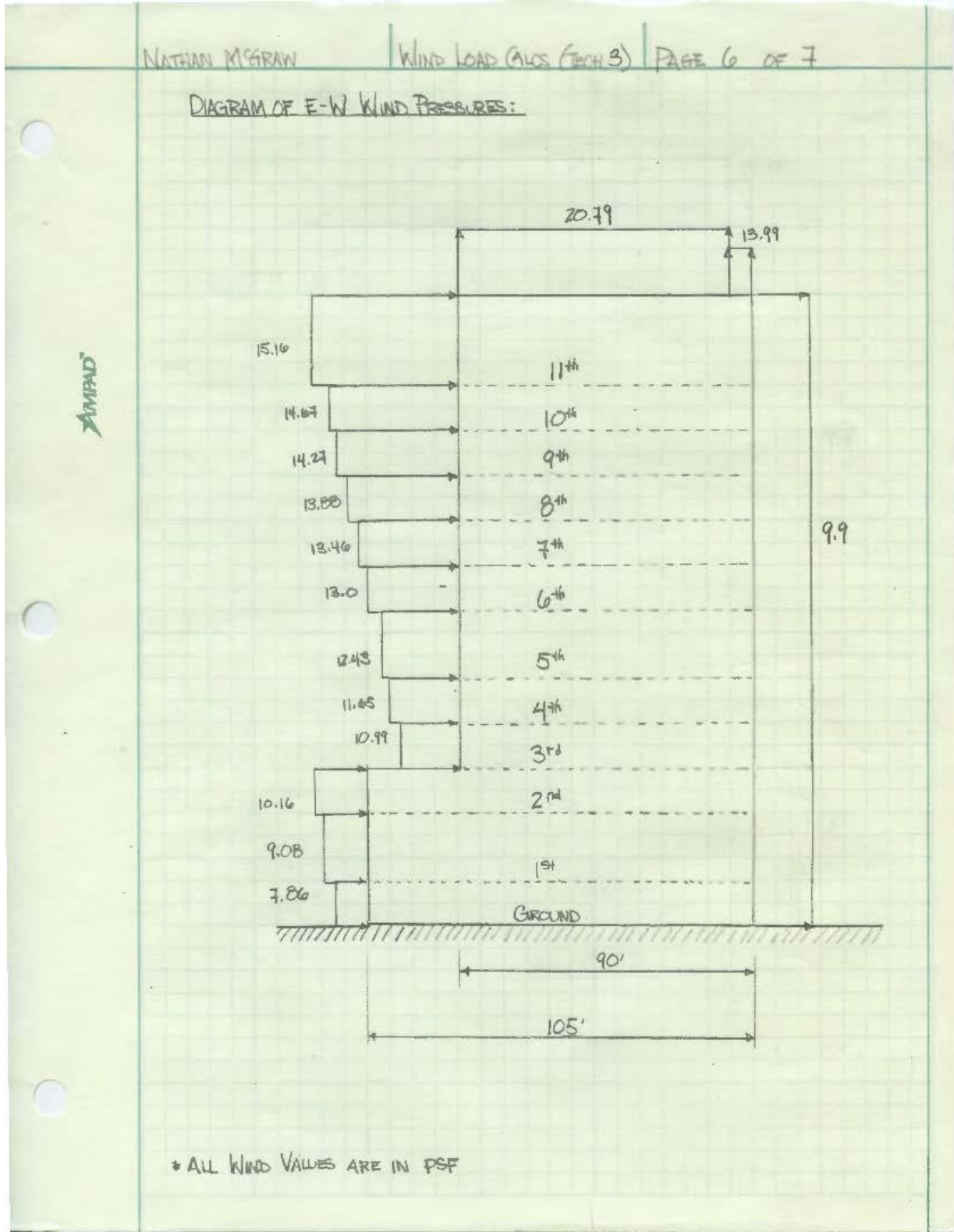

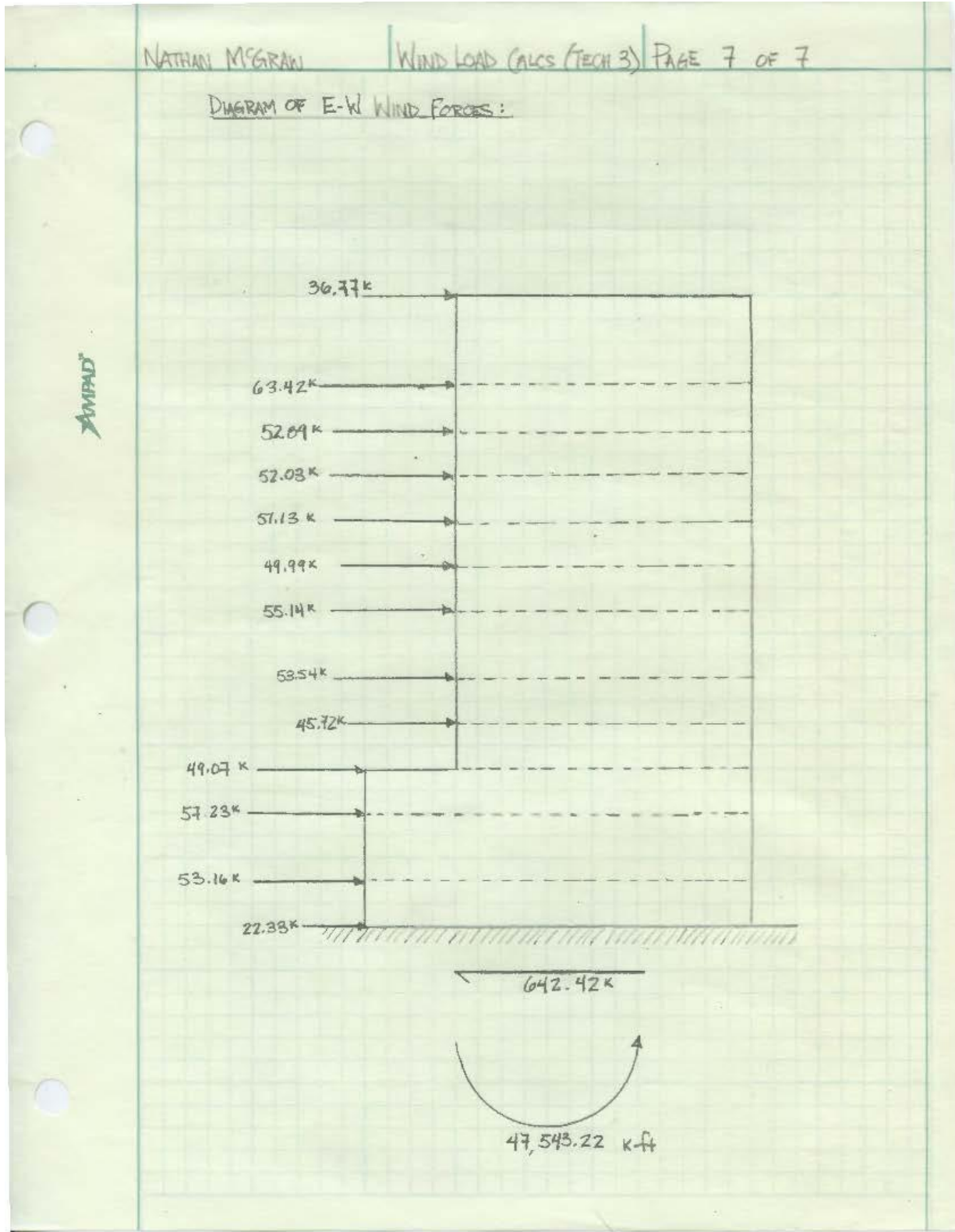

Building Dimensions			
Height Level		N-S Wind	E-W Wind
0' - 36.17'			
B (ft)		105	231
L (ft)		231	105
h (ft)		Not Used	Not Used
36.17' - 175'			
B (ft)		90	190.75
L (ft)		190.75	90
h (ft)		175	175

General Wind Load Design Criteria		
Design Wind Speed	90 mph	ASCE 7-05 (Fig. 6-1C)
Directionality Factor (K_d)	0.85	ASCE 7-05 (Table 6-4)
Importance Factor (I_w)	1.15	ASCE 7-05 (Table 6-1)
Exposure Category	B	ASCE 7-05 (§ 6.5.6.3)
Topographic Factor (K_{zt})	1	ASCE 7-05 (§ 6.5.7)
Internal Pressure Coefficient (GC_{pi})	± 0.18	ASCE 7-05 (Fig. 6-5)

Velocity Pressure Coefficients (K_z) and Velocity Pressures (q_z)			
Level	Elevation (ft)	K_z	q_z (psf)
Ground	0.0	0.57	11.55
1st	10.83	0.57	11.55
2nd	24.83	0.659	13.36
3rd	36.17	0.737	14.94
4th	47.50	0.7975	16.16
5th	58.67	0.845	17.13
6th	72.93	0.902	18.28
7th	84.17	0.943	19.11
8th	95.50	0.9765	19.79
9th	106.83	1.007	20.41
10th	118.17	1.035	20.98
11th	129.5	1.064	21.57
Penthouse	144.83	1.10	22.30
Roof	175.00	1.16	23.51

External Pressure Coefficients (C_p)		
Description	N-S Wind	E-W Wind
0' - 36.17'		
L/B	2.2	0.45
Windward Walls	0.8	
Leeward Walls	-0.29	-0.5
Side Walls	-0.7	
h/L	Not Used	Not Used
Roof - 0 to h/2		
Roof - h/2 to h		
Roof - h to 2h		
Roof - > 2h		
36.17' - 175'		
L/B	2.12	0.472
Windward Walls	0.8	
Leeward Walls	-0.295	-0.5
Side Walls	-0.7	
h/L	0.917	1.9
Roof - 0 to 87.5'	-1.2336	-1.04
Roof - 87.5' to 175'	-0.7332	-0.7
Roof - 175' to 350'	-0.6668	-0.7
Roof - > 350'	-0.6336	-0.7

Floor Level	Wind Forces N-S Direction										Factored Forces (k)
	Elevation (ft)	Tributary Below		Tributary Above		Story Force (k)	Story Shear (k)	Overturning Moment (k-ft)	Overturning Moment (k-ft)	Factored Forces (k)	
		Height (ft)	Area (ft ²)	Height (ft)	Area (ft ²)						
Ground	0.00	N/A	0.00	568.58	5.42	7.77	244.45	0.00	0.00	12.43	
1st	10.83	5.42	568.58	735.00	7.00	18.70	236.68	202.56	202.56	29.93	
2nd	24.83	7.00	735.00	595.35	5.67	20.44	217.98	507.49	507.49	32.70	
3rd	36.17	5.67	595.35	510.00	5.67	18.12	197.54	655.24	655.24	28.99	
4th	47.50	5.67	510.00	502.50	5.58	17.43	179.42	828.11	179.42	27.89	
5th	58.67	5.58	502.50	641.70	7.13	20.58	161.99	1207.50	1207.50	32.93	
6th	72.93	7.13	641.70	505.80	5.62	21.32	141.41	1555.01	1555.01	34.12	
7th	84.17	5.62	505.80	509.85	5.67	19.43	120.09	1635.45	1635.45	31.09	
8th	95.50	5.67	509.85	509.85	5.67	19.96	100.66	1905.75	1905.75	31.93	
9th	106.83	5.67	509.85	510.30	5.67	20.38	80.70	2176.94	2176.94	32.60	
10th	118.17	5.67	510.30	509.85	5.67	20.78	60.32	2455.62	2455.62	33.25	
11th	129.50	5.67	509.85	689.85	7.67	25.02	39.54	3239.55	3239.55	40.03	
Roof	144.83	7.67	689.85	0.00	N/A	14.53	14.53	2104.13	2104.13	23.25	
Total Base Shear = 244.45											
Total Overturning Moment = 18,473.36 k-ft											
Floor Level	Wind Forces E-W Direction										Factored Forces (k)
	Elevation (ft)	Tributary Below		Tributary Above		Story Force (k)	Story Shear (k)	Overturning Moment (k-ft)	Overturning Moment (k-ft)	Factored Forces (k)	
		Height (ft)	Area (ft ²)	Height (ft)	Area (ft ²)						
Ground	0.00	N/A	0.00	1250.87	5.42	22.33	642.42	0.00	0.00	35.72	
1st	10.83	5.42	1250.87	1617.00	7.00	53.16	620.09	575.77	575.77	85.06	
2nd	24.83	7.00	1617.00	1309.77	5.67	57.23	566.93	1420.97	1420.97	91.56	
3rd	36.17	5.67	1309.77	1080.92	5.67	49.07	509.70	1774.84	1774.84	78.51	
4th	47.50	5.67	1080.92	1065.02	5.58	45.72	460.63	2172.07	2172.07	73.16	
5th	58.67	5.58	1065.02	1360.05	7.13	53.54	414.91	3141.15	3141.15	85.66	
6th	72.93	7.13	1360.05	1072.02	5.62	55.14	361.37	4021.21	4021.21	88.22	
7th	84.17	5.62	1072.02	1080.60	5.67	49.99	306.23	4207.29	4207.29	79.98	
8th	95.50	5.67	1080.60	1081.55	5.67	51.13	256.24	4883.29	4883.29	81.81	
9th	106.83	5.67	1081.55	1080.60	5.67	52.03	205.11	5558.62	5558.62	83.25	
10th	118.17	5.67	1080.60	1081.55	5.67	52.89	153.08	6249.54	6249.54	84.62	
11th	129.50	5.67	1080.60	1462.10	7.67	63.42	100.19	8212.81	8212.81	101.47	
Roof	144.83	7.67	1462.10	0.00	N/A	36.77	36.77	5325.66	5325.66	58.83	
Total Base Shear = 642.42											
Total Overturning Moment = 47,543.22 k-ft											

Proposed Structure: University of California – Davis (Sacramento) CA – Base Model

Building Dimensions:

1.)	0' - 36'		N-S Wind		E-W Wind
		B:	105		231
		L:	231		105
		h:	N/A		N/A
1.)	36' - 145'				
		B:	90		190.75
		L:	190.75		90
		h:	145		145

General Wind Load Design Criteria:

Design Wind Speed:	85	(Figure 6-1C)
Directionality Factor (K_d):	0.85	(Table 6-4)
Importance Factor (I_w):	1.15	(Table 6-1)
Exposure Category:	B	(§ 6.5.6.3)
Topographic Factor (K_{zt}):	1.0	(§ 6.5.7)
Intern Pressure Coefficient (GC_{pi}):	± 0.18	(Figure 6-5)

Velocity Pressure Coefficients (K_z) and Velocity Pressures (q_z):			
Level	Elevation (ft)	K_z	q_z (psf)
Penthouse	145	1.10	19.9
11th	129.5	1.06	19.2
10th	118.17	1.04	18.7
9th	106.83	1.01	18.2
8th	95.5	0.98	17.7
7th	84.17	0.94	17.0
6th	72.93	0.90	16.3
5th	58.67	0.84	15.3
4th	47.5	0.80	14.4
3rd	36.17	0.74	13.3
2nd	24.83	0.66	11.9
1st	10.83	0.57	10.3
Ground	0	0.57	10.3

Gust Effect Factor: Due to Flexible Diaphragm (frequency < 1 Hz)

§ 6.5.8.2

g_Q :	3.4
g_V :	3.4
α :	7
z_g (ft):	1200
\hat{a} :	0.143
\hat{b} :	0.84
\bar{a} :	0.25
\bar{b} :	0.45
c :	0.3
l (ft):	320
ϵ :	0.333
z_{min} (ft)*:	30
max:	87

n_1 :	$100/H =$	0.690	(Average Value from C6-17)	*Used for Calculations
n_1 :	$75/H =$	0.517	(Lower Bound from C6-18)	
g_R :	4.10		(Eqn. 6-9)	
l_z :	0.255		(Eqn. 6-5)	
L_z :	442.1		(Eqn. 6-7)	
V_z :	71.48		(Eqn. 6-14)	
N_1 :	4.26		(Eqn. 6-12)	
R_n :	0.0561		(Eqn. 6-11)	
β :	0.01		(Assumed, Conservative for Concrete Shear Walls)	

North-South

East-West

B:	90
L:	190.75
h:	145
η_n :	6.43
R_n :	0.143
η_B :	3.99
R_B :	0.219
η_L :	28.34
R_L :	0.035
R:	0.310
Q:	0.838
G_f :	0.880

B:	190.75
L:	90
h:	145
η_n :	6.43
R_n :	0.143
η_B :	8.47
R_B :	0.111
η_L :	13.37
R_L :	0.072
R:	0.224
Q:	0.809
G_f :	0.844

External Pressure Coefficients (C_p):

	N-S Wind	E-W Wind
0' - 36'		
L/B:	2.20	0.45
Windward Wall:	0.8	
Leeward Wall:	-0.29	-0.5
Side Wall:	-0.7	
36' - 145'		
L/B:	2.12	0.47
Windward Wall:	0.8	
Leeward Wall:	-0.294	-0.5
Side Wall:	-0.7	
h/L:	0.760	1.611
Roof: 0 - 72.5'	-1.108	-1.04
Roof: 72.5 to 145'	-0.796	-1.04
Roof: 145 to 290'	-0.604	-0.7
Roof: > 290'	-0.508	-0.7

Appendix C: Seismic Load Calculations

Existing Structure: Falls Church, VA

NATHAN MCGRAW | SEISMIC LOAD CALCS (TECH 3) | PAGE 1 OF 5

SITE CLASS: D (Given on Sheet SO-01)

MAPPED SHORT PERIOD SPECTRAL RESPONSE ACCELERATION: $S_s = 0.154$
 MAPPED 1-SECOND PERIOD SPECTRAL RESPONSE ACCELERATION: $S_1 = 0.051$
 (* USED USGS WEB APPLICATION TO OBTAIN THESE VALUES)

IMPORTANCE FACTOR: Category IV (TABLE 1.1) \Rightarrow SEISMIC IMPORTANCE FACTOR = 1.5 (TABLE 11.5.1)

SITE COEFFICIENT, F_a : $F_a = 1.6$ (TABLE 11.4-1)

SITE COEFFICIENT, F_v : $F_v = 2.4$

DESIGN SPECTRAL ACCELERATION PARAMETERS (§ 11.4-4):

$S_{DS} = \frac{2}{3} S_{MS}$
 $S_{D1} = \frac{2}{3} S_{M1}$

ADJUSTED MAXIMUM CONSIDERED EQ (§ 11.4-3):

$S_{MS} = F_a S_s = (1.6)(0.154) = 0.2464$
 $S_{M1} = F_v S_1 = (2.4)(0.051) = 0.1224$
 $S_{DS} = \frac{2}{3} (0.2464) = 0.1643$
 $S_{D1} = \frac{2}{3} (0.1224) = 0.0816$

SEISMIC DESIGN CATEGORY:

Short Period Response \Rightarrow SDC = A (TABLE 11.6-1)
 1-Second Period Response \Rightarrow SDC = C (TABLE 11.6-2)

* SINCE DIFFERENT SEISMIC DESIGN CATEGORIES, DESIGN TO WORST CASE SEISMIC DESIGN CATEGORY = C

PERMITTED ANALYTICAL PROCEDURE: Equivalent Lateral Force Analysis permitted (TABLE 12.6-1)

RESPONSE MODIFICATION COEFFICIENT: TABLE 12.2-1

$R = 4\frac{1}{2} \Rightarrow$ Shear Wall-Frame Interactive System with Ordinary Reinforced Concrete Moment Frames and Ordinary Reinforced Concrete Shear Walls
 $C_d = 4.0 \Rightarrow$ USED TO GET CODE DISPLACEMENTS FROM ELASTIC MODEL

NATHAN MCGRAW | SEISMIC LOAD CALCS (TECH 3) | PAGE 2 OF 5

APPROXIMATE FUNDAMENTAL PERIODS: § 12.8.2.1 AND TABLE 12.8-2

$$T_a = C_t h_n^x$$

$C_t = 0.02$
 $x = 0.75$ "ALL OTHER STRUCTURAL SYSTEMS"

$$T_a = (0.02)(145')^{0.75}$$

$$T_a = 0.8357 \text{ sec.} \quad C_u = 1.7 \text{ (TABLE 12.8-1)}$$

SEISMIC RESPONSE COEFFICIENT: § 12.8.1.1

$$C_s = \begin{cases} \frac{S_{DS}}{(R/I)} \\ \frac{S_{D1}}{T(R/I)} \\ \min \frac{S_{D1} T_L}{T^2 (R/I)} \end{cases} \geq 0.01$$

$T_L = 8 \text{ sec. (FIGURE 22-15)}$
 $T = C_u T_a$
 $T = 1.7(0.8357) = 1.4207$

$$C_s = \begin{cases} \frac{(0.1643)}{(4.5/1.5)} = 0.0548 \\ \frac{(0.0816)}{(1.4207)(4.5/1.5)} = 0.019145 \Rightarrow C_s = 0.019145 > 0.01 \therefore \text{OK} \checkmark \\ \min \frac{(0.0816)(8)}{(1.4207)^2 (4.5/1.5)} = 0.1078 \end{cases}$$

ETABS PERIOD:

RIGID DIAPHRAGM MODEL:

$T_x = 2.943 \text{ SEC}$
 $T_y = 2.112 \text{ SEC}$
 $T_z = 1.729 \text{ SEC}$

TWO-WAY SLAB SYSTEM MODELED AS SHELL ELEMENT:

$T_x = 2.0213 \text{ SEC}$
 $T_y = 1.5947 \text{ SEC}$
 $T_z = 1.4134 \text{ SEC}$

* BECAUSE T_x AND T_y ARE BOTH GREATER THAN THE UPPER LIMIT ($C_u T_a$), T OF 1.4207 SEC WAS USED TO CALCULATE THE FORCES IN BOTH THE X AND Y DIRECTIONS.

NATHAN MCGRAW | SEISMIC LOAD (AUG TECH 13) | PAGE 3 OF 5

WEIGHT CALCULATIONS:

FAÇADE:

5 1/2" Concrete + 1/2" Thin Brick Face = (6 1/2" / 12") (150 lb/ft³) = 75 psf

2" Air space ⇒ 0 psf

4" Glass Fiber Insulation with Vapor Barrier = 1 1/2 psf x 4" = 6 psf

3 5/8" Metal Studs = 1 psf

FAÇADE TOTAL WEIGHT = 75 + 6 + 1 = 82 psf

MAIN ROOF:

12" Concrete = (12 1/2" / 12") (150 lb/ft³) = 150 psf

Roof Membrane = 2 psf

5/8" Roof Board = 1/2 psf x 5/8" = 0.9375 psf

MAIN ROOF TOTAL WEIGHT = 150 + 2 + 0.9375 = 152.9375 psf

TYPICAL ROOF:

9 1/2" Concrete = (9 1/2" / 12") (150 lb/ft³) = 118.75 psf

6" Rigid Insulation = 1 1/2 psf x 6" = 9 psf

Roof Membrane = 2 psf

TYPICAL ROOF TOTAL WEIGHT = 118.75 + 9 + 2 = 129.75 psf

VEGETATED ROOF SYSTEM:

EXTRUDED - Polystyrene Roof Insulation = (1.0 lb/ft³) (6 1/2") = 0.9 psf

Roof Pavers = 25 psf

VEGETATED SYSTEM = 30 psf

VEGETATED ROOF TOTAL WEIGHT = 0.9 + 25 + 30 = 55.9 psf

* EXCEL CONTAINS TOTAL BUILDING WEIGHT WITH FLOOR BY FLOOR BREAKDOWN

NATHAN MCGRAW | SEISMIC LOAD CALCS (TRCH 3) | PAGE 4 OF 5

BASE SHEAR:

$$V = C_s W$$

W = weight of building (calculated in spreadsheet)

$$C_{s N-S} = C_{s E-W} = 0.01795$$

$$V = (0.01795)(39,026,339 \text{ K})$$

$$V = 747.16 \text{ K}$$

(STRUCTURAL DRAWINGS = 700 K → 6.74% DIFFERENCE ✓
 * DIFFERENCE DUE TO DIFFERENT WEIGHT CALCS AND DIFFERENT S_s AND S_1 VALUES

STORY FORCES:

$$F_x = C_{vx} V$$

$$C_{vx} = \frac{W_x h_x^K}{\sum W_i h_i^K}$$

W_x = weight of each story
 h_x = height of story above grade
 $K = 1 + \frac{N-0.5}{2}$ ($1 \leq K \leq 2$)

$$K = 1 + \frac{1.4207 - 0.5}{2} = 1.5076$$

* CALCULATED THE STORY FORCES AND OVERTURNING MOMENTS IN AN EXCEL SPREADSHEET

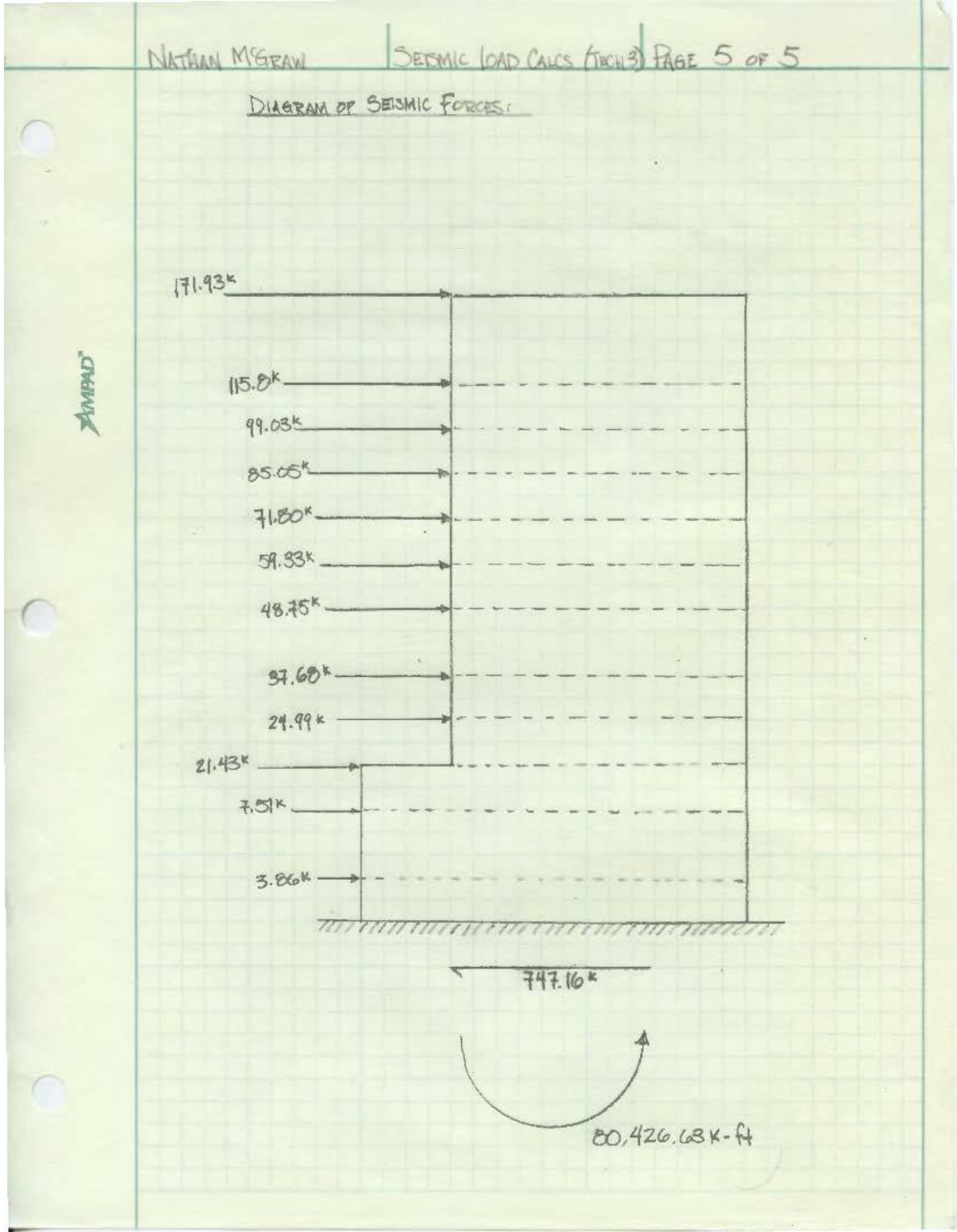

Proposed Structure: University of California – Davis (Sacramento) CA – Base Model

Superimposed Dead Loads	
Description	Load
Floors	20 psf
Standard Roof	20 psf
Main Roof	20 psf

Weight Per Level		
Level	Area (ft ²)	Weight (kips)
Ground	25513	N/A
1st	25513	3855
2nd	11649	2732
3rd	17958	3186
4th	16571	2911
5th	16571	3013
6th	16571	3013
7th	16571	2911
8th	16571	2911
9th	16571	2911
10th	16571	2911
11th	16571	2999
Penthouse/Roof	16571	3831
		37184

Slab Weights			
Level	Slab Area (ft ²)	Beam Area (ft ²)	Weight (kips)
Ground	10268	4904	N/A
1st	10268	4904	2276
2nd	4450	4904	1403
3rd	6501	4904	1711
4th	6501	4904	1711
5th	6501	4904	1711
6th	6501	4904	1711
7th	6501	4904	1711
8th	6501	4904	1711
9th	6501	4904	1711
10th	6501	4904	1711
11th	6501	4904	1711
Penthouse/Roof	6501	4904	1711
			20787

Superimposed Dead Load			
Level	Slab Area (ft²)	Roof Area (ft²)	Weight (kips)
Ground	25611	0	N/A
1st	25611	0	512
2nd	11649	0	233
3rd	16571	9040	512
4th	16571	0	331
5th	16571	0	331
6th	16571	0	331
7th	16571	0	331
8th	16571	0	331
9th	16571	0	331
10th	16571	0	331
11th	16571	0	331
Penthouse/Roof	0	16571	331
			4240

Shear Wall Weights		
Level	Volume (ft³)	Weight (kips)
1st	2022.9	303.4
2nd	2077.6	311.6
3rd	1858.8	278.8
4th	1858.8	278.8
5th	2077.6	311.6
6th	2077.6	311.6
7th	1858.8	278.8
8th	1858.8	278.8
9th	1858.8	278.8
10th	1858.8	278.8
11th	2186.9	328.0
Penthouse/Roof	1257.5	188.6
		3427.9

Curtain Wall Weights						
Level	Tributary Height (ft)	Length (ft)	With (ft)	Total Perimeter (ft)	Area (ft ²)	Weight (kips)
1st	12.333	231	105	672	8288.0	485.3
2nd	12.667	231	105	672	8512.2	498.4
3rd	11.333	231	105	672	7615.8	445.9
4th	11.333	190.75	90	561.5	6363.5	372.6
5th	12.667	190.75	90	561.5	7112.5	416.4
6th	12.667	190.75	90	561.5	7112.5	416.4
7th	11.333	190.75	90	561.5	6363.5	372.6
8th	11.333	190.75	90	561.5	6363.5	372.6
9th	11.333	190.75	90	561.5	6363.5	372.6
10th	11.333	190.75	90	561.5	6363.5	372.6
11th	11.333	190.75	90	561.5	6363.5	372.6
Penthouse/Roof	7.667	190.75	90	561.5	4305.0	252.1
						4750.0

Column Weights									
Level	24"x24"	26"x26"	12"x18"	12"x24"	28"x28"	18"x18"	18"x24"	Volume (ft ³)	Weight (kips)
1st - Below	28	0	8	1	4	1	1	1854	278
1st - Top	28	1	8	1	3	1	1		
2nd - Below	28	1	8	1	3	1	1	1906	286
2nd - Top	28	1	8	1	3	1	1		
3rd - Below	28	1	8	1	3	1	1	1587	238
3rd - Top	27	0	6	0	2	0	0		
4th - Below	27	0	6	0	2	0	0	1449	217
4th - Top	27	0	6	0	2	0	0		
5th - Below	27	0	6	0	2	0	0	1620	243
5th - Top	27	0	6	0	2	0	0		
6th - Below	27	0	6	0	2	0	0	1620	243
6th - Top	27	0	6	0	2	0	0		
7th - Below	27	0	6	0	2	0	0	1449	217
7th - Top	27	0	6	0	2	0	0		
8th - Below	27	0	6	0	2	0	0	1449	217
8th - Top	27	0	6	0	2	0	0		
9th - Below	27	0	6	0	2	0	0	1449	217
9th - Top	27	0	6	0	2	0	0		
10th - Below	27	0	6	0	2	0	0	1449	217
10th - Top	27	0	6	0	2	0	0		
11th - Below	27	0	6	0	2	0	0	1705	256
11th - Top	27	0	6	0	2	0	0		
Penthouse/Roof Below	27	0	6	0	2	0	0	980	147
									2778

Sacramento CA

Latitude: 38.55

Longitude: -121.74

Site Class: D

$S_s = 0.900$ *USGS Web Application (Confirmed with Figure 22-1 of ASCE 7-05)

$S_1 = 0.325$ *USGS Web Application (Confirmed with Figure 22-2 of ASCE 7-05)

$T_L = 8$ sec. (Confirmed with Figure 22-15 of ASCE 7-05)

Occupancy Category = IV (Table 1.1)

Importance Factor = 1.5 (Table 11.5.1)

Site Coefficient, $F_a = 1.0$ (Table 11.4-1)

Site Coefficient, $F_v = 1.5$ (Table 11.4-2)

$S_{MS} = 0.90$ $F_a \cdot S_s$ (11.4-1)

$S_{M1} = 0.49$ $F_v \cdot S_1$ (11.4-2)

$S_{DS} = 0.600$ $(2/3)S_{MS}$ (11.4-3)

$S_{D1} = 0.325$ $(2/3)S_{M1}$ (11.4-4)

Short Period SDC = D (Table 11.6-1)

1.0-s Period SDC = D (Table 11.6-2)

Permitted Analytical Procedure: Modal Response Spectrum Analysis (Table 12.6-1)
Seismic Response History Procedure (Table 12.6-1)

Response Modification Coefficient = 6.5 (Table 12.2-1)

Amplification Factor = 5.0 (Table 12.2-1)

Approximate Fundamental Period:

$T_a = C_t h_n^x$

$C_t = 0.02$ (Table 12.8-2)

$x = 0.75$ (Table 12.8-2)

$h_n = 145$ ft.

$T_a = 0.8357$ sec.

$C_u = 1.4$ (Table 12.8-1)

$C_u T_a = 1.17$ sec. (Upper Limit on Calculated Period)

Seismic Response Coefficient:

$$C_s = \begin{cases} \frac{S_{DS}}{(R/I)} = \frac{0.6}{(4.5/1.5)} = 0.138 & \text{(Eqn. 12.8-2)} \\ \frac{S_{D1}}{T(R/I)} = \frac{0.325}{(1.17)(4.5/1.5)} = 0.064 \geq 0.01 & \text{(Eqn. 12.8-3)} \\ \min \frac{S_{D1}T_L}{T^2(R/I)} = \frac{(0.325)(8)}{(1.17)^2(4.5/1.5)} = 0.438 & \text{(Eqn. 12.8-4)} \end{cases}$$

For $S_1 \geq 0.6g$:Apply: **No**

$$C_s \geq \frac{0.5S_{DS}}{(R/I)} = \frac{1.333}{(4.5/1.5)} = 0.069 \quad \text{(Eqn. 12.8-6)}$$

$$C_s = 0.064$$

Base Shear: $V = C_s W$

$$W = 37,184 \text{ kips}$$

$$V = C_s W = 2,384 \text{ kips}$$

NATHAN MCGRAW	OVERTURNING MOMENT	FINAL REPORT
---------------	--------------------	--------------

CONTROLLING BASE OVERTURNING MOMENT:

The diagram shows a rectangular cross-section of a wall or foundation. The total width is labeled as $2L$. The height is H . A vertical load W is applied at the top center. A horizontal load is applied at the top left corner. The base is divided into two segments of length L .

$$M_{RESISTING} = \frac{1}{2} \left| \frac{B}{L} \right| \times W = \frac{1}{2} \left| \frac{90'}{190.75'} \right| = 45' \times W$$

CONTROLLING LOAD COMBINATION: $(0.9 - 0.2SDS)D + pQ_e + 1.6H$

§12.4.2.3 (ASCE 7-05)

$$M_{RESISTING} = (0.9 - 0.2SDS)D$$

$$M_{OVERTURNING} = pQ_e$$

$$M_{RESISTING} = (0.9 - 0.2(0.6)) (37,184 \text{ KIPS}) (45') = (45) (0.78) (37,184)$$

$$M_{RESISTING} = 1,305,158' \text{K} = 1,305,158' \text{K}$$

$$M_{OVERTURNING} = (1.3) (214,867' \text{K}) = 279,327' \text{K}$$

$\frac{2}{3} M_R > M_o$

$$\frac{2}{3} (1,305,158) > 279,327$$

$870,105' \text{K} > 279,327' \text{K} \therefore \text{OK} \checkmark$

Appendix D: Gravity Redesign Calculations

NATHAN MCGRAW GRAVITY REDESIGN - FINAL

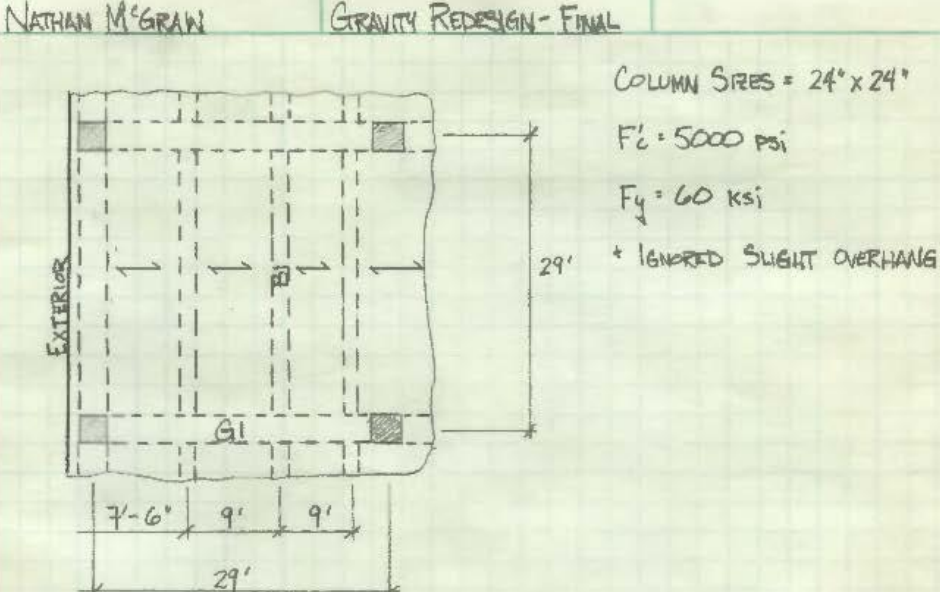

COLUMN SIZES = 24" x 24"
 $F_c = 5000$ psi
 $F_y = 60$ ksi
 * IGNORED SLIGHT OVERHANG

MINIMUM SLAB THICKNESS: PER TABLE 9.5(a) ACI 318-08

EXTERIOR BAY = $\frac{l}{24} = \frac{7.5'(12")}{24} = 3.75"$

INTERIOR BAY = $\frac{l}{20} = \frac{9'(12")}{20} = 3.86"$

\therefore USE A SLAB THICKNESS $t = 5.0"$ (FOR TWO-HOUR FIRE RATING)

$W_D = (5\frac{1}{2}" \times 150 \text{ lb/ft}^3) = 62.5$ psf + 20 psf SUPERIMPOSED = 82.5 psf
 $W_L = 60$ psf + 20 psf PARTITION = 80 psf

$W_U = 1.2(82.5) + 1.6(80) = 227$ psf

SLAB DESIGN:

ASSUME TENSION-CONTROLLED SECTION $\rightarrow \phi = 0.9$

$W_L = 80$ psf $\leq 3(82.5) = 247.5$ psf \therefore CAN USE ACI MOMENT COEFFICIENTS

BEAM WIDTH = 12"

EXTERIOR BAY:

INTERIOR BAY:

$ln_{avg} = \frac{72 + 96}{(2)(12')} = 7'-0"$

FIRST INTERIOR SUPPORT:

$$M_u = \frac{-w_u l_n^2}{10} = \frac{-(227)(7')^2}{10} (1' \text{ WIDTH}) = 1112.3 \text{ lb-ft/width} = 1.1123 \text{ K-ft/ft}$$

SECOND INTERIOR SUPPORT:

$$M_u = \frac{-w_u l_n^2}{11} = \frac{-(227)(8')^2}{11} (1' \text{ WIDTH}) = 1320.7 \text{ lb-ft/width} = 1.321 \text{ K-ft/ft}$$

MAXIMUM NEGATIVE MOMENT (DESIGN) = $M_u = 1.321 \text{ K-ft/ft}$

REINFORCEMENT (*ASSUME $j_d = 0.95d$) $d = h - c_{cover} - d_b/2 = 5 - 3/4 - 0.5/2 = 4"$

$$A_s \geq \frac{M_u}{\phi f_y (d - a/2)} \approx \frac{M_u}{\phi f_y (j_d)} = \frac{(1.321)(12'')}{0.9(60)(0.95 \times 4)} = 0.07725 \text{ in}^2/\text{FT}$$

$$a = \frac{A_s f_y}{0.85 f'_c b} = \frac{(0.07725)(60)}{0.85(5)(12'')} = 0.0909'' \Rightarrow \phi = 0.9$$

$$A_s \geq \frac{(1.321)(12'')}{(0.9)(60)(4 - 0.09/2)} = 0.0742 \text{ in}^2/\text{FT}$$

$$p = \frac{A_s/f_t}{bd} = \frac{0.0742}{12'' \times 4''} = 0.00155$$

SHEAR CHECK:

SHEAR AT EXTERIOR SUPPORT FACE OF THE FIRST INTERIOR SUPPORT

$$V_u = \frac{1.15 W_u l_n}{2} = \frac{1.15 (227) (6')}{2} = 783.15 \text{ lb/FT WIDTH OF SLAB}$$

$$\phi V_c = 0.75 (2 \lambda \sqrt{f_c'} b_w d) = 0.75 (2) (10) \sqrt{5000} (12") (4") = 5091 \text{ lb/FT WIDTH}$$

$$\phi V_c > V_u \Rightarrow \therefore \text{OK}$$

DESIGN OF REINFORCEMENT:

	EXT. SUPPORT	EXT. MIDSPAN	1 st INT. SUPPORT	INT. MIDSPAN	2 nd INT. SUPPORT
1. l_n (ft)	6	6	7	8	8
2. $W_u l_n$ (k-ft)	8.172	8.172	11.123	14.528	14.528
3. M COEFFICIENT	-1/24	1/14	-1/10	1/16	-1/11
4. M_u (k-ft/ft)	0.3405	0.5837	1.1123	0.908	1.3207
5. A_s REQ (in ² /ft)	0.0227	0.0309	0.0742	0.0606	0.0881
6. A_s MIN (in ² /ft)	0.108	0.108	0.108	0.108	0.108
7. BARS	No. 4 @ 12" →				
8. FINAL A_s (in ² /ft)	0.2 →				

$$\text{STEP 5 FACTOR} = \frac{0.0742}{1.1123} = 0.067$$

$$A_{s \text{ MIN}} = 0.0018 (12") (5") = 0.108$$

TRANSVERSE DIRECTION:

$$A_{s \text{ MIN } S-T} = 0.0018 (12") (5") = 0.108 \Rightarrow \text{USE \#4'S}$$

$$\begin{aligned} \text{MAXIMUM SPACING} &\leq 5h = 5(5) = 25" \\ &\leq 18" \quad \therefore \text{OK} \end{aligned}$$

SPACING:

$$S = 15 (46000/f_s) - 2.5 C_c \leq 12 (40000/f_s) \quad f_s = 2/3 f_y = 46000$$

$$S = 15 (40000/40000) - 2.5 (0.75) \leq 12 (40000/40000)$$

$$S = 13.125 \leq 12 \quad \therefore \text{USE 12" SPACING}$$

SLAB DETAILS:

5" SLAB

No. 4 BARS AT 12" FOR TOP/BOTTOM

No. 4 BARS AT 18" FOR TRANSVERSE DIRECTION

BEAM:

$$b = 12''$$

$$h = 24'' \text{ (FOR CONSTRUCTION PURPOSES)}$$

$$h = 1/12 - 1/18$$

$$h = \frac{(29')}{12} = 29'' - \frac{(29')}{18} = 19.3'' \therefore 24'' \text{ OK}$$

$$W_{\text{BEAM}} = \frac{(24'' - 5'')(12'')(150 \text{ lb/ft}^3)}{144} = 237.5 \text{ lb/ft} = 0.2375 \text{ K/ft}$$

$$W_{\text{SLAB + SI}} = (62.5 + 20)(9') = 742.5 \text{ lb/ft} = 0.742 \text{ K/ft}$$

$$LL_r = 0.25 + \frac{15}{\sqrt{(29 \times 9 \times 2)}} = 0.907$$

$$= 522 > 400 \therefore \text{OK}$$

$$W_L = (0.907)(80 \text{ psf})(9') = 653.04 \text{ lb/ft} = 0.653 \text{ K/ft}$$

$$W_U = 1.2(0.2375 + 0.742) + 1.6(0.653) = 2.22 \text{ K/ft}$$

$$M_u^+ = \frac{W_L l^2}{16} = \frac{(2.22)(29' - 2')^2}{16} = 101 \text{ K}$$

$$M_u^- = \frac{-W_L l^2}{11} = \frac{-(2.22)(29' - 2')^2}{11} = -147 \text{ K}$$

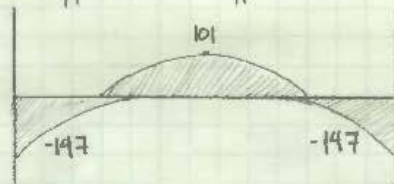
AT MIDSPAN: $M_u = 101 \text{ K}$

$$A_s = \frac{M_u}{4d} = \frac{101}{4(21'')} = 1.20 \text{ in}^2$$

$$\text{TR4 (3) \# 6's : } A_s = (3)(0.42) = 1.32 \text{ in}^2$$

$$p = 0.125\% \Rightarrow p = \frac{1.32}{(12)(21)} = 0.00524 \therefore \text{OK}$$

$$f'_c = 4000 \text{ psi} \therefore \text{OK}$$

$$d = 24'' - 1.5'' - \frac{1}{2}'' - \frac{0.75}{2}'' = 21.625''$$

$\leftarrow \frac{1}{2} d_b$ $\rightarrow \frac{1}{2} d_b$
 # 4 STIRRUP

$$b_{eff} = \begin{cases} \frac{1}{4} \text{ SPAN LENGTH} = \frac{1}{4}(29')(12'') = 87'' + \text{CONTROLS} \\ b_w + 16h_f = 12'' + 16(5'') = 92'' \\ \text{MIN } b_w + 2(\frac{1}{2} \text{ CLR DISTANCE}) = 12'' + 2(\frac{1}{2}(9' - 1'))(12'') = 108'' \end{cases}$$

$$M_u - \text{TEM} \cdot \phi 0.05 f_c' b_{eff} h_f (d - h_f/2) = \frac{(0.9)(0.05)(5)(87)(5)(21.6 - 5/2)}{12}$$

$$M_u - \text{TEM} = 2051.8 \text{ 'K} > M_u \Rightarrow \text{TREAT AS RECTANGULAR BEAM}$$

$$a = \frac{A_s f_y}{0.05 f_c' b} = \frac{(1.32)(60)}{0.05(5)(12)} = 1.55''$$

$$c = \frac{a}{\beta_1} = \frac{1.55}{0.8} = 1.9375$$

$$\epsilon_s = \frac{(d-c)\epsilon_c}{c} = \frac{(21.6 - 1.9375)(0.003)}{1.9375} = 0.0305 > 0.005 \therefore \phi = 0.9$$

$$\phi M_n = \frac{(0.9)(1.32)(60)(21.6 - 1.55/2)}{12} = 124 \text{ 'K} > 101 \text{ 'K} \therefore \text{OK}$$

$$A_{s \text{ MIN}} = \begin{cases} \frac{3\sqrt{f_c'} b d}{f_y} = \frac{3\sqrt{5000}(12)(21.6)}{60000} = 0.916 \text{ in}^2 < A_s \text{ PROVIDED} \therefore \text{OK} \\ \frac{200 b d}{f_y} = \frac{200(12)(21.6)}{60000} = 0.864 \text{ in}^2 \end{cases}$$

SPACING: MEETS ACI 318-08 REQUIREMENTS

VERTICAL SHEAR: #4 STIRRUPS @ 12" o.c.

$$V_u \cdot \frac{w_u l_n}{2} = \frac{2.22(29' - 2')}{2} = 29.97 \text{ K}$$

$$\phi V_n = \phi (V_c + V_s) = 0.75 \left[2\sqrt{5000}(12'')(21.6) + (2)(0.2)(60000)(21.6/12) \right]$$

$$\phi V_n = 59.9 \text{ K} > 29.97 \text{ K} \therefore \text{OK}$$

BEAM DESIGN AT MIDSPAN:

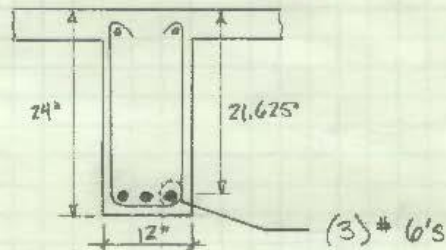

AT SUPPORTS: $M_u = -147 \text{ k}$

$$A_s = \frac{M_u}{4d} = \frac{147}{4(21.5)} = 1.71 \text{ in}^2$$

TRY (4) #6's $\rightarrow A_s = (4)(0.44) = 1.76$

$$\rho = \frac{1.76}{(12)(21)} = 0.00698 > 0.0025 \therefore \text{OK}$$

* TREAT AS RECTANGULAR BEAM

$$a = \frac{(1.76)(60)}{0.85(5)(12)} = 2.07 \text{ in}$$

$$c = \frac{2.07}{0.8} = 2.5875$$

$$d = 24 \text{ in} - 1.5 \text{ in} - \frac{1}{2} \text{ in} - \frac{0.75 \text{ in}}{2} = 21.625 \text{ in}$$

$$\epsilon_s = \frac{(21.6 - 2.5875)(0.005)}{2.5875} = 0.022 > 0.005 \therefore \phi = 0.9$$

$$\phi M_n = \frac{0.9(1.71)(60)(21.625 - 2.07/2)}{12} = 158 \text{ k} > 147 \text{ k} \therefore \text{OK}$$

$$A_{s \text{ MIN}} = 0.916 \text{ in}^2 < A_{s \text{ PROV}} \therefore \text{OK}$$

SHEAR \rightarrow OK BY INSPECTION

SPACING MEETS ACI 318-08 REQUIREMENTS

BEAM DESIGN AT SUPPORTS:

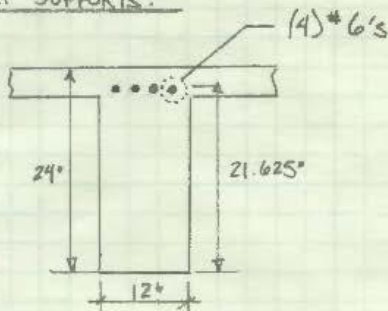

BEAM DEFLECTION CHECK:

$$\Delta_{LL} = \frac{5 (653.04 \text{ PLF}) (29')^4 (1728)}{384 (57000 + 5000) (12 (12) (24)^3)} = 0.187''$$

$$\Delta_{LL \text{ ALLOWABLE}} = \frac{29' \times 12''}{480} = 0.725'' > 0.187'' \therefore \text{OK}$$

$$\Delta_{TL} = \frac{5 (0.2375 + 0.742 + 0.653 / 1000) (29')^4 (1728)}{384 (57000 + 5000) (12 (12) (24)^3)} = 0.466''$$

$$\Delta_{TL \text{ ALLOWABLE}} = \frac{29' \times 12''}{240} = 1.45'' > 0.466'' \therefore \text{OK}$$

GIRDER DESIGN:

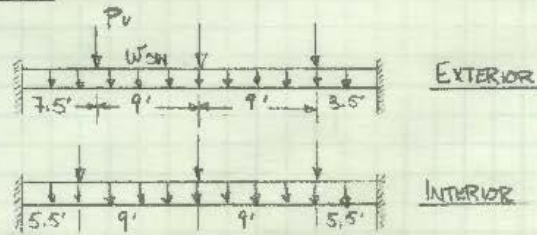

$$LL_r = 0.25 + \frac{15}{\sqrt{(29' \times 29') \times 2}} = 0.616$$

= 400 ft² ∴ OK

$$W_u = 1.2 (0.25) + 1.6 (0.616 \times 80) = 177.8 \text{ PLF} = 0.1778 \text{ KLF}$$

$$P_u = 0.1778 (9' \times 29') = 46.4 \text{ K} \text{ (CONSERVATIVE)}$$

$$W_{\text{SELF-WEIGHT}} = \frac{(29' - 5'') (24'') (150 \text{ lb/ft}^3)}{144} = 475 \text{ lb/ft} = 0.475 \text{ KLF}$$

EXTERIOR (RISA OUTPUT)

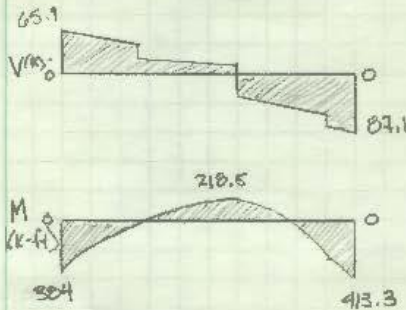

INTERIOR (RISA)

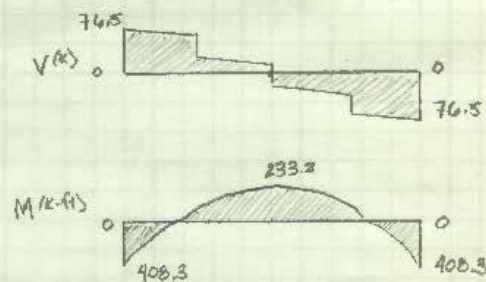

$$V_{MAX} = 87.1 \text{ k}$$

$$M^+_{MAX} = 233.2 \text{ k' (AT MIDSPAN)}$$

$$M^-_{MAX} = 413.3 \text{ k'}$$

AT MIDSPAN: $M_U = 233.2 \text{ k'}$

$$A_s = \frac{M_U}{4d} = \frac{233.2}{4(21'')} = 2.78 \text{ in}^2$$

$$T_R \#8's \rightarrow A_s = (4)(0.79) = 3.16 \text{ in}^2$$

$$d = 24'' - 1.5'' - \frac{1}{2}'' - \frac{1}{2}'' = 21.5''$$

$$\rho = \frac{3.16}{(24)(21.5)} = 0.00612 > 0.00125 \therefore \text{OK}$$

$$\text{DEVELOPMENT LENGTH: } \begin{array}{l} \text{TOP} \quad \frac{1}{4}(29' \times 12'') = 87'' \rightarrow \text{CONTROLS} \\ \text{MID} \quad 24 + 16(5'') = 104'' \\ \text{MIN} \quad 24 + 2(\frac{1}{2}(29' - 2'))(12'') = 348'' \end{array}$$

$$M_{U-TEN} = \frac{0.9 [0.85(5)(87'')(5'')(21.5 - 5\frac{1}{2})]}{12} = 2034 \text{ k' } > M_U$$

$$a = \frac{(3.16)(60)}{0.85(5)(24)} = 1.86''$$

$$c = \frac{1.86}{0.8} = 2.325$$

$$e_s = \frac{(21.5 - 2.325)(0.003)}{2.325} = 0.0247 > 0.005 \therefore \phi = 0.9$$

$$\phi M_n = \frac{0.9(2.78)(60)(21.5 - 1.86\frac{1}{2})}{12} = 257.3 \text{ k' } > 233.2 \text{ k' } \therefore \text{OK}$$

$$A_{s \text{ MIN}} = \frac{3\sqrt{5000}(24)(21.5)}{60000} = 1.82 \text{ in}^2 \Rightarrow \text{CONTROLS}$$

$$A_{s \text{ MAX}} = \frac{200(24)(21.5)}{60000} = 1.72 \text{ in}^2$$

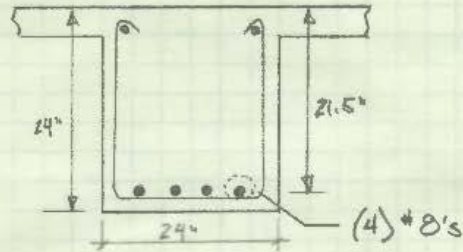
GIRDER DESIGN AT MIDSPAN:AT SUPPORTS:

$$M_u = 413.3 \text{ 'K}$$

$$A_s = \frac{M_u}{4d} = \frac{413.3}{4(21)} = 4.9 \text{ in}^2$$

$$\text{TRY } (5) \#9\text{'s} \Rightarrow A_s = (5)(1.0) = 5 \text{ in}^2$$

$$d = 24 - 1.5 - \frac{1}{2} - \frac{1.125}{2} = 21.436 \text{ ''}$$

$$p = \frac{5}{24(21.436)} = 0.0097 < 0.025 \therefore \text{OK}$$

*TREAT AS RECTANGULAR BEAM

$$a = \frac{5(60)}{0.85(5)(24)} = 2.94$$

$$c = \frac{2.94}{0.8} = 3.675$$

$$\epsilon_s = \frac{(21.436 - 3.675)(0.008)}{3.675} = 0.0145 > 0.005 \therefore \phi = 0.9$$

$$\phi M_n = \frac{0.9(5 \text{ in}^2)(60)(21.436 - 2.94/2)}{12} = 449.2 \text{ 'K} > 413.3 \text{ 'K} \therefore \text{OK}$$

$$A_{s \text{ MIN}} = 1.02 \text{ in}^2 < 5 \text{ in}^2 \therefore \text{OK}$$

SPACING MEETS ACI 318-08

GIRDER DESIGN AT SUPPORTS:

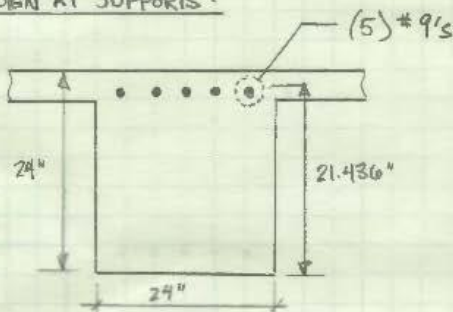

(5) #9's

24"

21.436"

24"

VERTICAL SHEAR: (#4 STIRRUPS @ 12")

$$V_u = 87.1 \text{ k}$$

$$\phi V_n = 0.75 \left[2 \sqrt{5000} (24) (21.436) + 2 (0.2) (60000) (21.436/2) \right]$$

$$\phi V_n = 86.7 \text{ k} < V_u \therefore \text{NG!}$$

TRY #4's @ 10" $\Rightarrow A_s = 0.24 \text{ in}^2$

$$\phi V_n = 0.75 \left[2 \sqrt{5000} (24) (21.436) + 2 (0.24) (60000) (21.436/2) \right]$$

$$\phi V_n = 93.2 \text{ k} > 87.1 \text{ k} \therefore \text{OK}$$

DEFLECTION: ASSUME SIMPLY SUPPORTED

$\Delta_{LL} \text{ ALLOWABLE} = 0.725"$

$\Delta_{TL} \text{ ALLOWABLE} = 1.45"$

$\Delta_{LL} = 0.2869" \text{ (OBTAINED FROM RAM CONCEPT)} \therefore \text{OK}$

$\Delta_{TL} = 0.702" \text{ (OBTAINED FROM RAM CONCEPT)} \therefore \text{OK}$

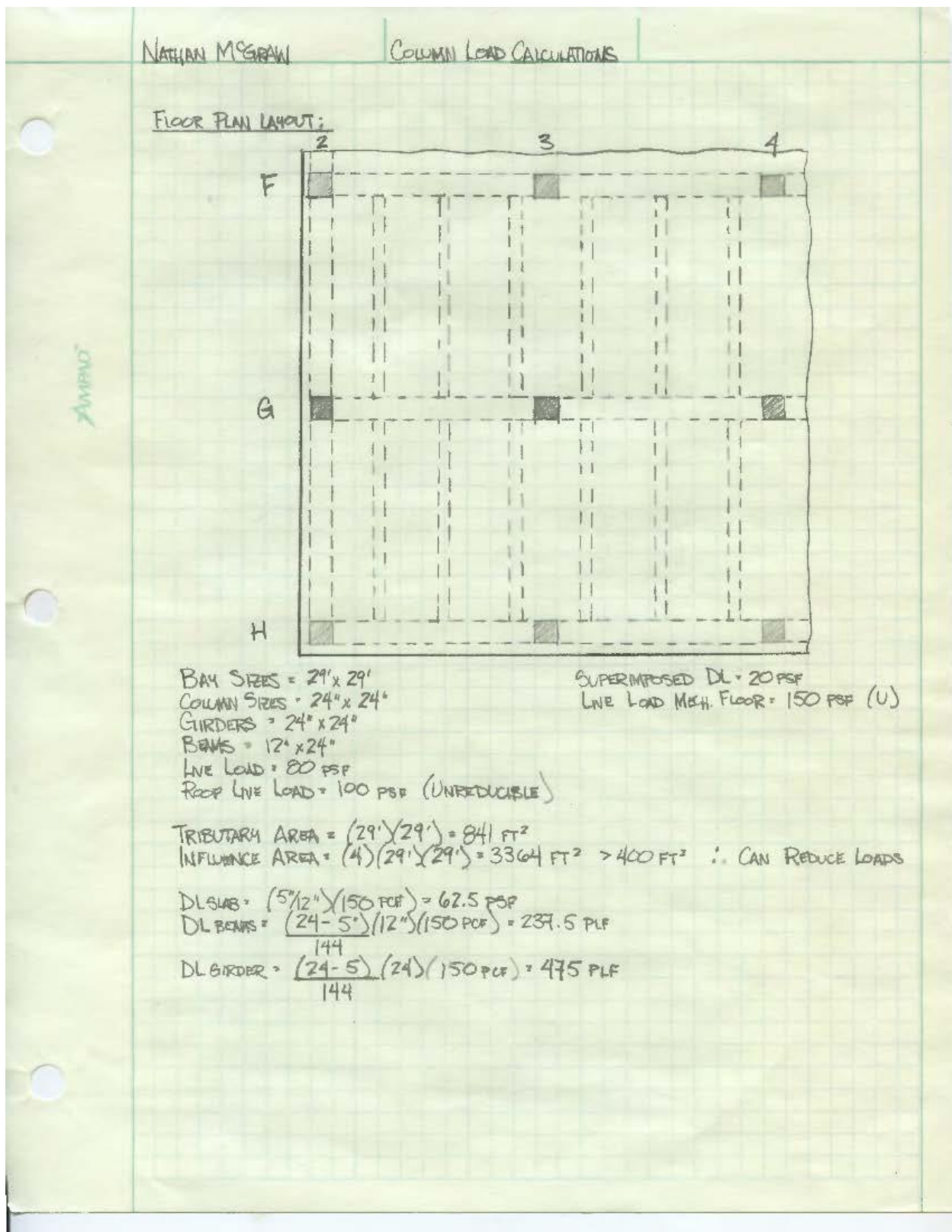

COLUMN LOADS: (G3)ROOF:

$$P_D = \frac{(841)(62.5 + 20)}{1000} + \frac{3(27')(237.5)}{1000} + \frac{(27')(475)}{1000} = 101.4 \text{ K}$$

$$P_L = \frac{(841)(100)}{1000} = 84.1 \text{ K}$$

11th FLOOR:

$$P_D = 101.4 \text{ K} + \left[\frac{(24')(24')(150)(15.333')}{144} \right] / 1000 = 110.6 \text{ K}$$

$$LL_r = 0.25 + \frac{15}{\sqrt{3364}} = 0.509 \Rightarrow P_L = \frac{(841)(80)(0.509)}{1000} = 34.2 \text{ K}$$

10th FLOOR:

$$P_D = 101.4 \text{ K} + \left[\frac{(24)(24)(150)(11.333')}{144} \right] / 1000 = 108.2 \text{ K}$$

$$LL_r = 0.25 + \frac{15}{\sqrt{2 \times 3364}} = 0.433 \Rightarrow P_L = \frac{(841)(80)(0.433)}{1000} = 29.1 \text{ K}$$

9th FLOOR:

$$P_D = 108.2 \text{ K}$$

$$LL_r = 0.25 + \frac{15}{\sqrt{3 \times 3364}} = 0.399 < 0.4 \Rightarrow P_L = \frac{(841)(80)(0.4)}{1000} = 26.9 \text{ K}$$

8th FLOOR:

$$P_D = 108.2 \text{ K}$$

$$P_L = 26.9 \text{ K}$$

7th FLOOR:

$$P_D = 108.2 \text{ K}$$

$$P_L = 26.9 \text{ K}$$

6th Floor:

$$P_D = 108.2 \text{ k}$$

$$P_L = 26.9 \text{ k}$$

5th Floor:

$$P_D = 101.4 \text{ k} + \left[\frac{(24 \times 24 \times 150 \times 14')}{144} \right] / 1000 = 109.8 \text{ k}$$

$$P_L = \frac{(841 \times 150)}{1000} = 126.2 \text{ k}$$

4th Floor:

$$P_D = 108.2 \text{ k}$$

$$P_L = 26.9 \text{ k}$$

3rd Floor:

$$P_D = 108.2 \text{ k}$$

$$P_L = 26.9 \text{ k}$$

2nd Floor:

$$P_D = 101.4 \text{ k} + \left[\frac{(28 \times 28 \times 150 \times 11.333')}{144} \right] = 110.7 \text{ k}$$

$$P_L = 26.9 \text{ k}$$

1st Floor:

$$P_D = 101.4 \text{ k} + \left[\frac{(28 \times 28 \times 150 \times 14')}{144} \right] / 1000 = 112.8 \text{ k}$$

$$P_L = 26.9 \text{ k}$$

GROUND FLOOR:

$$P_D = 101.4 \text{ k} + \left[\frac{(28 \times 28 \times 150 \times 10.667')}{144} \right] / 1000 = 110.1 \text{ k}$$

$$P_L = 84.1 \text{ k}$$

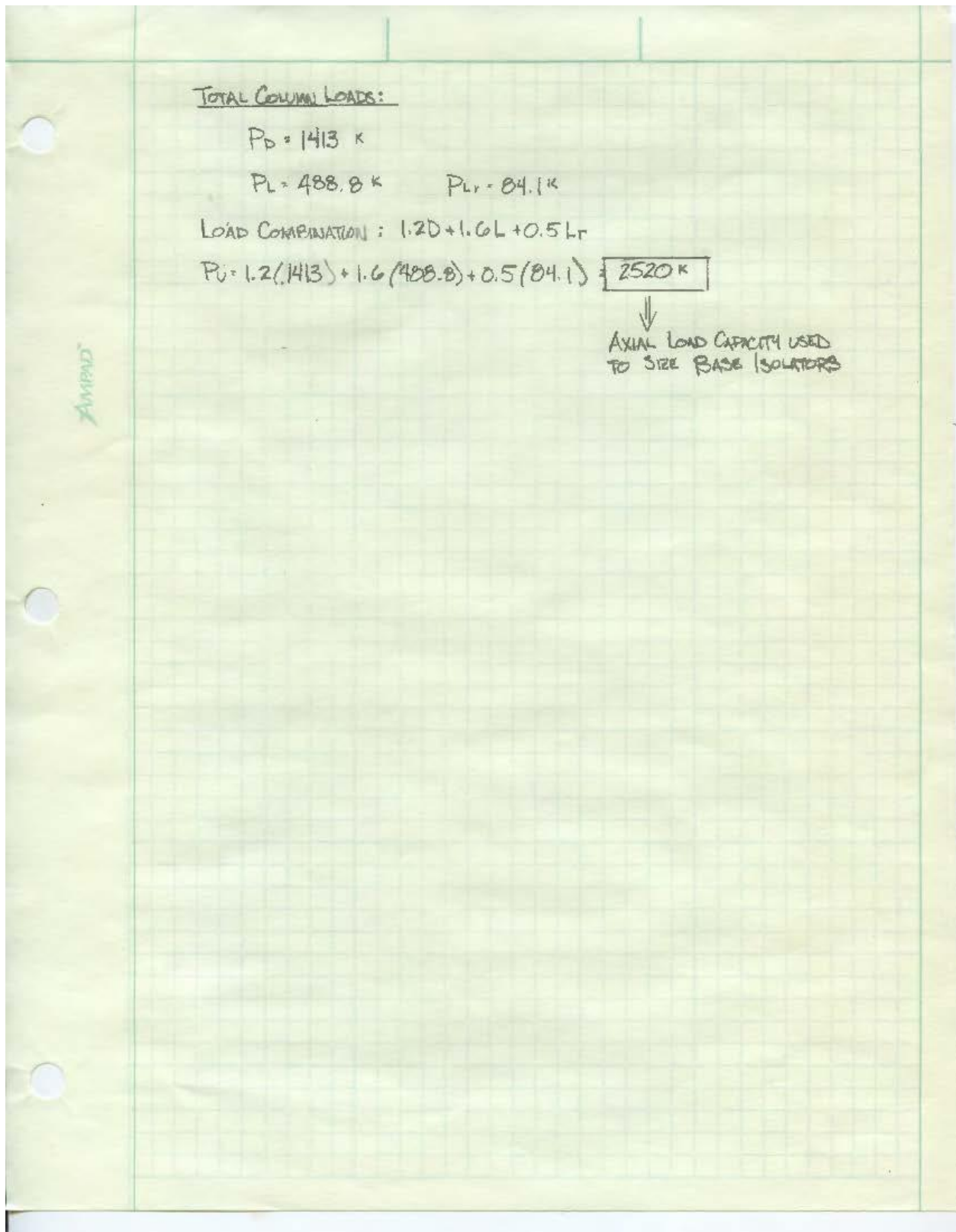

Appendix E: Fixed Base Iterations

Model With Moment Frames							Deflection Criteria Met?			
12" Shear Walls	Frame Size	Period	Maximum Drift X (in.)	Maximum Drift Y (in.)	S-3 Δ _a (1.0%)	S-1 Δ _a (0.5%)	S-3 _x	S-3 _y	S-1 _x	S-1 _y
	24x24	1.944	1.650	1.316	1.84	0.92	Yes	Yes	No	No
	24x28	1.786	1.292	1.199	1.84	0.92	Yes	Yes	No	No
	24x32	1.651	1.038	1.093	1.84	0.92	Yes	Yes	No	No
	24x36	1.537	0.859	1.001	1.84	0.92	Yes	Yes	Yes	No
Model With Moment Frames							Deflection Criteria Met?			
16" Shear Walls	Frame Size	Period	Maximum Drift X (in.)	Maximum Drift Y (in.)	S-3 Δ _a (1.0%)	S-1 Δ _a (0.5%)	S-3 _x	S-3 _y	S-1 _x	S-1 _y
	24x24	1.787	1.480	1.063	1.84	0.92	Yes	Yes	No	No
	24x28	1.660	1.201	0.986	1.84	0.92	Yes	Yes	No	No
	24x32	1.548	0.992	0.915	1.84	0.92	Yes	Yes	No	Yes
	24x36	1.450	0.836	0.851	1.84	0.92	Yes	Yes	Yes	Yes
Model With Moment Frames							Deflection Criteria Met?			
18" Shear Walls	Frame Size	Period	Maximum Drift X (in.)	Maximum Drift Y (in.)	S-3 Δ _a (1.0%)	S-1 Δ _a (0.5%)	S-3 _x	S-3 _y	S-1 _x	S-1 _y
	24x24	1.722	1.404	0.969	1.84	0.92	Yes	Yes	No	No
	24x28	1.607	1.155	0.905	1.84	0.92	Yes	Yes	No	Yes
	24x32	1.504	0.964	0.845	1.84	0.92	Yes	Yes	No	Yes
	24x36	1.413	0.820	0.791	1.84	0.92	Yes	Yes	Yes	Yes
Model With Moment Frames							Deflection Criteria Met?			
20" Shear Walls	Frame Size	Period	Maximum Drift X (in.)	Maximum Drift Y (in.)	S-3 Δ _a (1.0%)	S-1 Δ _a (0.5%)	S-3 _x	S-3 _y	S-1 _x	S-1 _y
	24x24	1.664	1.334	0.891	1.84	0.92	Yes	Yes	No	Yes
	24x28	1.559	1.111	0.837	1.84	0.92	Yes	Yes	No	Yes
	24x32	1.464	0.937	0.785	1.84	0.92	Yes	Yes	No	Yes
	24x36	1.379	0.803	0.738	1.84	0.92	Yes	Yes	Yes	Yes
Model With Moment Frames							Deflection Criteria Met?			
22" Shear Walls	Frame Size	Period	Maximum Drift X (in.)	Maximum Drift Y (in.)	S-3 Δ _a (1.0%)	S-1 Δ _a (0.5%)	S-3 _x	S-3 _y	S-1 _x	S-1 _y
	24x24	1.611	1.269	0.824	1.84	0.92	Yes	Yes	No	Yes
	24x28	1.515	1.068	0.778	1.84	0.92	Yes	Yes	No	Yes
	24x32	1.427	0.909	0.733	1.84	0.92	Yes	Yes	Yes	Yes
	24x36	1.348	0.784	0.692	1.84	0.92	Yes	Yes	Yes	Yes
Model With Moment Frames							Deflection Criteria Met?			
24" Shear Walls	Frame Size	Period	Maximum Drift X (in.)	Maximum Drift Y (in.)	S-3 Δ _a (1.0%)	S-1 Δ _a (0.5%)	S-3 _x	S-3 _y	S-1 _x	S-1 _y
	24x24	1.564	1.210	0.767	1.84	0.92	Yes	Yes	No	Yes
	24x28	1.475	1.028	0.727	1.84	0.92	Yes	Yes	No	Yes
	24x32	1.393	0.882	0.688	1.84	0.92	Yes	Yes	Yes	Yes
	24x36	1.319	0.766	0.652	1.84	0.92	Yes	Yes	Yes	Yes

Appendix F: Base Isolator Design Calculations

NATHAN MCGRAW SENIOR THESIS - FINAL SEISMIC ISOLATION

ANALYSIS PROCEDURE SELECTION: CHAPTER 17: SEISMICALLY ISOLATED STRUCTURES

- EQUIVALENT LATERAL FORCE PROCEDURE
 - $S_1 < 0.6g \Rightarrow S_1 = 0.325 \therefore \text{OK}$
 - SITE CLASS A, B, C OR D \Rightarrow SITE CLASS D $\therefore \text{OK}$
 - STRUCTURE ABOVE ISOLATION SURFACE ≤ 4 STORIES OR 65' $\Rightarrow 145' \therefore \text{NGX}$

\therefore MUST USE DYNAMIC PROCEDURES

HOWEVER, NEED EQUIVALENT FORCE PROCEDURE VALUES:

EQUIVALENT LATERAL FORCE PROCEDURE:

DESIGN DISPLACEMENT:

$$D_D = \frac{g S_D T_D}{4\pi^2 B_D}$$

EFFECTIVE PERIOD OF DESIGN DISPLACEMENT:

$$T_D = 2\pi \sqrt{\frac{W}{K_{D, \text{MIN}} g}}$$

MAXIMUM DISPLACEMENT:

$$D_M = \frac{g S_M T_M}{4\pi^2 B_M}$$

EFFECTIVE PERIOD AT MAXIMUM DISPLACEMENT:

$$T_M = 2\pi \sqrt{\frac{W}{K_{M, \text{MIN}} g}}$$

TOTAL DISPLACEMENT:

$$D_{TD} = D_D \left[1 + \gamma \frac{12e}{b^2 + d^2} \right]$$

$$D_{TM} = D_M \left[1 + \gamma \frac{12e}{b^2 + d^2} \right]$$

MINIMUM LATERAL FORCES :

$$V_b = K_{Dmax} D_D$$

STRUCTURE ELEMENTS ABOVE THE ISOLATION SYSTEM :

$$V_s = \frac{K_{Dmax} D_D}{R_I}$$

$$R_I = \frac{3}{8} R \quad 1.0 \leq R_I \leq 2.0$$

V_s SHALL NOT BE LESS THAN :

1. FIXED-BASE STRUCTURE USING T_D
2. WIND BASE SHEAR
3. FORCE REQUIRED TO ACTIVATE THE ISOLATION SYSTEM

VERTICAL DISTRIBUTION OF FORCE :

$$F_x = \frac{V_s w_x h_x}{\sum_{i=1}^n w_i h_i}$$

DRIFT LIMITS :

$$\Delta_{\text{maximum}} = 0.015 h_{sx} \quad (\text{S-1 PERFORMANCE : } 0.005 h_{sx})$$

DYNAMIC PROCEDURE :

RESPONSE HISTORY PROCEDURE : §17.6.3.4 AND §17.3.2

- §17.6.3.4 {
- NOT FEWER THAN 3 APPROPRIATE GROUND MOTIONS
 - MAXIMUM DISPLACEMENT = VECTORIAL SUM OF TWO ORTHOGONAL DISPLACEMENTS
 - IF FEWER THAN 7 GROUND MOTIONS USED, THE MAXIMUM VALUE OF THE RESPONSE PARAMETER OF INTEREST SHALL BE USED FOR DESIGN
- §17.3.2 {
- APPROPRIATE MAGNITUDES, FAULT DISTANCE AND SOURCE MECHANISM THAT ARE CONSISTENT WITH THOSE THAT CONTROL THE MAXIMUM CONSIDERED EARTHQUAKE
 - MOTIONS SHALL BE SCALED SUCH THAT FOR EACH PERIOD BETWEEN 0.5T_D AND 1.25T_D, THE AVERAGE SRSS SPECTRA DOES NOT FALL BELOW 1.3 TIMES THE DESIGN RESPONSE SPECTRUM

MINIMUM LATERAL DISPLACEMENTS AND FORCES: § 17.6.4

- ISOLATION SYSTEM AND STRUCTURAL ELEMENTS BELOW ISOLATION SYSTEM:

$$\text{DESIGN LATERAL FORCE} \geq 0.9 V_b$$

$$\text{DESIGN DISPLACEMENT} \geq 0.9 D_{TP}$$

$$\text{MAXIMUM DISPLACEMENT} \geq 0.8 D_{TM}$$

$$D'_D = \frac{D_D}{\sqrt{1 + \left(\frac{T}{T_D}\right)^2}}$$

$$D'_{TM} = \frac{D_{TM}}{\sqrt{1 + \left(\frac{T}{T_M}\right)^2}}$$

- STRUCTURAL ELEMENTS ABOVE THE ISOLATION SYSTEM

$$\begin{aligned} \text{DESIGN LATERAL FORCE} &\geq 0.8 V_s \text{ IF REGULAR IN CONFIGURATION} \\ &\geq 0.6 V_s \text{ IF RESPONSE HISTORY PROCEDURE USED} \end{aligned}$$

$$\begin{aligned} \text{DESIGN LATERAL FORCE} &\geq V_s \text{ IF IRREGULAR IN CONFIGURATION} \\ &\geq 0.8 V_s \text{ IF RESPONSE HISTORY PROCEDURE USED} \end{aligned}$$

DRIFT LIMITS: § 17.6.4.4

1. IF RESPONSE SPECTRUM USED $\Rightarrow 0.015 h_{sx}$
2. IF RESPONSE HISTORY ANALYSIS $\Rightarrow 0.020 h_{sx}$
3. DRIFTS SHALL BE CALCULATED WITH THE C_D FACTOR OF THE ISOLATED STRUCTURE EQUAL TO R_B ($\approx 3/8 R$)

$S_s =$	0.900
$S_1 =$	0.325
$S_{M1} =$	0.49
$S_{D1} =$	0.325
$R =$	6.5
$W =$	37,184 kips
$b =$	87 ft
$d =$	190.75 ft
$e =$	23.6 ft (with 5% accidental torsion)
$g =$	386.4 in./sec ²
$T_{str.} =$	1.78
$T_D =$	8.9 sec.
$T_M =$	10.2 sec.
Damping =	15%
Variation =	10% (Variation in stiffness from the mean stiffness values of the isolators is considered acceptable)

Effective Period of Design Displacement:

$$T_D = 2\pi \sqrt{\frac{W}{k_{D,MIN}g}}$$

$$k_{D,MIN} = 48.0 \text{ k/in.}$$

Effective Period at Maximum Displacement:

$$T_M = 2\pi \sqrt{\frac{W}{k_{M,MIN}g}}$$

$$k_{M,MIN} = 36.3 \text{ k/in.}$$

Design Effective Damping in the System:

$$\beta_D = \frac{1}{2\pi} \left[\frac{\text{total area of hysteresis loop}}{K_{D,MAX} D^2} \right]$$

$$k_{D,MAX} = 58.6 \text{ k/in.}$$

Maximum Effective Damping in the System:

$$\beta_M = \frac{1}{2\pi} \left[\frac{\text{total area of hysteresis loop}}{K_{M,MAX} D^2} \right]$$

$$k_{D,MAX} = 44.3 \text{ k/in.}$$

$$B_D = 1.35 \text{ (Table 17.5-1 Damping Coefficient)}$$

$$B_M = 1.35 \text{ *Assumed same level of damping assigned to both directions}$$

Design Displacement:

$$D_D = \frac{gS_{D1}T_D}{4\pi^2 B_D} \quad 20.97 \text{ in.}$$

Maximum Displacement:

$$D_M = \frac{gS_{M1}T_M}{4\pi^2 B_M} \quad 36.36 \text{ in.}$$

Total Displacement:

$$D_{TD} = D_D \left[1 + y \frac{12e}{b^2 + d^2} \right] \quad 33.9 \text{ in.}$$

$$D_{TM} = D_M \left[1 + y \frac{12e}{b^2 + d^2} \right] \quad 58.7 \text{ in.}$$

Minimum Lateral Forces: (Isolation System and Structural Elements below the Isolation System)

$$V_b = k_{D,MAX} D_D \quad 1229 \text{ kips}$$

Structure Elements Above the Isolation System:

$$V_s = \frac{k_{D,MAX} D_D}{R_i} \quad 614.7 \text{ kips}$$

$$R_i = (3/8)R = 2.438 \quad 1.0 \leq R_i \leq 2.0 \quad \therefore 2.0$$

Limits on V_s :

- 1.) $V_s >$ The lateral system force required from Section 12.8 for a fixed base structure of the same effective seismic weight and a period equal to the isolated period (T_D)
- 2.) The base shear corresponding to the factored design wind load
- 3.) The lateral seismic force required to fully activate the isolation system multiplied by 1.5

1.)

Sacramento CA

Latitude: 38.55

Longitude -121.74

Site Class: D

 $S_s = 0.900$ *USGS Web Application (Confirmed with Figure 22-1 of ASCE 7-05) $S_1 = 0.325$ *USGS Web Application (Confirmed with Figure 22-2 of ASCE 7-05) $T_L = 8$ sec. (Confirmed with Figure 22-15 of ASCE 7-05)

Occupancy Category IV (Table 1.1)

Importance Factor = 1.5 (Table 11.5.1)

Site Coefficient, $F_a = 1.0$ (Table 11.4-1)Site Coefficient, $F_v = 1.5$ (Table 11.4-2) $S_{MS} = 0.90$ $F_a \cdot S_s$ (11.4-1) $S_{M1} = 0.49$ $F_v \cdot S_1$ (11.4-2) $S_{DS} = 0.600$ $(2/3)S_{MS}$ (11.4-3) $S_{D1} = 0.325$ $(2/3)S_{M1}$ (11.4-4)

Short Period SDC = D (Table 11.6-1)

1.0-s Period SDC = D (Table 11.6-2)

Permitted Analytical Procedure Modal Response Spectrum Analysis (Table 12.6-1)
Seismic Response History Procedure (Table 12.6-1)

Response Modification Coefficient 6.5 (Table 12.2-1)

Amplification Factor 5.0 (Table 12.2-1)

Approximate Fundamental Period:

$$T_a = C_t h_n^x$$

 $C_t = 0.02$ (Table 12.8-2) $x = 0.75$ (Table 12.8-2) $h_n = 145$ ft. $T_a = 0.8357$ sec. $C_u = 1.4$ (Table 12.8-1) $C_u T_a = 1.17$ sec. (Upper Limit on Calculated Period) $T_D = 8.90$ sec.

Seismic Response Coefficient:

$$C_s = \begin{cases} \frac{S_{DS}}{(R/I)} = \frac{0.6}{(4.5/1.5)} = 0.138 & \text{(Eqn. 12.8-2)} \\ \frac{S_{D1}}{T(R/I)} = \frac{0.325}{.17(4.5/1)} = 0.008 \geq 0.01 & \text{(Eqn. 12.8-3)} \\ \min \left\{ \frac{S_{D1}T_L}{T^2(R/I)} = \frac{(0.325)(8)}{.17^2(4.5/1)} = 0.008 \right. & \text{(Eqn. 12.8-4)} \end{cases}$$

For $S_1 \geq 0.6g$:
Apply: **No**

$$C_s \geq \frac{0.5S_{DS}}{(R/I)} = \frac{1.333}{(4.5/1.5)} = 0.069 \quad \text{(Eqn. 12.8-6)}$$

$C_s = 0.008$

Base Shear $V = C_s W$

$W = 37,184$ kips

$V = C_s W = 282$ kips < $V_s = 615$ kips **OK**

2.) $V_{wind} = 416$ kips < $V_s = 615$ kips **OK**

3.) Assume the lateral seismic force required to fully activate the isolation system is met **OK**

Proposed Structure: University of California – Davis (Sacramento) CA – Base Isolation Model
 (only worst EQ iteration for preliminary size is shown for convenience)

El Centro Array #6 - Maximum Displacements/Drifts							
	Level	δ_{XE}	Δ_x	S-3 Δ_a (1.0%)	S-1 Δ_a (0.5%)	S-3 Met	S-1 Met
T = 2.6 sec., K_{vert} = 16000 k/in., K_{linear} = 37 k/in., $K_{nonlinear}$ = 370 k/in., Yield Strength = 75 k, Post Yield Stiffness Ratio = 0.2	Penthouse/Roof	15.4	1.0	1.88	0.94	Yes	No
	11th	14.5	0.7	1.36	0.68	Yes	No
	10th	13.7	0.8	1.36	0.68	Yes	No
	9th	13.0	0.8	1.36	0.68	Yes	No
	8th	12.1	0.9	1.36	0.68	Yes	No
	7th	11.2	0.9	1.36	0.68	Yes	No
	6th	10.3	1.2	1.68	0.84	Yes	No
	5th	9.1	1.0	1.36	0.68	Yes	No
	4th	8.1	1.0	1.36	0.68	Yes	No
	3rd	7.1	0.6	1.36	0.68	Yes	Yes
	2nd	6.5	1.5	1.68	0.84	Yes	No
	1st	5.0	2.4	1.28	0.64	No	No
	Ground	2.6	N/A	N/A	N/A	N/A	N/A
El Centro Array #6 - Maximum Displacements/Drifts							
	Level	δ_{XE}	Δ_x	S-3 Δ_a (1.0%)	S-1 Δ_a (0.5%)	S-3 Met	S-1 Met
T = 3.1 sec., K_{vert} = 16000 k/in., K_{linear} = 15.5 k/in., $K_{nonlinear}$ = 155 k/in., Yield Strength = 75 k, Post Yield Stiffness Ratio = 0.2	Penthouse/Roof	13.1	0.7	1.88	0.94	Yes	Yes
	11th	12.5	0.5	1.36	0.68	Yes	Yes
	10th	12.0	0.5	1.36	0.68	Yes	Yes
	9th	11.4	0.6	1.36	0.68	Yes	Yes
	8th	10.9	0.6	1.36	0.68	Yes	Yes
	7th	10.3	0.6	1.36	0.68	Yes	Yes
	6th	9.6	0.8	1.68	0.84	Yes	Yes
	5th	8.8	0.7	1.36	0.68	Yes	No
	4th	8.1	0.7	1.36	0.68	Yes	Yes
	3rd	7.4	0.4	1.36	0.68	Yes	Yes
	2nd	7.0	1.1	1.68	0.84	Yes	No
	1st	6.0	1.8	1.28	0.64	No	No
	Ground	4.2	N/A	N/A	N/A	N/A	N/A

El Centro Array #6 - Maximum Displacements/Drifts							
	Level	δ_{XE}	Δ_X	S-3 Δ_a (1.0%)	S-1 Δ_a (0.5%)	S-3 Met	S-1 Met
T = 4.51 sec., $K_{vert} = 16000$ k/in., $K_{linear} = 6$ k/in., $K_{nonlinear} = 60$ k/in., Yield Strength = 75 k, Post Yield Stiffness Ratio = 0.2	Penthouse/Roof	13.6	0.4	1.88	0.94	Yes	Yes
	11th	13.1	0.3	1.36	0.68	Yes	Yes
	10th	12.8	0.4	1.36	0.68	Yes	Yes
	9th	12.4	0.4	1.36	0.68	Yes	Yes
	8th	12.1	0.4	1.36	0.68	Yes	Yes
	7th	11.7	0.4	1.36	0.68	Yes	Yes
	6th	11.2	0.6	1.68	0.84	Yes	Yes
	5th	10.7	0.5	1.36	0.68	Yes	Yes
	4th	10.2	0.4	1.36	0.68	Yes	Yes
	3rd	9.8	0.2	1.36	0.68	Yes	Yes
	2nd	9.6	0.8	1.68	0.84	Yes	Yes
	1st	8.8	1.4	1.28	0.64	No	No
	Ground	7.4	N/A	N/A	N/A	N/A	N/A
El Centro Array #6 - Maximum Displacements/Drifts							
	Level	δ_{XE}	Δ_X	S-3 Δ_a (1.0%)	S-1 Δ_a (0.5%)	S-3 Met	S-1 Met
T = 2.6 sec., $K_{vert} = 16000$ k/in., $K_{linear} = 37$ k/in., $K_{nonlinear} = 370$ k/in., Yield Strength = 150 k, Post Yield Stiffness Ratio = 0.2	Penthouse/Roof	11.0	0.7	1.88	0.94	Yes	Yes
	11th	10.4	0.5	1.36	0.68	Yes	Yes
	10th	9.8	0.6	1.36	0.68	Yes	Yes
	9th	9.3	0.6	1.36	0.68	Yes	Yes
	8th	8.7	0.6	1.36	0.68	Yes	Yes
	7th	8.0	0.7	1.36	0.68	Yes	Yes
	6th	7.4	0.9	1.68	0.84	Yes	No
	5th	6.5	0.7	1.36	0.68	Yes	No
	4th	5.8	0.7	1.36	0.68	Yes	No
	3rd	5.1	0.5	1.36	0.68	Yes	Yes
	2nd	4.6	1.0	1.68	0.84	Yes	No
	1st	3.5	1.7	1.28	0.64	No	No
	Ground	1.9	N/A	N/A	N/A	N/A	N/A

El Centro Array #6 - Maximum Displacements/Drifts							
	Level	δ_{XE}	Δ_X	S-3 Δ_a (1.0%)	S-1 Δ_a (0.5%)	S-3 Met	S-1 Met
T = 3.1 sec., $K_{vert} = 16000$ k/in., $K_{linear} = 15.5$ k/in., $K_{nonlinear} = 155$ k/in., Yield Strength = 150 k, Post Yield Stiffness Ratio = 0.2	Penthouse/Roof	8.1	0.4	1.88	0.94	Yes	Yes
	11th	7.7	0.3	1.36	0.68	Yes	Yes
	10th	7.4	0.3	1.36	0.68	Yes	Yes
	9th	7.1	0.4	1.36	0.68	Yes	Yes
	8th	6.7	0.4	1.36	0.68	Yes	Yes
	7th	6.3	0.4	1.36	0.68	Yes	Yes
	6th	5.9	0.5	1.68	0.84	Yes	Yes
	5th	5.4	0.4	1.36	0.68	Yes	Yes
	4th	4.9	0.4	1.36	0.68	Yes	Yes
	3rd	4.5	0.3	1.36	0.68	Yes	Yes
	2nd	4.2	0.7	1.68	0.84	Yes	Yes
	1st	3.6	1.1	1.28	0.64	Yes	No
	Ground	2.5	N/A	N/A	N/A	N/A	N/A
El Centro Array #6 - Maximum Displacements/Drifts							
	Level	δ_{XE}	Δ_X	S-3 Δ_a (1.0%)	S-1 Δ_a (0.5%)	S-3 Met	S-1 Met
T = 4.51 sec., $K_{vert} = 16000$ k/in., $K_{linear} = 6$ k/in., $K_{nonlinear} = 60$ k/in., Yield Strength = 150 k, Post Yield Stiffness Ratio = 0.2	Penthouse/Roof	8.7	0.3	1.88	0.94	Yes	Yes
	11th	8.4	0.2	1.36	0.68	Yes	Yes
	10th	8.2	0.2	1.36	0.68	Yes	Yes
	9th	7.9	0.3	1.36	0.68	Yes	Yes
	8th	7.7	0.3	1.36	0.68	Yes	Yes
	7th	7.4	0.3	1.36	0.68	Yes	Yes
	6th	7.1	0.4	1.68	0.84	Yes	Yes
	5th	6.7	0.3	1.36	0.68	Yes	Yes
	4th	6.4	0.3	1.36	0.68	Yes	Yes
	3rd	6.1	0.1	1.36	0.68	Yes	Yes
	2nd	6.0	0.5	1.68	0.84	Yes	Yes
	1st	5.5	0.9	1.28	0.64	Yes	No
	Ground	4.6	N/A	N/A	N/A	N/A	N/A

El Centro Array #6 - Maximum Displacements/Drifts							
	Level	δ_{XE}	Δ_X	S-3 Δ_a (1.0%)	S-1 Δ_a (0.5%)	S-3 Met	S-1 Met
T = 2.6 sec., K_{vert} = 16000 k/in., K_{linear} = 37 k/in., $K_{nonlinear}$ = 370 k/in., Yield Strength = 37.5 k, Post Yield Stiffness Ratio = 0.2	Penthouse/Roof	18.6	1.1	1.88	0.94	Yes	No
	11th	17.4	0.9	1.36	0.68	Yes	No
	10th	16.5	0.9	1.36	0.68	Yes	No
	9th	15.6	1.0	1.36	0.68	Yes	No
	8th	14.6	1.1	1.36	0.68	Yes	No
	7th	13.5	1.1	1.36	0.68	Yes	No
	6th	12.4	1.5	1.68	0.84	Yes	No
	5th	11.0	1.2	1.36	0.68	Yes	No
	4th	9.8	1.2	1.36	0.68	Yes	No
	3rd	8.6	0.8	1.36	0.68	Yes	No
	2nd	7.9	1.7	1.68	0.84	No	No
	1st	6.1	2.9	1.28	0.64	No	No
	Ground	3.2	N/A	N/A	N/A	N/A	N/A
El Centro Array #6 - Maximum Displacements/Drifts							
	Level	δ_{XE}	Δ_X	S-3 Δ_a (1.0%)	S-1 Δ_a (0.5%)	S-3 Met	S-1 Met
T = 3.1 sec., K_{vert} = 16000 k/in., K_{linear} = 15.5 k/in., $K_{nonlinear}$ = 155 k/in., Yield Strength = 37.5 k, Post Yield Stiffness Ratio = 0.2	Penthouse/Roof	18.0	0.9	1.88	0.94	Yes	Yes
	11th	17.1	0.7	1.36	0.68	Yes	Yes
	10th	16.4	0.7	1.36	0.68	Yes	No
	9th	15.7	0.8	1.36	0.68	Yes	No
	8th	15.0	0.8	1.36	0.68	Yes	No
	7th	14.2	0.9	1.36	0.68	Yes	No
	6th	13.3	1.1	1.68	0.84	Yes	No
	5th	12.2	0.9	1.36	0.68	Yes	No
	4th	11.3	0.9	1.36	0.68	Yes	No
	3rd	10.4	0.5	1.36	0.68	Yes	Yes
	2nd	9.9	1.4	1.68	0.84	Yes	No
	1st	8.4	2.4	1.28	0.64	No	No
	Ground	6.0	N/A	N/A	N/A	N/A	N/A

El Centro Array #6 - Maximum Displacements/Drifts							
	Level	δ_{XE}	Δ_X	S-3 Δ_a (1.0%)	S-1 Δ_a (0.5%)	S-3 Met	S-1 Met
T = 4.51 sec., $K_{vert} = 16000$ k/in., $K_{linear} = 6$ k/in., $K_{nonlinear} = 60$ k/in., Yield Strength = 37.5 k, Post Yield Stiffness Ratio = 0.2	Penthouse/Roof	25.5	0.7	1.88	0.94	Yes	Yes
	11th	24.8	0.6	1.36	0.68	Yes	Yes
	10th	24.2	0.6	1.36	0.68	Yes	Yes
	9th	23.6	0.6	1.36	0.68	Yes	Yes
	8th	22.9	0.68	1.36	0.68	Yes	Yes
	7th	22.3	0.67	1.36	0.68	Yes	Yes
	6th	21.6	0.68	1.68	0.84	Yes	Yes
	5th	20.9	0.68	1.36	0.68	Yes	Yes
	4th	20.2	0.67	1.36	0.68	Yes	Yes
	3rd	19.6	0.63	1.36	0.68	Yes	Yes
	2nd	18.9	0.8	1.68	0.84	Yes	Yes
	1st	18.1	0.6	1.28	0.64	Yes	Yes
	Ground	17.5	N/A	N/A	N/A	N/A	N/A

Base Isolator Dimensions/Connection:

DEVICE SIZE				MOUNTING PLATE DIMENSIONS					
Isolator Diameter, D_1 (in)	Isolator Height, H (in)	Number of Rubber Layers, N	Lead Diameter D_L (in)	L (in)	t (in)	Hole Qty.	Hole ϕ (in)	A (in)	B (in)
12.0	5-11	4-14	0-4	14	1	4	1 1/16	2	-
14.0	6-12	5-16	0-4	16	1	4	1 1/16	2	-
16.0	7-13	6-20	0-5	18	1	4	1 1/16	2	-
18.0	7-14	6-20	0-5	20	1	4	1 1/16	2	-
20.5	8-15	8-24	0-7	22.5	1	8	1 1/16	2	2
22.5	8-15	8-24	0-7	24.5	1	8	1 1/16	2	2
25.5	8-15	8-24	0-8	27.5	1.25	8	1 1/16	2	2
27.5	8-17	8-30	0-8	29.5	1.25	8	1 5/16	2.5	3
29.5	9-18	8-30	0-9	31.5	1.25	8	1 5/16	2.5	3
31.5	9-20	8-33	0-9	33.5	1.25	8	1 5/16	2.5	3
33.5	9-21	8-35	0-10	35.5	1.5	12	1 5/16	2.5	3.75
35.5	10-22	9-37	0-10	37.5	1.5	12	1 5/16	2.5	3.75
37.5	10-23	10-40	0-11	39.5	1.5	12	1 5/16	2.5	3.75
39.5	11-25	11-40	0-11	41.5	1.5	12	1 9/16	3	4.5
41.5	12-26	12-45	0-12	43.5	1.75	12	1 9/16	3	4.5
45.5	13-30	14-45	0-13	47.5	1.75	12	1 9/16	3	4.5
49.5	14-30	16-45	0-14	52.5	1.75	16	1 9/16	3	4.5
53.5	16-30	18-45	0-15	56.5	2	16	1 9/16	3	4.5
57.1	17-30	20-45	0-16	60	2	20	1 9/16	3	4.5
61.0	18-30	22-45	0-16	64	2	20	1 9/16	3	4.5

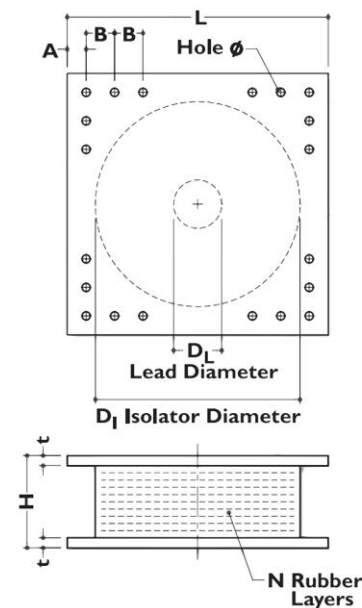

Proposed Structure: University of California – Davis (Sacramento) CA – Base Isolation Model
 Column Design (Only one column shown)

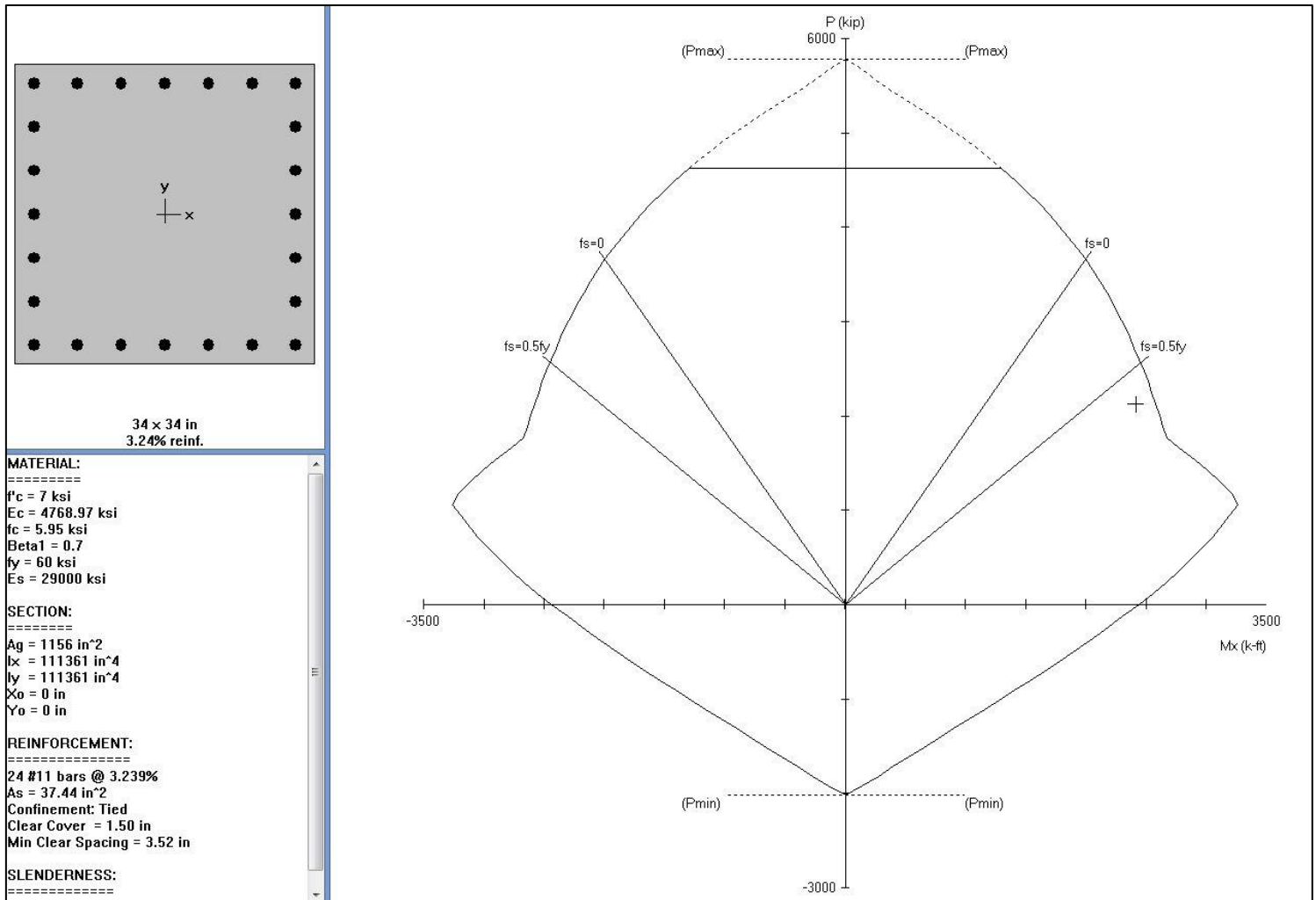

Appendix G: Earthquake Scaling for Time History Analysis

X-Direction				
Earthquake Name/Station	Magnitude	PGA (g)	PGV (cm/s)	Scale Factor
Imperial Valley-06/El Centro Array #6	6.53	0.4417	111.8402	0.6488
Imperial Valley-06/El Centro Array #7	6.53	0.4624	108.7935	0.7061
Northridge-01/Rinaldi Receiving Station	6.69	0.8698	167.051	0.5216
Northridge-01/Sylmar - Olive View	6.69	0.7326	122.7694	0.5929
Loma Prieta/Saratoga - Aloha	6.93	0.3761	55.5459	0.8603
Cape Mendocino/Petrolia	7.01	0.6296	81.8727	0.6844
Kocaeli, Turkey/Izmit	7.51	0.2198	29.7636	1.3784
Y-Direction				
Earthquake Name/Station	Magnitude	PGA (g)	PGV (cm/s)	Scale Factor
Imperial Valley-06/Bonds Corner	6.53	0.7639	44.2457	0.7251
Imperial Valley-06/Chihuahua	6.53	0.2843	30.4074	1.3686
Northridge-01/LA - Sepulveda VA	6.69	0.7312	69.979	0.6127
Northridge-01/Northridge - Saticoy	6.69	0.4133	53.1713	0.7784
Loma Prieta/Corralitos	6.93	0.5136	45.4288	0.9611
Cape Mendocino/Cape Mendocino	7.01	1.4314	118.3109	0.5812
Kocaeli, Turkey/Yarimca	7.51	0.3119	72.9142	0.7245

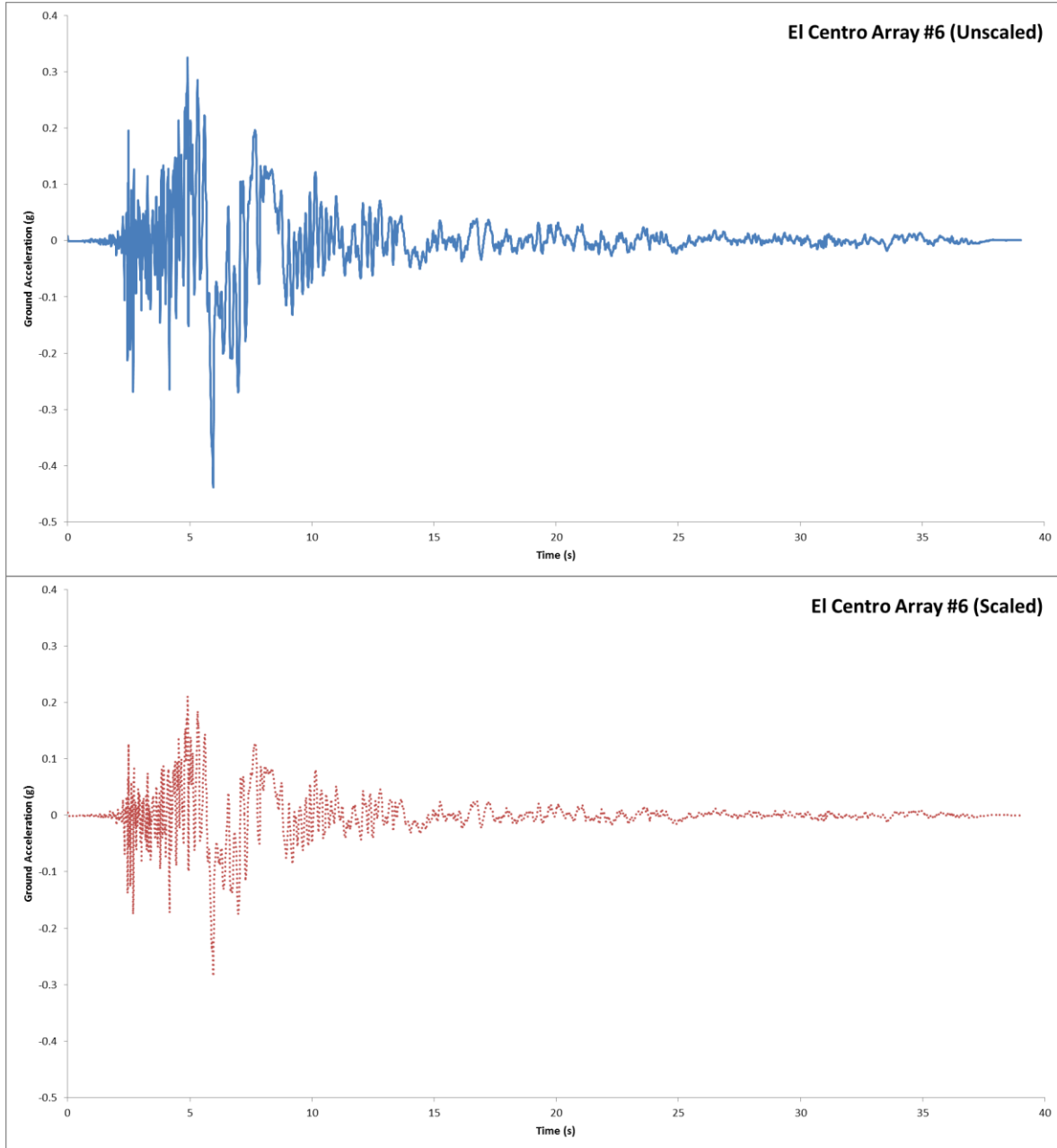

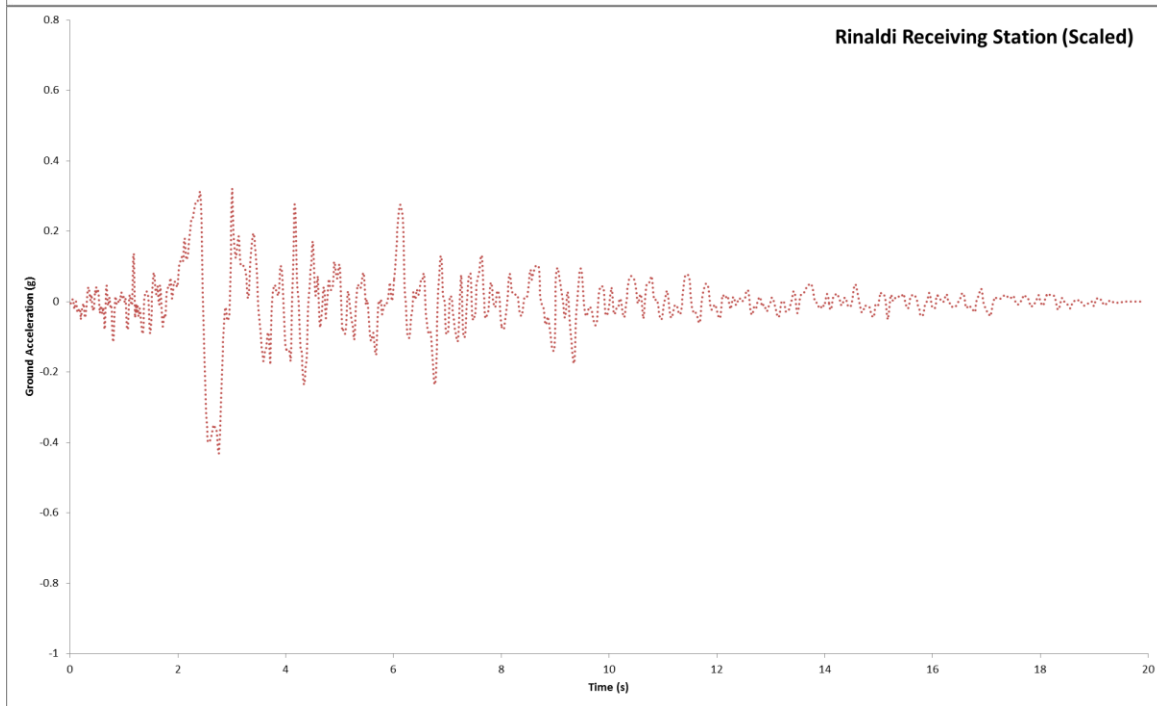
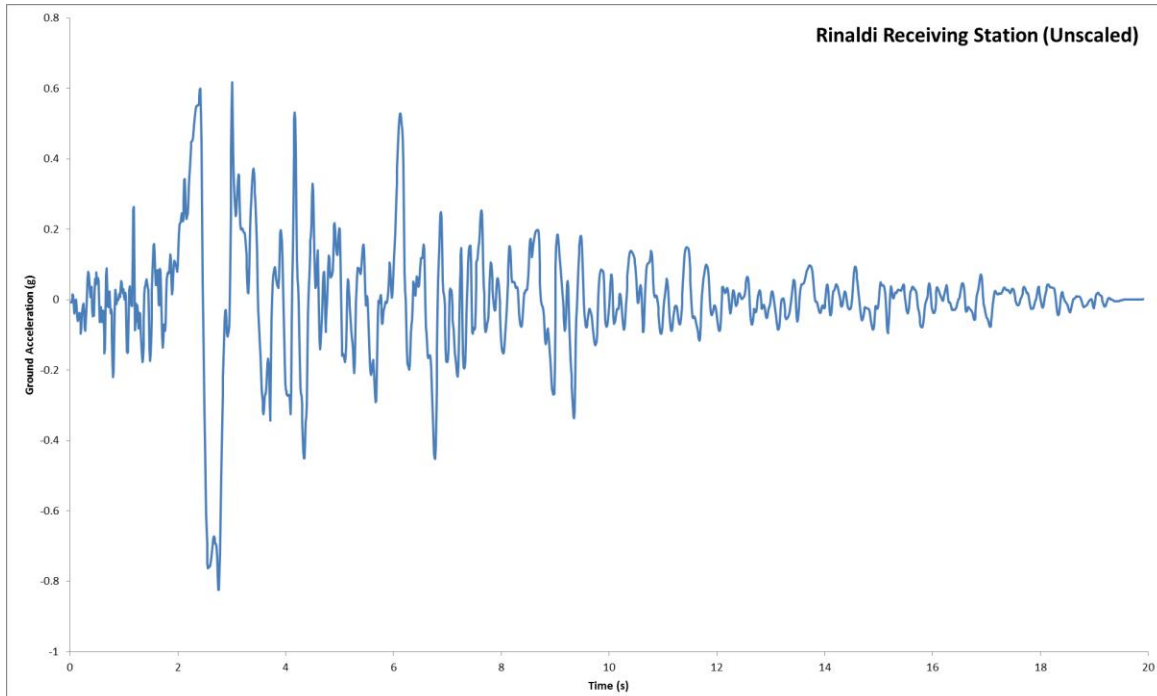

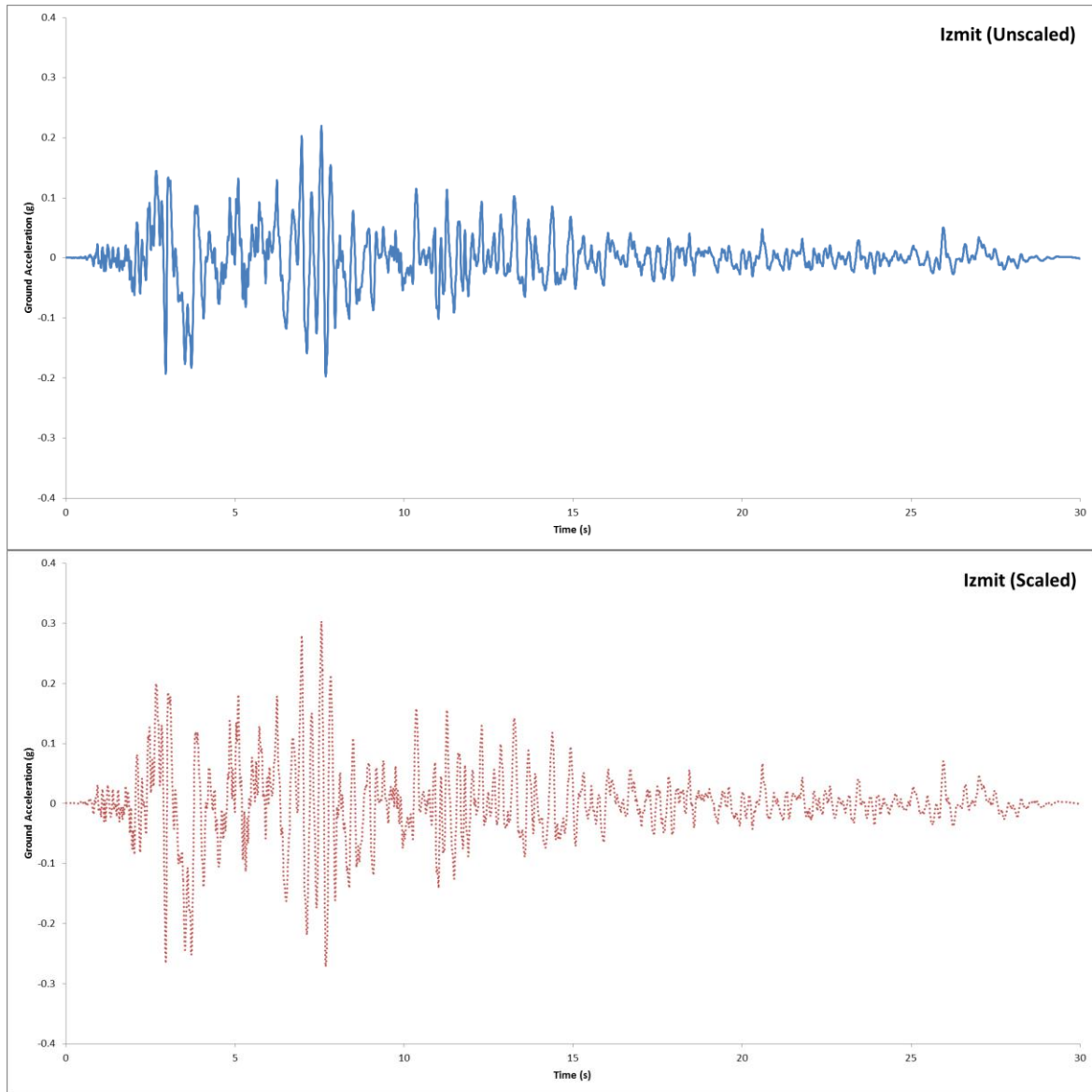

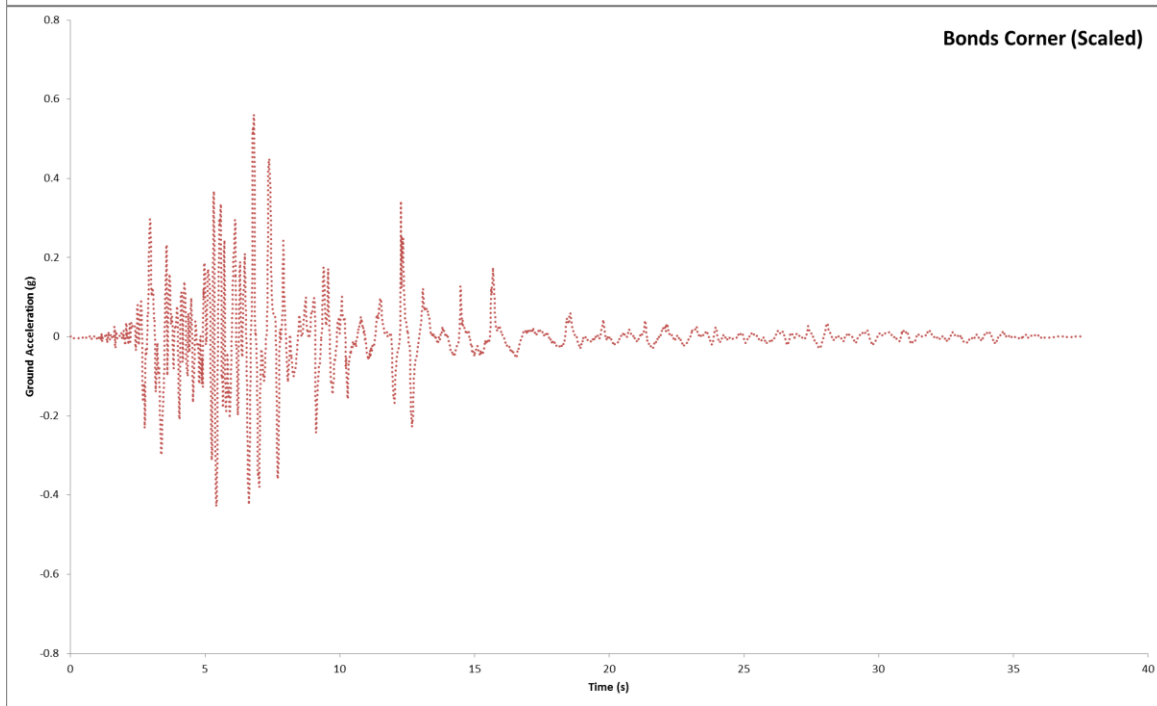
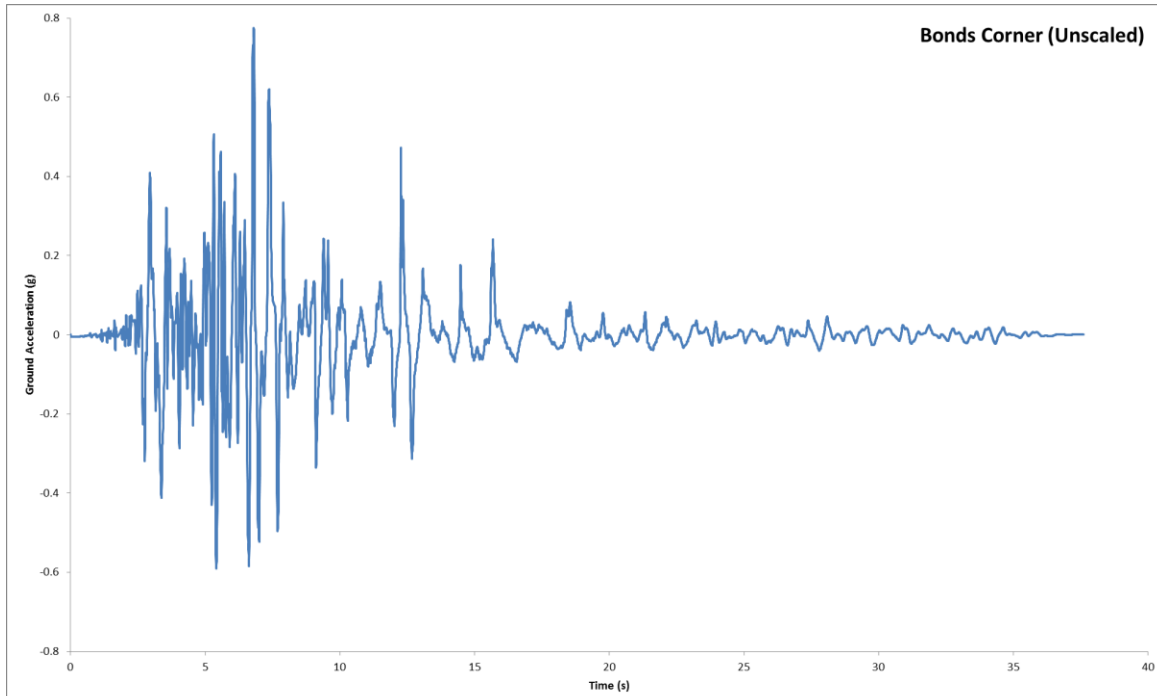

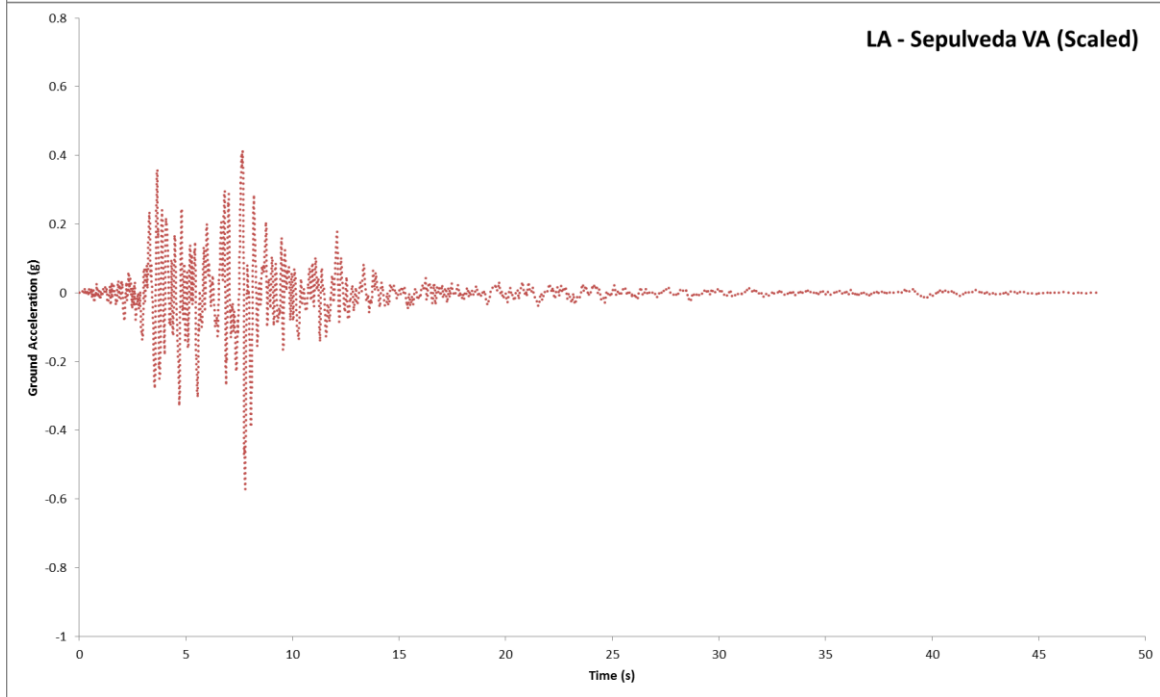
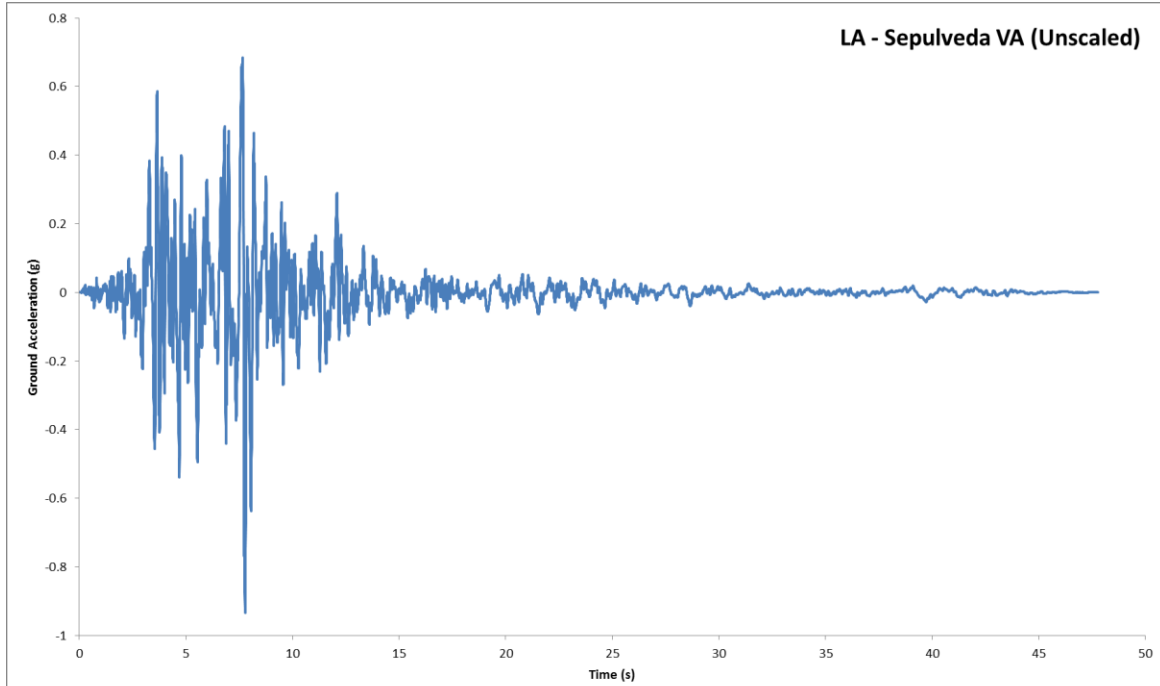

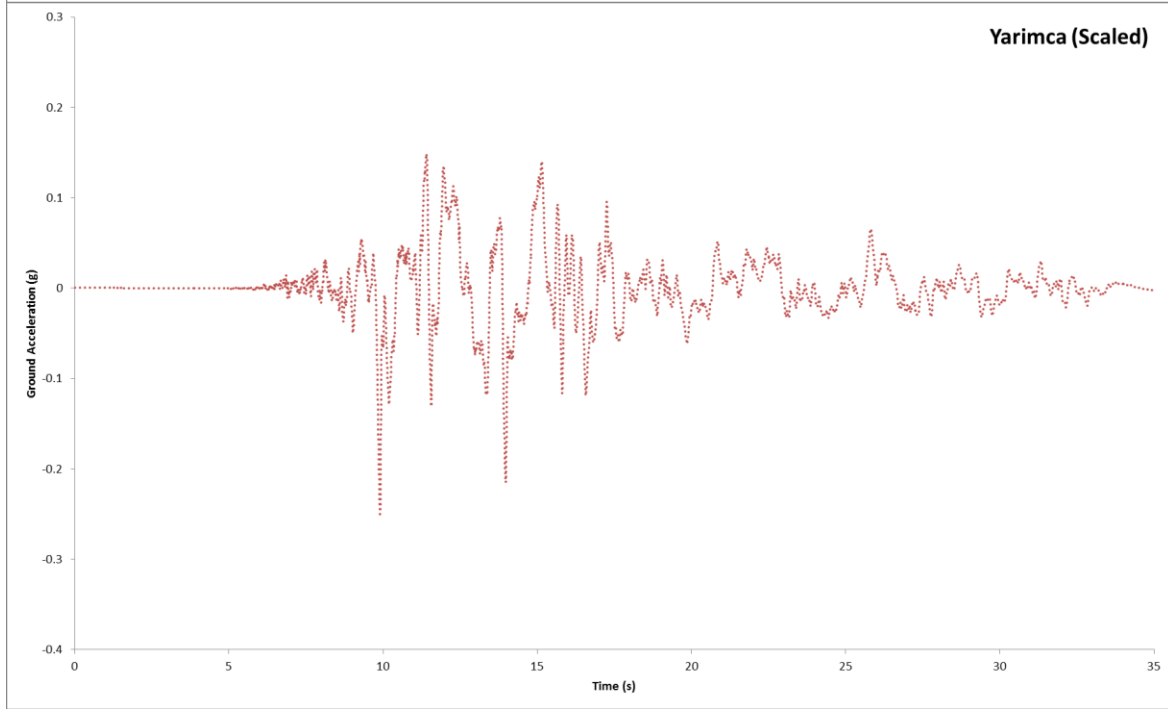
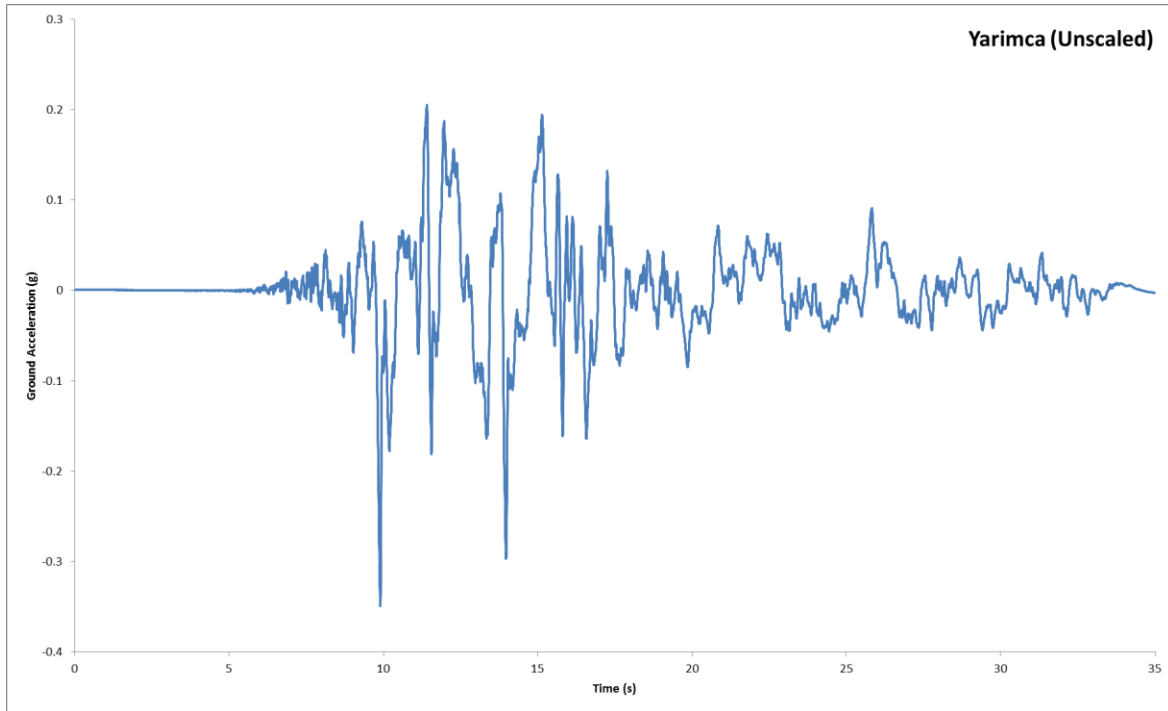

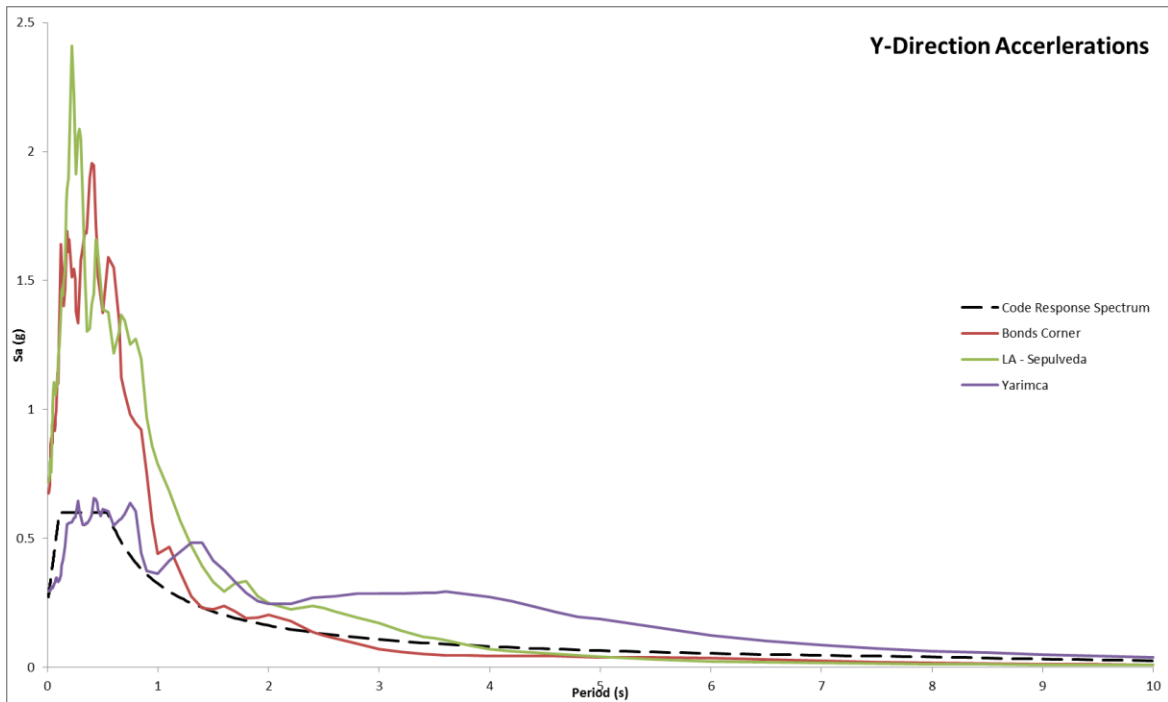
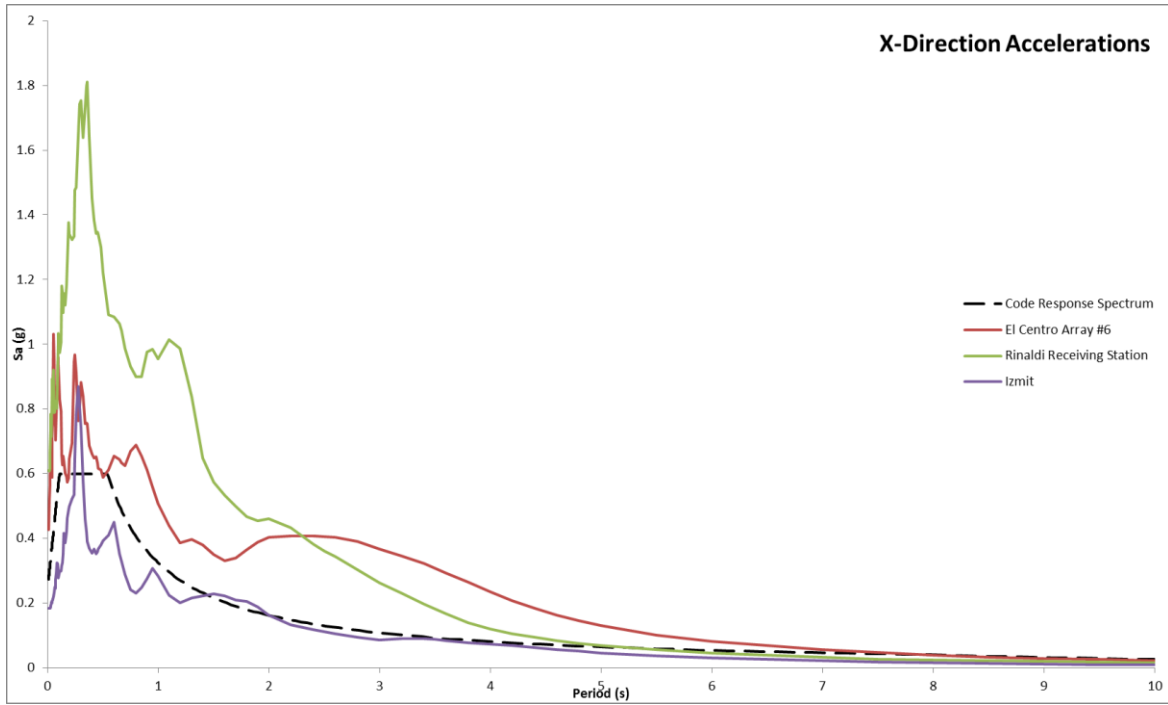

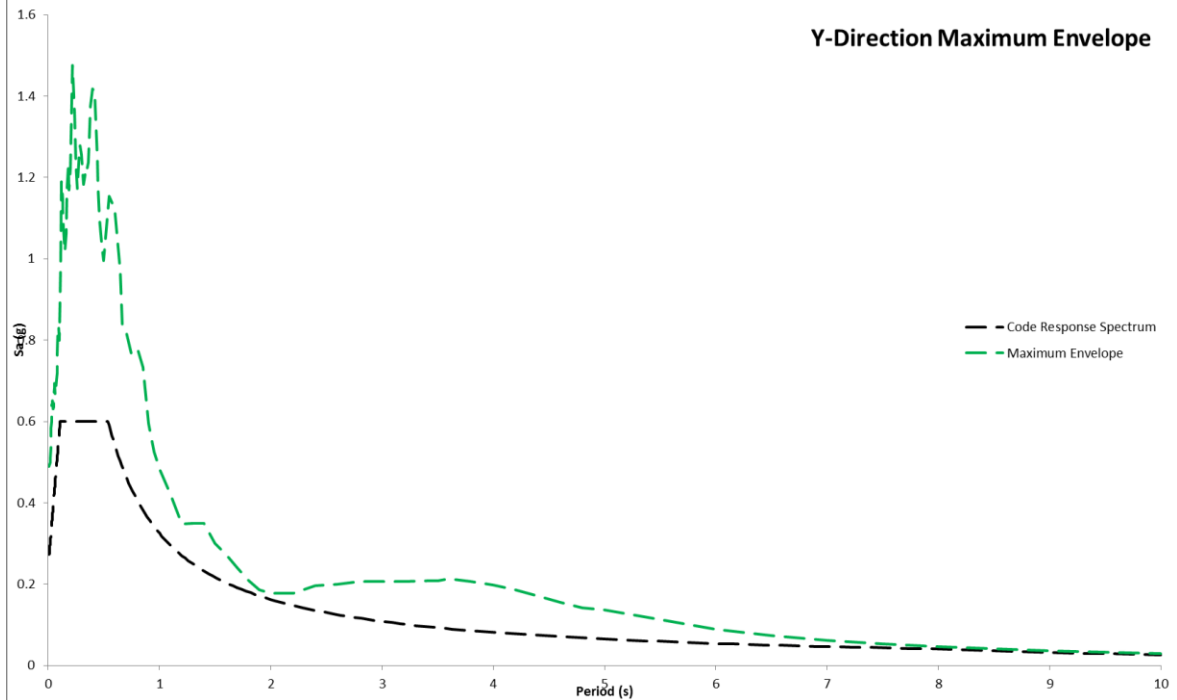
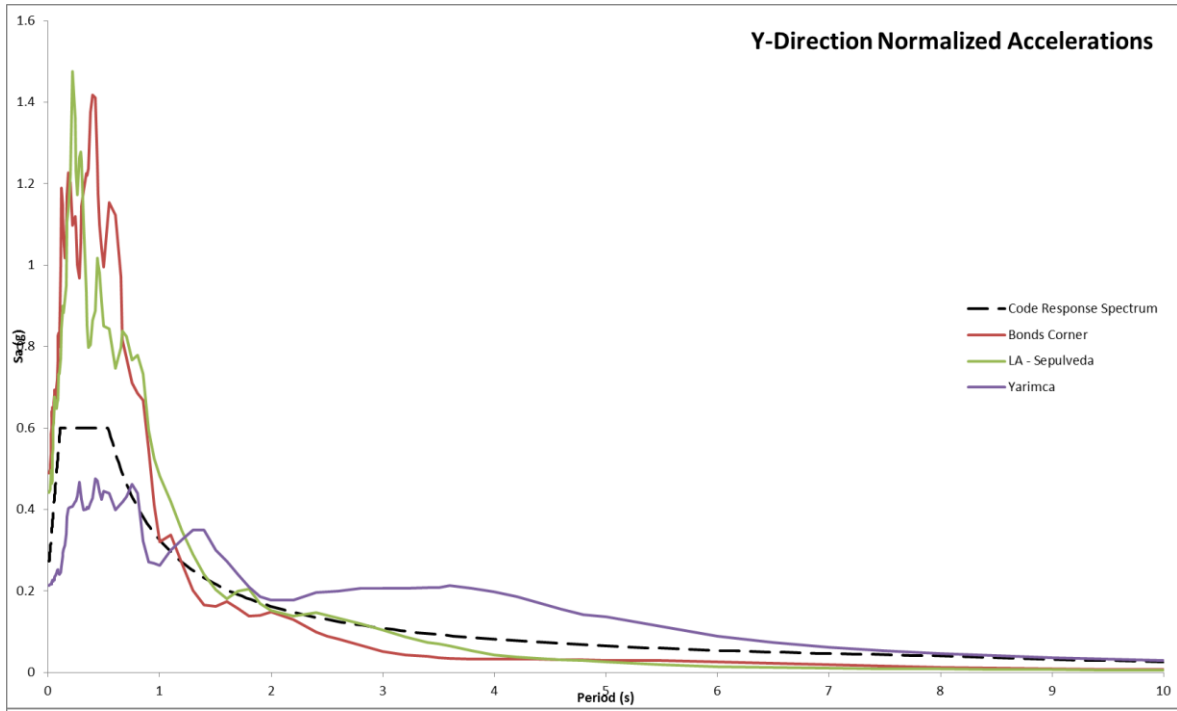

Appendix H: Construction Management Breadth

Existing Structure: Falls Church, VA

Superstructure:				
Description of Work	Original Cost	Alterations		Revised Cost
	Allocation	Change Orders	TRF	Allocation
Concrete:				
C-I-P Southland Concrete Corporation	5,020,000.00	11,243.00	57,031.00	5,088,274.00
OT Beyond Contractors Control	10,140.00			10,140.00
Concrete Housekeeping Pads	5,000.00			5,000.00
Crete-Seal Concrete Sealer	211,000.00			211,000.00
Undercut Unsuitable Soils	1,500.00			1,500.00
Allowance - ASI #1	2,662.00	(2,662.00)		-
Total Original Cost =	5,250,302.00	Revised Cost =		5,315,914.00
% of Total Building Cost =	6.9%	% of Total Building Cost =		7.1%

Building Enclosure/Façade:				
Description of Work	Original Cost	Alterations		Revised Cost
	Allocation	Change Orders	TRF	Allocation
Concrete:				
Arch Precast Concrete - Arban & Carosi	1,340,000.00			1,340,000.00
Stainless Steel Gutter System	80,000.00			80,000.00
Masonry:				
Masonry - United Masonry	312,758.00	612.00	10,482.00	323,852.00
Stone Masonry - Neka	20,000.00		10,500.00	30,500.00
Metals:				
Misc. Metals - American Iron Workers	1,281,837.00	50,287.00	7,595.00	1,339,719.00
Misc. Metals	81,920.00			81,920.00
Expansion Joints - Construction Spec.	25,169.00			25,169.00
Thermal and Moisture Protection:				
Waterproofing - Prospect Waterproofing	178,951.00	52,198.00	83,539.00	314,688.00
Stucco	110,785.00			110,785.00
Roofing - Prospect Waterproofing	534,725.00	(160.00)		534,565.00
Fireproofing - Artic Fireproofing	113,651.00			113,651.00
Firestopping - Z & E Enterprises	240,250.00	2,276.00	632.00	243,158.00
Joint Sealants - Caulking	147,465.00			147,465.00
Doors and Windows:				
Glass and Glazing - Trainor Glass Co.	2,475,000.00	13,435.00	17,505.00	2,505,940.00
OT Beyond Contractors Control	3,000.00			3,000.00
1% Glass Breakage	25,000.00			25,000.00
Allowance - ASI #1	940.00	(940.00)		-
Specialties:				
Wall Protection - Construction Spec.	252,673.00			252,673.00
Louvers - Construction Spec.	117,513.00	(1,925.00)	1,600.00	117,188.00
Window Treatments	65,048.00			65,048.00
Window Washing Equipment	60,274.00		11,576.00	71,850.00
Total Original Cost =	6,971,451.00	Revised Cost =		7,219,412.00
% of Total Building Cost =	9.2%	% of Total Building Cost =		9.6%

Proposed Structure: Falls Church, VA: CA – Base Isolated Model (Only sample floor calculations are shown)

Ground Floor									
Concrete Costs									
Slab (5")	Materials:	\$ 109.00	per cu. yrds	x	393.7	cu. yrds	=	\$	42,915.39
	Labor:	\$ 41.40	per cu. yrds	x	393.7	cu. yrds	=	\$	16,299.97
Beams/ Girder (24"x24")	Materials:	\$ 109.00	per cu. yrds	x	153.1	cu. yrds	=	\$	16,683.06
	Labor:	\$ 35.55	per cu. yrds	x	153.1	cu. yrds	=	\$	5,441.13
Joists (12"x24")	Materials:	\$ 109.00	per cu. yrds	x	169.2	cu. yrds	=	\$	18,439.17
	Labor:	\$ 87.00	per cu. yrds	x	169.2	cu. yrds	=	\$	14,717.50
Columns (34"x34")	Materials:	\$ 202.00	per cu. yrds	x	72.2	cu. yrds	=	\$	14,588.89
	Labor:	\$ 22.75	per cu. yrds	x	72.2	cu. yrds	=	\$	1,643.06
Walls (12")	Materials:	\$ 109.00	per cu. yrds	x	37.5	cu. yrds	=	\$	4,083.26
	Labor:	\$ 29.00	per cu. yrds	x	37.5	cu. yrds	=	\$	1,086.37
Formwork Costs									
Slab (5")	Materials:	\$ 2.92	per sq. ft.	x	25513	sq. ft.	=	\$	74,497.96
	Labor:	\$ 4.12	per sq. ft.	x	25513	sq. ft.	=	\$	105,113.56
Beams/ Girder (24"x24")	Materials:	\$ 0.66	per sq. ft.	x	7178	sq. ft.	=	\$	4,737.15
	Labor:	\$ 5.20	per sq. ft.	x	7178	sq. ft.	=	\$	37,323.00
Joists (12"x24")	Materials:	\$ 0.99	per sq. ft.	x	9135	sq. ft.	=	\$	9,043.65
	Labor:	\$ 5.45	per sq. ft.	x	9135	sq. ft.	=	\$	49,785.75
Columns (34"x34")	Materials:	\$ 0.75	per sq. ft.	x	4260	sq. ft.	=	\$	3,194.91
	Labor:	\$ 2.91	per sq. ft.	x	4260	sq. ft.	=	\$	12,396.25
Walls (12")	Materials:	\$ 0.74	per sq. ft.	x	1966	sq. ft.	=	\$	1,455.12
	Labor:	\$ 4.58	per sq. ft.	x	1966	sq. ft.	=	\$	9,005.99
Mild Steel Reinforcing Costs									
	Materials:	\$ 980.00	per tons	x	67.5	tons	=	\$	66,198.13
	Labor:	\$ 980.00	per tons	x	67.5	tons	=	\$	66,198.13
								Total =	\$ 574,847.38
4 th Floor									
Concrete Costs									
Slab (5")	Materials:	\$ 109.00	per cu. yrds	x	275.2	cu. yrds	=	\$	29,993.92
	Labor:	\$ 41.40	per cu. yrds	x	275.2	cu. yrds	=	\$	11,392.19
Beams/ Girder (24"x24")	Materials:	\$ 109.00	per cu. yrds	x	162.9	cu. yrds	=	\$	17,758.98
	Labor:	\$ 35.55	per cu. yrds	x	162.9	cu. yrds	=	\$	5,792.03
Joists (12"x24")	Materials:	\$ 109.00	per cu. yrds	x	95.9	cu. yrds	=	\$	10,448.86
	Labor:	\$ 87.00	per cu. yrds	x	95.9	cu. yrds	=	\$	8,339.92
Columns (26"x26")	Materials:	\$ 202.00	per cu. yrds	x	53.7	cu. yrds	=	\$	10,840.67
	Labor:	\$ 22.75	per cu. yrds	x	53.7	cu. yrds	=	\$	1,220.92
Walls (12")	Materials:	\$ 109.00	per cu. yrds	x	68.8	cu. yrds	=	\$	7,504.04
	Labor:	\$ 29.00	per cu. yrds	x	68.8	cu. yrds	=	\$	1,996.49
Formwork Costs									
Slab (5")	Materials:	\$ 2.92	per sq. ft.	x	15850	sq. ft.	=	\$	46,282.00
	Labor:	\$ 4.12	per sq. ft.	x	15850	sq. ft.	=	\$	65,302.00
Beams/ Girder (24"x24")	Materials:	\$ 0.66	per sq. ft.	x	4945	sq. ft.	=	\$	3,263.37
	Labor:	\$ 5.20	per sq. ft.	x	4945	sq. ft.	=	\$	25,711.40
Joists (12"x24")	Materials:	\$ 0.99	per sq. ft.	x	5177	sq. ft.	=	\$	5,124.74
	Labor:	\$ 5.45	per sq. ft.	x	5177	sq. ft.	=	\$	28,211.93
Columns (26"x26")	Materials:	\$ 0.86	per sq. ft.	x	3355	sq. ft.	=	\$	2,884.93
	Labor:	\$ 3.04	per sq. ft.	x	3355	sq. ft.	=	\$	10,197.89
Walls (12")	Materials:	\$ 0.74	per sq. ft.	x	1883	sq. ft.	=	\$	1,393.63
	Labor:	\$ 4.58	per sq. ft.	x	1883	sq. ft.	=	\$	8,625.44
Mild Steel Reinforcing Costs									
	Materials:	\$ 980.00	per tons	x	38.7	tons	=	\$	37,948.36
	Labor:	\$ 980.00	per tons	x	38.7	tons	=	\$	37,948.36
								Total =	\$ 378,182.06

Proposed Structure: Falls Church, VA: CA – Fixed Model (Only sample floor calculations are shown)

Ground Floor									
Concrete Costs									
Slab (5")	Materials:	\$ 109.00	per cu. yrds	x	393.7	cu. yrds	=	\$	42,915.39
	Labor:	\$ 41.40	per cu. yrds	x	393.7	cu. yrds	=	\$	16,299.97
Beams/ Girder (24"x36")	Materials:	\$ 109.00	per cu. yrds	x	249.7	cu. yrds	=	\$	27,219.72
	Labor:	\$ 35.55	per cu. yrds	x	249.7	cu. yrds	=	\$	8,877.63
Joists (12"x24")	Materials:	\$ 109.00	per cu. yrds	x	169.2	cu. yrds	=	\$	18,439.17
	Labor:	\$ 87.00	per cu. yrds	x	169.2	cu. yrds	=	\$	14,717.50
Columns (36"x36")	Materials:	\$ 202.00	per cu. yrds	x	90.3	cu. yrds	=	\$	18,236.11
	Labor:	\$ 22.75	per cu. yrds	x	90.3	cu. yrds	=	\$	2,053.82
Walls (16")	Materials:	\$ 109.00	per cu. yrds	x	49.9	cu. yrds	=	\$	5,442.99
	Labor:	\$ 26.40	per cu. yrds	x	49.9	cu. yrds	=	\$	1,318.30
Formwork Costs									
Slab (5")	Materials:	\$ 2.92	per sq. ft.	x	25513	sq. ft.	=	\$	74,497.96
	Labor:	\$ 4.12	per sq. ft.	x	25513	sq. ft.	=	\$	105,113.56
Beams/ Girder (24"x36")	Materials:	\$ 0.66	per sq. ft.	x	8483	sq. ft.	=	\$	5,598.45
	Labor:	\$ 5.20	per sq. ft.	x	8483	sq. ft.	=	\$	44,109.00
Joists (12"x24")	Materials:	\$ 0.99	per sq. ft.	x	9135	sq. ft.	=	\$	9,043.65
	Labor:	\$ 5.45	per sq. ft.	x	9135	sq. ft.	=	\$	49,785.75
Columns (36"x36")	Materials:	\$ 0.75	per sq. ft.	x	6390	sq. ft.	=	\$	4,792.37
	Labor:	\$ 2.91	per sq. ft.	x	6390	sq. ft.	=	\$	18,594.38
Walls (16")	Materials:	\$ 0.74	per sq. ft.	x	1966	sq. ft.	=	\$	1,455.12
	Labor:	\$ 4.58	per sq. ft.	x	1966	sq. ft.	=	\$	9,005.99
Mild Steel Reinforcing Costs									
	Materials:	\$ 980.00	per tons	x	74.3	tons	=	\$	72,817.94
	Labor:	\$ 980.00	per tons	x	74.3	tons	=	\$	72,817.94
								Total =	\$ 623,152.70
4 th Floor									
Concrete Costs									
Slab (5")	Materials:	\$ 109.00	per cu. yrds	x	275.2	cu. yrds	=	\$	29,993.92
	Labor:	\$ 41.40	per cu. yrds	x	275.2	cu. yrds	=	\$	11,392.19
Beams/ Girder (24"x36")	Materials:	\$ 109.00	per cu. yrds	x	265.6	cu. yrds	=	\$	28,947.13
	Labor:	\$ 35.55	per cu. yrds	x	265.6	cu. yrds	=	\$	9,441.01
Joists (12"x24")	Materials:	\$ 109.00	per cu. yrds	x	95.9	cu. yrds	=	\$	10,448.86
	Labor:	\$ 87.00	per cu. yrds	x	95.9	cu. yrds	=	\$	8,339.92
Columns (28"x28")	Materials:	\$ 202.00	per cu. yrds	x	67.1	cu. yrds	=	\$	13,550.83
	Labor:	\$ 22.75	per cu. yrds	x	67.1	cu. yrds	=	\$	1,526.15
Walls (16")	Materials:	\$ 109.00	per cu. yrds	x	68.8	cu. yrds	=	\$	7,504.04
	Labor:	\$ 26.40	per cu. yrds	x	68.8	cu. yrds	=	\$	1,817.49
Formwork Costs									
Slab (5")	Materials:	\$ 2.92	per sq. ft.	x	15850	sq. ft.	=	\$	46,282.00
	Labor:	\$ 4.12	per sq. ft.	x	15850	sq. ft.	=	\$	65,302.00
Beams/ Girder (24"x36")	Materials:	\$ 0.66	per sq. ft.	x	5844	sq. ft.	=	\$	3,856.71
	Labor:	\$ 5.20	per sq. ft.	x	5844	sq. ft.	=	\$	30,386.20
Joists (12"x24")	Materials:	\$ 0.99	per sq. ft.	x	5177	sq. ft.	=	\$	5,124.74
	Labor:	\$ 5.45	per sq. ft.	x	5177	sq. ft.	=	\$	28,211.93
Columns (28"x28")	Materials:	\$ 0.86	per sq. ft.	x	3913	sq. ft.	=	\$	3,365.27
	Labor:	\$ 3.04	per sq. ft.	x	3913	sq. ft.	=	\$	11,895.83
Walls (16")	Materials:	\$ 0.74	per sq. ft.	x	1883	sq. ft.	=	\$	1,393.63
	Labor:	\$ 4.58	per sq. ft.	x	1883	sq. ft.	=	\$	8,625.44
Mild Steel Reinforcing Costs									
	Materials:	\$ 980.00	per tons	x	42.6	tons	=	\$	41,743.20
	Labor:	\$ 980.00	per tons	x	42.6	tons	=	\$	41,743.20
								Total =	\$ 410,891.70

Proposed Structure: Falls Church, VA: CA – Base Isolated Model (Only sample floor calculations are shown)

Schedule Calculations for S-1 Base Isolated Structure					
Ground Floor		Daily Output (units/day)		Quantity	Days Required
Formwork	Slab	500	sq. ft	25513	51.0
	Beam/Girders	395	sq. ft	7178	18.2
	Joists	377	sq. ft	9135	24.2
	Columns	460	sq. ft	4260	9.3
	Walls	450	sq. ft	1966	4.4
	Mild Steel Reinforcing	2.3	tons	68	29.4
Placement	Slab	95	cubic yds	394	4.1
	Beam/Girders	90	cubic yds	153	1.7
	Joists	60	cubic yds	169	2.8
	Columns	140	cubic yds	72	0.5
	Walls	110	cubic yds	37	0.3
4 th Floor		Daily Output (units/day)		Quantity	Days Required
Formwork	Slab	500	sq. ft	15850	31.7
	Beam/Girders	395	sq. ft	4945	12.5
	Joists	377	sq. ft	5177	13.7
	Columns	460	sq. ft	3355	7.3
	Walls	450	sq. ft	1883	4.2
	Mild Steel Reinforcing	2.3	tons	39	16.8
Placement	Slab	95	cubic yds	275	2.9
	Beam/Girders	90	cubic yds	163	1.8
	Joists	60	cubic yds	96	1.6
	Columns	140	cubic yds	54	0.4
	Walls	110	cubic yds	69	0.6
Penthouse/Roof		Daily Output (units/day)		Quantity	Days Required
Formwork	Slab	500	sq. ft	15850	31.7
	Beam/Girders	395	sq. ft	4945	12.5
	Joists	377	sq. ft	5177	13.7
	Columns	460	sq. ft	4637	10.1
	Walls	450	sq. ft	2603	5.8
	Mild Steel Reinforcing	2.3	tons	39	17.1
Placement	Slab	95	cubic yds	275	2.9
	Beam/Girders	90	cubic yds	163	1.8
	Joists	60	cubic yds	96	1.6
	Columns	92	cubic yds	36	0.4
	Walls	110	cubic yds	47	0.4

Proposed Structure: Falls Church, VA: CA – Fixed Model (Only sample floor calculations are shown)

Schedule Calculations for S-1 Fixed Base Structure					
Ground Floor		Daily Output (units/day)		Quantity	Days Required
Formwork	Slab	500	sq. ft	25513	51.0
	Beam/Girders	395	sq. ft	8483	21.5
	Joists	377	sq. ft	9135	24.2
	Columns	460	sq. ft	6390	13.9
	Walls	450	sq. ft	1966	4.4
	Mild Steel Reinforcing	2.3	tons	74	32.3
Placement	Slab	95	cubic yds	394	4.1
	Beam/Girders	90	cubic yds	250	2.8
	Joists	60	cubic yds	169	2.8
	Columns	140	cubic yds	90	0.6
	Walls	120	cubic yds	50	0.4
4 th Floor		Daily Output (units/day)		Quantity	Days Required
Formwork	Slab	500	sq. ft	15850	31.7
	Beam/Girders	395	sq. ft	5844	14.8
	Joists	377	sq. ft	5177	13.7
	Columns	440	sq. ft	3913	8.9
	Walls	450	sq. ft	1883	4.2
	Mild Steel Reinforcing	2.3	tons	43	18.5
Placement	Slab	95	cubic yds	275	2.9
	Beam/Girders	90	cubic yds	266	3.0
	Joists	60	cubic yds	96	1.6
	Columns	140	cubic yds	67	0.5
	Walls	120	cubic yds	69	0.6
Penthouse/Roof		Daily Output (units/day)		Quantity	Days Required
Formwork	Slab	500	sq. ft	15850	31.7
	Beam/Girders	395	sq. ft	5844	14.8
	Joists	377	sq. ft	5177	13.7
	Columns	440	sq. ft	5410	12.3
	Walls	450	sq. ft	2603	5.8
	Mild Steel Reinforcing	2.3	tons	43	18.8
Placement	Slab	95	cubic yds	275	2.9
	Beam/Girders	90	cubic yds	266	3.0
	Joists	60	cubic yds	96	1.6
	Columns	92	cubic yds	45	0.5
	Walls	120	cubic yds	47	0.4

Existing Structure: Falls Church, VA: CA – Base Model

	Task Mode	Task Name	Duration	Start	Finish	Qtr 4, 2010	Qtr 1, 2011	Qtr 2, 2011	Qtr 3, 2011	Qtr 4, 2011	Qtr 1, 2012	Qtr 2, 2012
						Oct	Nov	Dec	Jan	Feb	Mar	Apr
1		+ Earthwork and Foundations	179 days	Wed 10/20/10	Mon 6/27/11							
5		+ Basement Level	167 days	Fri 11/5/10	Mon 6/27/11							
44		+ Col. Lines A to D	118 days	Thu 1/13/11	Mon 6/27/11							
72		+ Col. Lines D to H	93 days	Wed 1/26/11	Fri 6/3/11							
93		+ Ground Level	71 days	Thu 1/13/11	Thu 4/21/11							
104		+ Tunnel	145 days	Mon 11/15/10	Fri 6/3/11							
126		+ Structure	270 days	Tue 3/29/11	Mon 4/9/12							
440		+ Façade and Roof	214 days	Mon 6/20/11	Thu 4/12/12							

Proposed Structure: Falls Church, VA: CA – Fixed Model

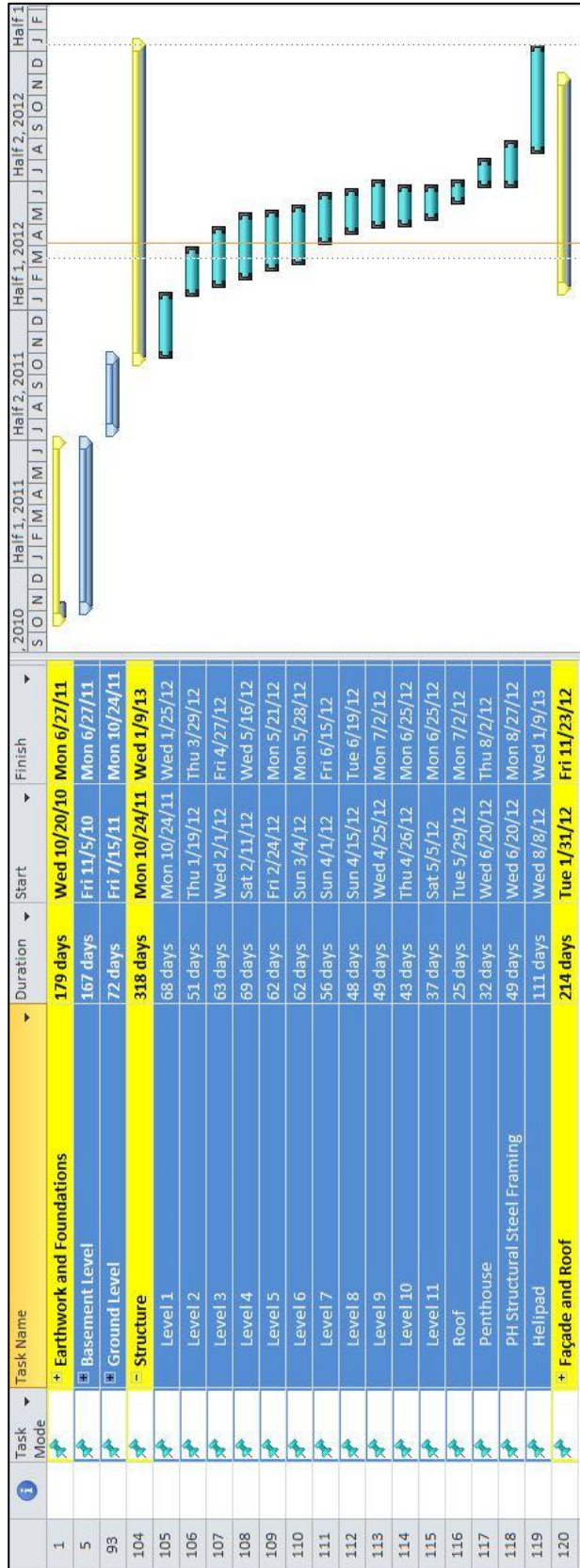

Proposed Structure: Falls Church, VA: CA – Base Isolation Model

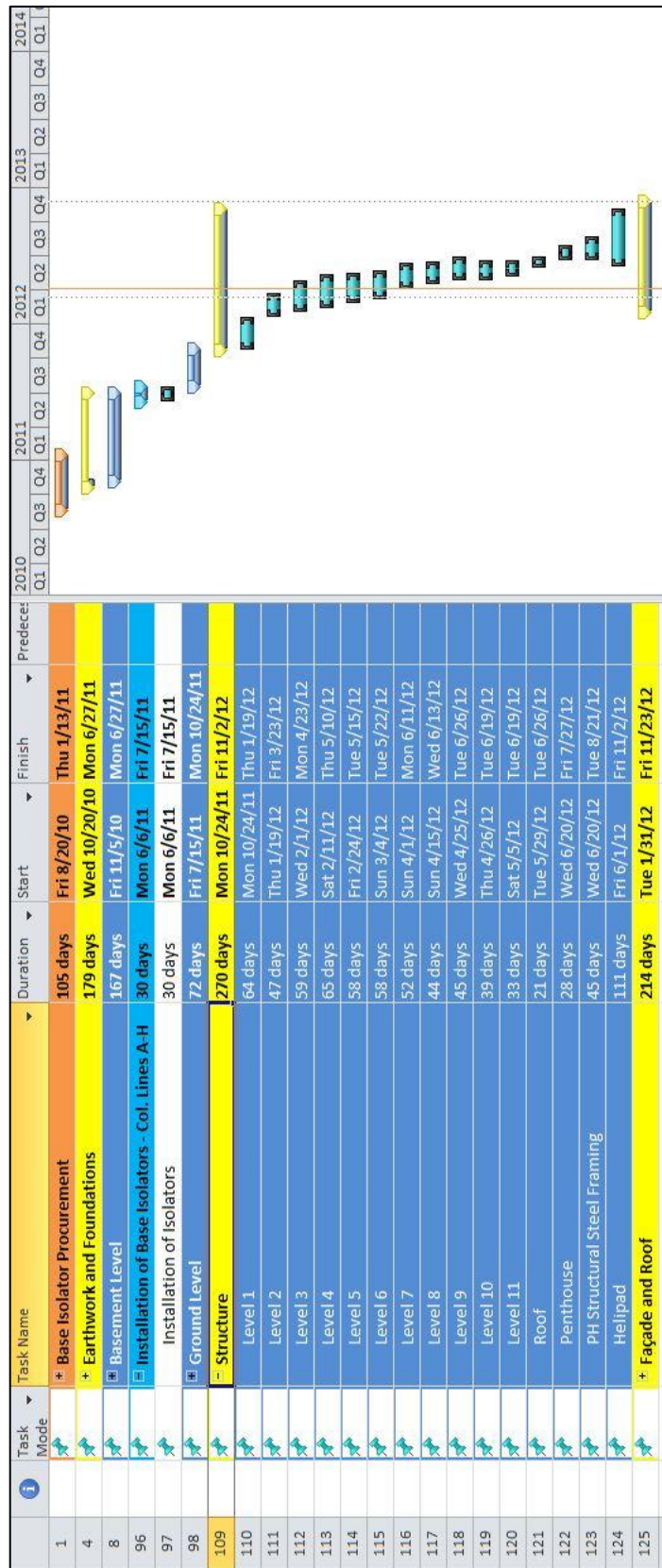

Appendix I: Mechanical/Building Enclosure Breadth

Existing Glazing: Sacramento, California

Room Checksums
By ACADEMIC

11 Patient Room 11												
COOLING COIL PEAK			CLG SPACE PEAK			HEATING COIL PEAK			TEMPERATURES			
Peaked at Time: Outside Air: Mo/Hr: 8 / 14 OADBWB/Hr: 96 / 69 / 66			Mo/Hr: 10 / 15 OADB: 86			Mo/Hr: Heating Design OADB: 32			SADB			
Space Sens. + Lat. Sens. + Lat. Plenum Total	Space Sensible OF Total (%)	Net Total OF Total (%)	Space Sensible OF Total (%)	Space Sensible OF Total (%)	Space Sensible OF Total (%)	Space Sensible OF Total (%)	Space Sensible OF Total (%)	Space Sensible OF Total (%)	Space Sensible OF Total (%)	Space Sensible OF Total (%)	Space Sensible OF Total (%)	Space Sensible OF Total (%)
Btu/h	Btu/h	Btu/h	Btu/h	Btu/h	Btu/h	Btu/h	Btu/h	Btu/h	Btu/h	Btu/h	Btu/h	Btu/h
Envelope Loads												
Sky/lite Solar	0	0	0	0	0	0	0	0	0	0	0	0
Sky/lite Cond	0	0	0	0	0	0	0	0	0	0	0	0
Roof Cond	0	0	0	0	0	0	0	0	0	0	0	0
Glass Solar	1,992	1,992	15	3,455	55	1,992	15	3,455	55	1,992	15	3,455
Glass/Door Cond	248	248	2	142	2	248	2	142	2	248	2	142
Wall Cond	127	127	2	178	3	127	2	178	3	127	2	178
Partition/Door	0	0	0	0	0	0	0	0	0	0	0	0
Floor	0	0	0	0	0	0	0	0	0	0	0	0
Adjacent Floor	0	0	0	0	0	0	0	0	0	0	0	0
Infiltration	186	186	1	90	1	186	1	90	1	186	1	90
Sub Total ==>	2,554	190	2,744	3,865	62	2,554	20	3,865	62	2,554	20	3,865
Internal Loads												
Lights	241	60	301	222	4	241	2	222	4	241	2	222
People	1,080	0	1,080	600	10	1,080	8	600	10	1,080	8	600
Misc	1,466	0	1,466	1,466	23	1,466	11	1,466	23	1,466	11	1,466
Sub Total ==>	2,787	60	2,847	2,289	37	2,787	21	2,289	37	2,787	21	2,289
Ceiling Load	102	-102	0	87	1	102	0	87	1	102	0	87
Ventilation Load	0	0	0	0	0	0	0	0	0	0	0	0
Adj Air Trans Heat	0	0	4,034	0	0	0	0	0	0	0	0	0
Dehumid. Ov Sizing	0	0	0	0	0	0	0	0	0	0	0	0
Ov/Undr Sizing	1,940	-481	1,940	0	0	1,940	14	0	0	1,940	14	0
Exhaust Heat	-481	-481	0	0	0	-481	-4	0	0	-481	-4	0
Sup. Fan Heat	926	926	0	926	7	926	7	926	7	926	7	926
Duct Heat PkUp	0	0	0	0	0	0	0	0	0	0	0	0
Underfir Sup Ht PkUp	0	0	0	0	0	0	0	0	0	0	0	0
Supply Air Leakage	0	0	0	0	0	0	0	0	0	0	0	0
Grand Total ==>	7,382	594	13,518	6,241	100.00	7,382	100.00	6,241	100.00	7,382	100.00	6,241
Envelope Loads												
Sky/lite Solar	0	0	0	0	0	0	0	0	0	0	0	0
Sky/lite Cond	0	0	0	0	0	0	0	0	0	0	0	0
Roof Cond	0	0	0	0	0	0	0	0	0	0	0	0
Glass Solar	1,992	1,992	15	3,455	55	1,992	15	3,455	55	1,992	15	3,455
Glass/Door Cond	248	248	2	142	2	248	2	142	2	248	2	142
Wall Cond	127	127	2	178	3	127	2	178	3	127	2	178
Partition/Door	0	0	0	0	0	0	0	0	0	0	0	0
Floor	0	0	0	0	0	0	0	0	0	0	0	0
Adjacent Floor	0	0	0	0	0	0	0	0	0	0	0	0
Infiltration	186	186	1	90	1	186	1	90	1	186	1	90
Sub Total ==>	2,554	190	2,744	3,865	62	2,554	20	3,865	62	2,554	20	3,865
Internal Loads												
Lights	241	60	301	222	4	241	2	222	4	241	2	222
People	1,080	0	1,080	600	10	1,080	8	600	10	1,080	8	600
Misc	1,466	0	1,466	1,466	23	1,466	11	1,466	23	1,466	11	1,466
Sub Total ==>	2,787	60	2,847	2,289	37	2,787	21	2,289	37	2,787	21	2,289
Ceiling Load	102	-102	0	87	1	102	0	87	1	102	0	87
Ventilation Load	0	0	0	0	0	0	0	0	0	0	0	0
Adj Air Trans Heat	0	0	4,034	0	0	0	0	0	0	0	0	0
Dehumid. Ov Sizing	0	0	0	0	0	0	0	0	0	0	0	0
Ov/Undr Sizing	1,940	-481	1,940	0	0	1,940	14	0	0	1,940	14	0
Exhaust Heat	-481	-481	0	0	0	-481	-4	0	0	-481	-4	0
Sup. Fan Heat	926	926	0	926	7	926	7	926	7	926	7	926
Duct Heat PkUp	0	0	0	0	0	0	0	0	0	0	0	0
Underfir Sup Ht PkUp	0	0	0	0	0	0	0	0	0	0	0	0
Supply Air Leakage	0	0	0	0	0	0	0	0	0	0	0	0
Grand Total ==>	7,382	594	13,518	6,241	100.00	7,382	100.00	6,241	100.00	7,382	100.00	6,241

COOLING COIL SELECTION		HEATING COIL SELECTION	
Total Capacity ton	Sens Cap. MBh	Capacity MBh	Coil Airflow cfm
Main Clg	1.1	12.4	254
Aux Clg	0.0	0.0	0
Opt Vent	0.0	0.0	0
Total	1.1	13.5	254

AREAS		HEATING COIL SELECTION	
Gross Total ft²	Glass ft² (%)	Capacity MBh	Coil Airflow cfm
Floor	217	-8.8	254
Part	0	0.0	0
Int Door	0	0.0	0
ExFlr	0	0.0	0
Roof	217	-9.7	260
Wall	173	50	29
Ext Door	0	0	0
Total	607	-18.5	543

TEMPERATURES		AIRFLOWS	
Cooling °F	Heating °F	Cooling	Heating
50.0	75.6	254	254
73.6	71.0	260	260
75.2	72.0	135	135
85.6	51.7	0	0
0.5	0.0	0	0
1.2	0.0	0	0
3.6	0.0	0	0

ENGINEERING CKS	
Cooling	Heating
% OA	50.8
cfm/ft²	50.8
cfm/ton	1.17
ft²/ton	225.90
Btu/hr-ft²	192.64
No. People	62.29
	-85.33

RACE@ 700 v6.2.6.5 calculated at 09:13 AM on 04/04/2012
Iterative - 1 System Checksums Report Page 43 of 228

Project Name: Existing System
Dataset Name: Existing System

Alternate Glazing: Sacramento, California

Room Checksums
By ACADEMIC

11 Patient Room 11

COOLING COIL PEAK		CLG SPACE PEAK		HEATING COIL PEAK		TEMPERATURES	
Peaked at Time: Outside Air: Mo/Hr: 8 / 14 OADBWB/Hr: 96 / 69 / 66		Mo/Hr: 10 / 15 OADB: 86		Mo/Hr: Heating Design OADB: 32		SADB Ra Plenum Return Ret/OA Fm MtrTD Fm BlgTD Fm Frict	
Space Sens. + Lat. Sens. + Lat. Plenum Sens. + Lat. Total	Space Sensible OF Total (%)	Space Sensible OF Total (%)	Net Total (%)	Space Sensible OF Total (%)	Space Peak Btu/h	Coil Peak Btu/h	Coil Peak Percent OF Total (%)
Envelope Loads	0	0	0	0	0	0	0
SkyLite Solar	0	0	0	0	0	0	0
SkyLite Cond	0	0	0	0	0	0	0
Roof Cond	68	68	0	0	0	0	0
Glass Solar	1,548	1,548	13	49	2,685	-203	2,64
Glass/Door Cond	206	0	206	2	118	-483	6,28
Wall Cond	127	0	249	3	178	-208	2,70
Partition/Door	0	0	0	0	0	-106	0
Floor	0	0	0	0	0	0	0
Adjacent Floor	0	0	0	0	0	0	0
Infiltration	186	0	186	2	90	-266	3,46
Sub Total ==>	2,068	190	2,258	18	3,071	-1,160	15,08
Internal Loads							
Lights	241	60	301	2	222	0	0,00
People	1,080	0	1,080	9	800	0	0,00
Misc	1,466	0	1,466	12	1,466	0	0,00
Sub Total ==>	2,787	60	2,847	23	2,289	0	0,00
Ceiling Load	102	-102	0	0	87	-72	0,00
Ventilation Load	0	0	4,035	33	0	0	74,95
Adj Air Trans Heat	0	0	0	0	0	0	0
Dehumid. Ov Sizing	1,492	0	0	0	0	0	0,00
Ov/Undr Sizing	-481	0	1,492	12	0	0	0,00
Exhaust Heat	811	0	-481	-4	0	0	0,00
Sup. Fan Heat	0	0	1,316	11	0	0	0,00
Duct Heat PkUp	0	0	811	7	0	0	0,00
Underfir Sup Ht PkUp	0	0	0	0	0	0	0,00
Supply Air Leakage	0	0	0	0	0	0	0,00
Grand Total ==>	6,449	478	12,278	100,00	5,446	-927	100,00

COOLING COIL SELECTION		HEATING COIL SELECTION	
Total Capacity ton	Sens Cap. M/Bh	Capacity M/Bh	Coil Airflow cfm
Main Clg	1.0	11.1	222
Aux Clg	0.0	0.0	0
Opt Vent	0.0	0.0	0
Total	1.0	12.3	222

AREAS		HEATING COIL SELECTION	
Gross Total ft²	Glass ft² (%)	Capacity M/Bh	Coil Airflow cfm
Floor	217	-7.7	222
Part	0	0.0	0
Int Door	0	0.0	0
Ext Door	0	0.0	0
Roof	217	0.0	0
Wall	173	-8.5	228
Ext Door	0	0.0	0
Total	607	-16.2	586

AIRFLOWS		TEMPERATURES	
Diffuser	Return	Cooling	Heating
222	222	50.0	75.7
222	222	73.5	71.0
222	222	87.1	72.0
135	135	0.5	48.7
0	0	1.2	0.0
0	0	3.6	0.0

ENGINEERING CKS	
% OA	No. People
58.2	3
1.02	
217.06	
212.09	
56.58	
-74.74	

Project Name: Alternative System.trc
 Dataset Name: Alternative System.trc
 RACE® 700 v6.2.6.5 calculated at 09:01 AM on 04/04/2012
 Iterative - 1 System Checksums Report Page 43 of 228

Alternate Glazing Cut Sheet: Sacramento, California (Courtesy of Oldcastle)

ARCHITECTURAL GUIDE SPECIFICATION
SECTION 08 81 00 GLASS GLAZING

Note to Specifiers:

The specifications below are suggested as desirable inclusions in glass and glazing specifications (section 08 81 00), but are not intended to be complete. An appropriate and qualified Architect or Engineer must verify suitability of a particular product for use in a particular application as well as review final specifications. Oldcastle BuildingEnvelope™ assumes no responsibility or liability for the information included or not included in these specifications.

PRODUCTS

Approved Glass Fabricator	Oldcastle BuildingEnvelope™
Glass Description	FLOAT GLASS
	<ol style="list-style-type: none"> USA - Annealed float glass shall comply with ASTM C1036, Type I, Class 1 (clear), Class 2 (tinted), Quality-Q3. Canada - Annealed float glass shall comply with CAN/CGSB-12.3-M, Quality-Glazing. USA- Heat-strengthened float glass shall comply with ASTM C1048, Type I, Class 1 (clear), Class 2 (tinted), Quality Q3, Kind HS. Canada - Heat-strengthened float glass shall comply with CAN/CGSB-12.9-M, Type 2-Heat-Strengthened Glass, Class A-Float Glass. USA - Tempered float glass shall comply with ASTM C1048, Type I, Class 1 (clear), Class 2 (tinted), Quality Q3, Kind FT. Canada - Tempered float glass shall comply with CAN/CGSB-12.1-M, Type 2-Tempered Glass, Class B-Float Glass. USA - Laminated glass to comply with ASTM C1172. Canada - Laminated glass to comply with CAN/CGSB-12.1-M, Type 1-Laminated Glass, Class B-Float Glass. Glass shall be annealed, heat-strengthened or tempered as required by codes, or as required to meet thermal stress and wind loads.



Sealed Insulating Glass (IG) Vision Glass (Vertical)	GENERAL
	<ol style="list-style-type: none"> IG units consist of glass lites separated by a dehydrated airspace that is hermetically dual sealed with a primary seal of polyisobutylene (PIB), or thermo plastic spacer (TPS) and a secondary seal of silicone or an organic sealant depending on the application. USA - Insulating glass units are certified through the Insulating Glass Certification Council (IGCC) to ASTM E2190. Canada - Insulating Glass units are certified through the Insulating Glass Manufacturers Alliance (IGMA) to either the IGMAC certification program to CAN/CGSB-12.8, or through the IGMA program to ASTM E2190.

IG VISION UNIT PERFORMANCE CHARACTERISTICS

1. Exterior Lite			
1/4" Oldcastle BuildingEnvelope™ SunGlass® Low-E #2			
2. Interior Lite			
1/4" Clear			
3. 1/2" Cavity			
1/2 inch (90% Argon Fill)			
4. Performance Characteristics			
Thermal		Optical	
Winter U-factor/U-value:	0.24	Visible Light Transmittance:	50%
Summer U-factor/U-value:	0.21	Visible Light Reflectance (outside):	8%
Solar Heat Gain Coefficient:	0.24	Visible Light Reflectance (inside):	11%
Shading Coefficient:	0.28	Total Solar Transmittance:	20%
Relative Heat Gain (Btu/hr-ft²):	58	Total Solar Reflectance (outside):	28%
Light to Solar Gain:	2.08	Ultraviolet Transmittance:	4%

Contact Oldcastle BuildingEnvelope™ at 866-Oldcastle (653-2278) for samples or additional information concerning performance, strength, deflection, thermal stress or application guidelines. GlasSelect® calculates center of glass performance data using the Lawrence Berkeley National Laboratory (LBNL) Window 5.2 program (version 5.2.17) with Environmental Conditions set at NFRC 100-2001. Gas Library ID#1 (Air) is used for Insulating Glass units with air. Gas Library ID#9 (10% Air/90% Argon) is used for Insulating Glass units with argon. Monolithic glass data is from the following sources: 1. LBNL International Glazing Database (IGDB) version 18.1; 2. Vendor supplied spectral data files. Laminated glass data is from the following sources: 1. LBNL International Glazing Database (IGDB) version 18.1; 2. LBNL Optics 5 (version 5.1 Maintenance Pack 2); 3. Vendor supplied spectral data files; 4. Vendor supplied data. Thermal values are in Imperial units.